

PT4900-TM-V2



19 in. High Bright Teleprompter w/ Talent Monitor Kit



OVERVIEW

ikan's professional teleprompter series is designed for a quick and easy setup to work efficiently in studio or broadcast applications. The teleprompter includes a 65/35 reflective glass that makes the reflection easier to see for the presenter. The lightweight aluminum teleprompter has multiple 1/4-20" and 3/8-16" threads for mounting to a tripod or pedestal. The monitor includes HDMI, Composite, and VGA video inputs. Its high bright screen ensures clear visibility in any lighting condition. An intuitive image flip button allows for easy adjustment of the display orientation. This teleprompter kit also features a 19" widescreen SDI talent monitor with a built-in tally light.



What's Included

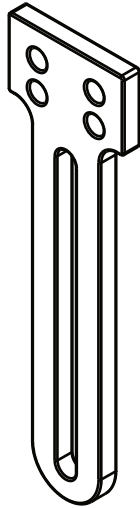

Height Adjustment
Plate

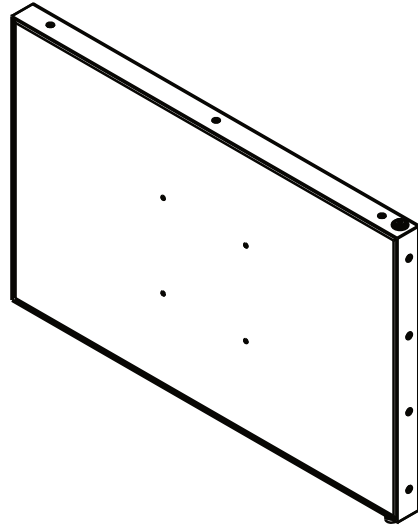

Talent Monitor

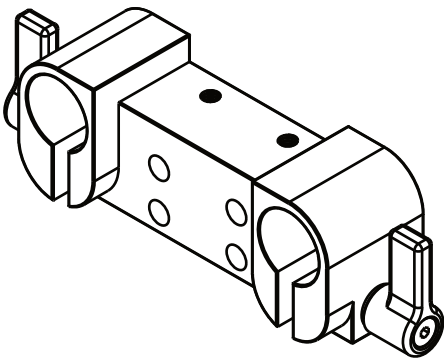

Rod Adapter

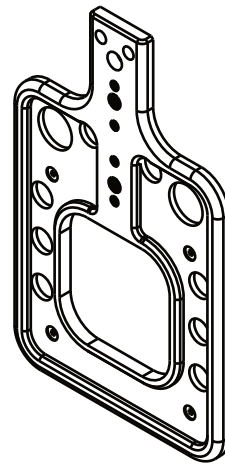

VESA Adapter

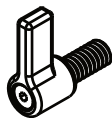

Thumb
Screws



Screws

What's Included

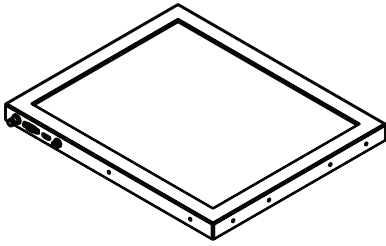

Monitor

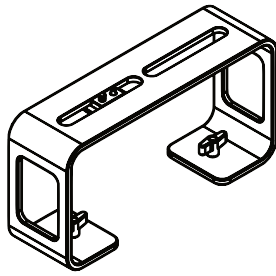

Tall Riser

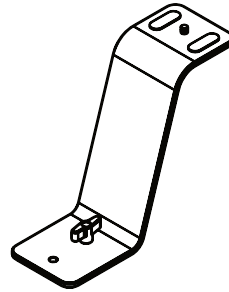

DSLR/Mirrorless Riser

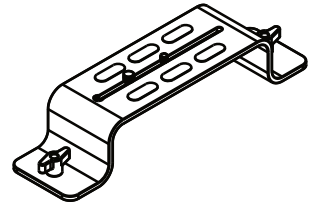

Short Riser

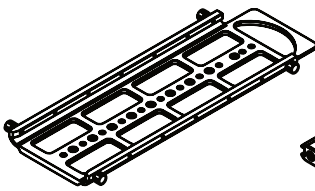

Sled

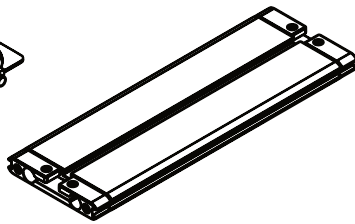

Base

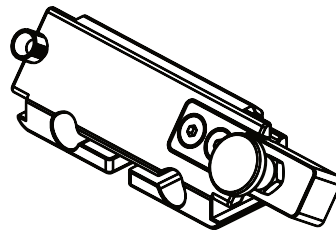

Glass Frame Holder Bracket
w/ Rod Clamps

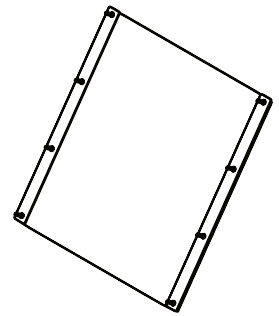

Glass

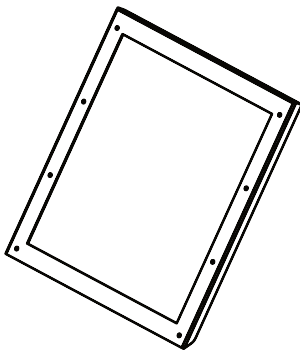

Hood Attachment Frame

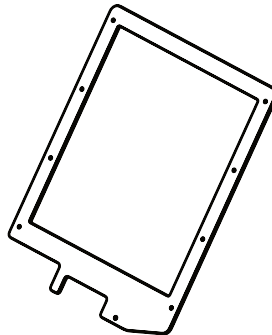

Glass Holder

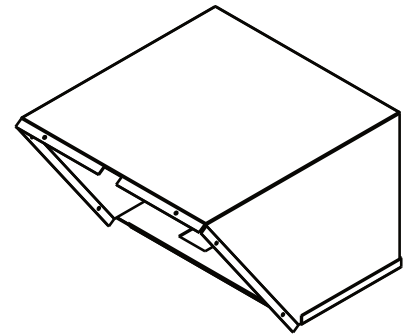

Hood

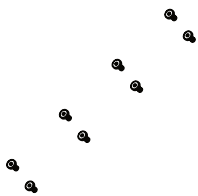

Glass Frame Screws

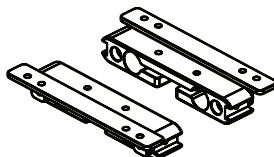

15mm Rod Clamps

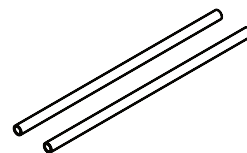

15mm Rods

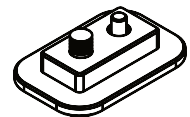

Large Riser
Bracket

Teleprompter Assembly Setup

Step 1

Place the Hood Attachment Frame over the Glass Holder. Then place the glass against the Glass Holder. Make sure the screws pass through the holes on the both the Hood Attachment Frame and the Glass Holder.

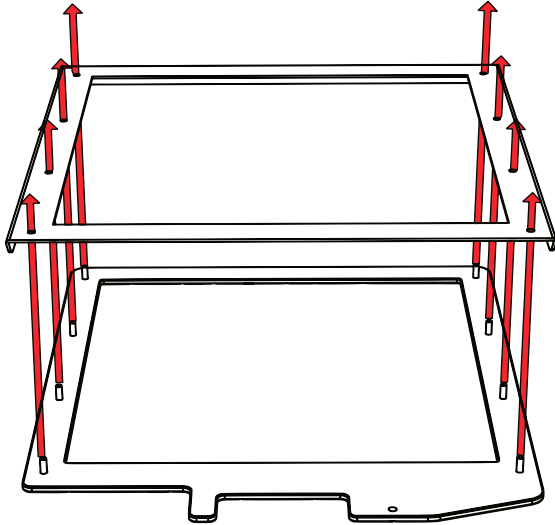

Step 2

Secure the Glass Holder by fastening the knurled nuts to the screws as pictured below.

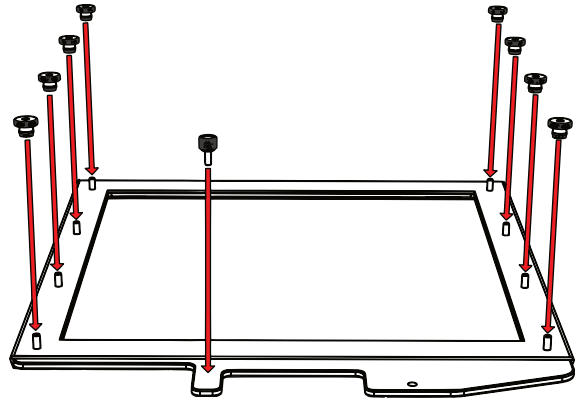

Step 3

Remove the monitor mounts from the teleprompter base using the included larger 4mm hex key to loosen from the 15mm rods.

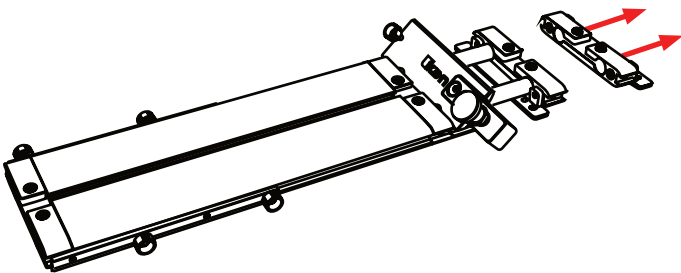

Step 4

Put the washers on before tightening the screws. The washers and 4 additional screws are inside a bag on the bottom foam.

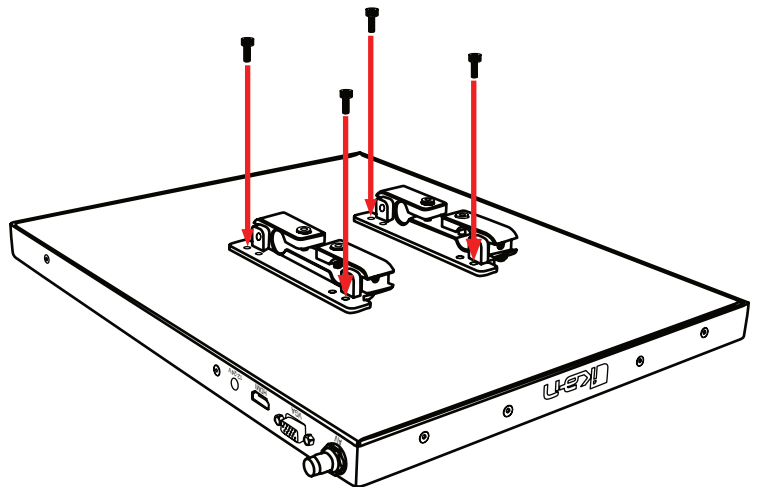

Step 5

After the monitor mounts are attached, adjust the 15mm rods to accommodate the monitor. Leave about 1 inch of room for the teleprompter bracket. Make sure the 15mm rods go through both set of monitor mounts. Please ensure that all screws are properly tightened after inserting the monitor.

SAFETY NOTE Make sure to leave at least 2 inches of the rods inside the teleprompter base.

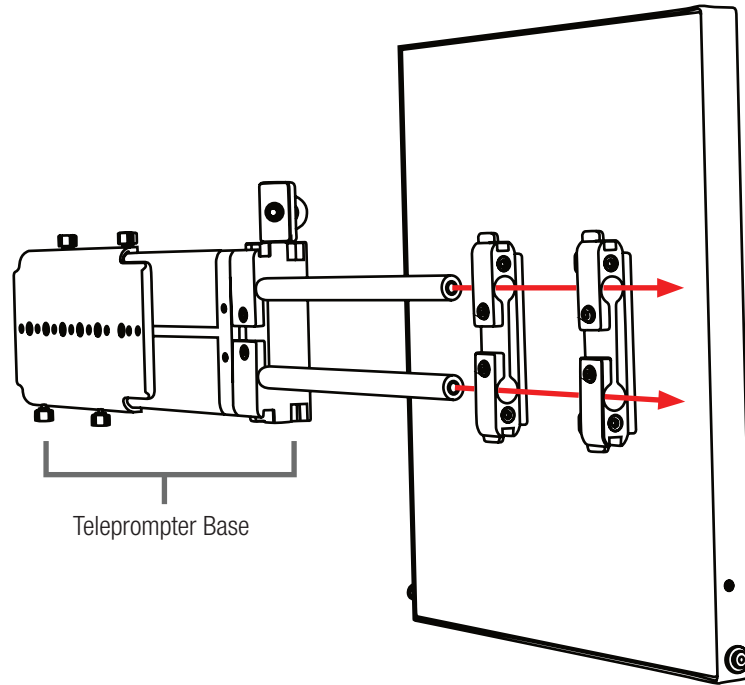

Step 6

While sliding the teleprompter bracket into the slot of the Glass Frame Holder Bracket, pull on the red knob to allow the bracket to fully slide in.

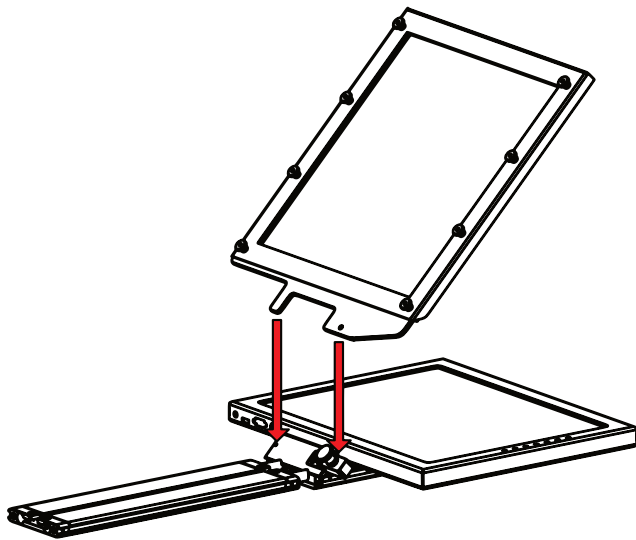

Step 7

Once the bracket is in place, tighten the side screw to lock in place. Double check and make sure all the screws are tightened with the included hex keys.

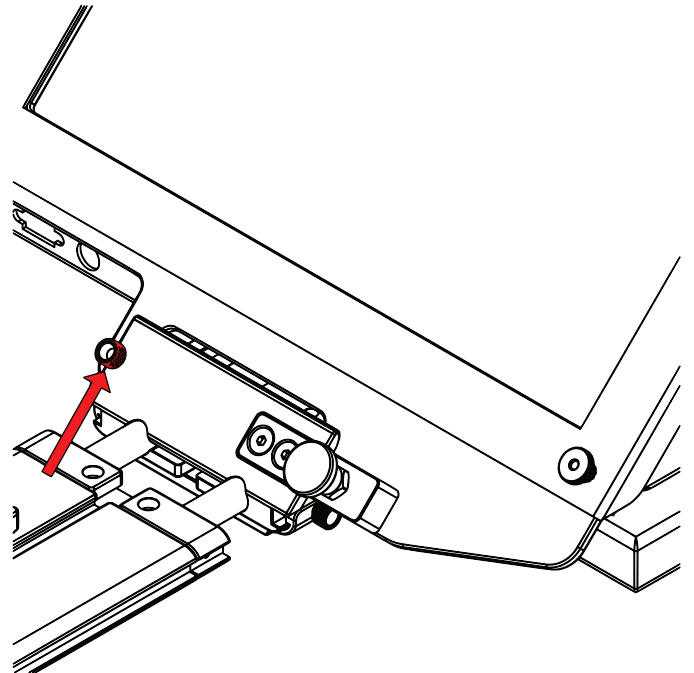

Step 8

Fold the flaps of the Hood alongside the edges of the Hood Attachment Frame. The Hood Attachment Frame includes six threaded clinch studs. Make sure to put the holes on the hood through the threaded clinch studs. The flaps of the Hood are magnetic so they will automatically attach and give extra support.

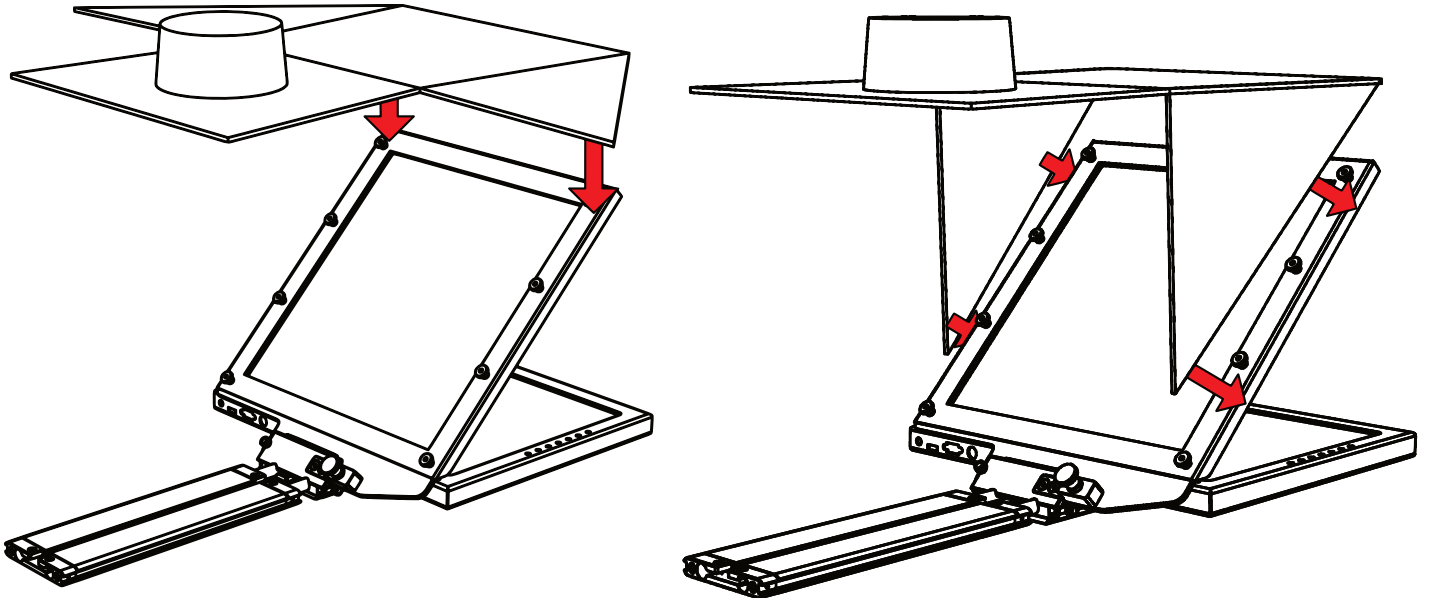

Step 9

To prevent light from leaking through the hood, seal both zippers down.

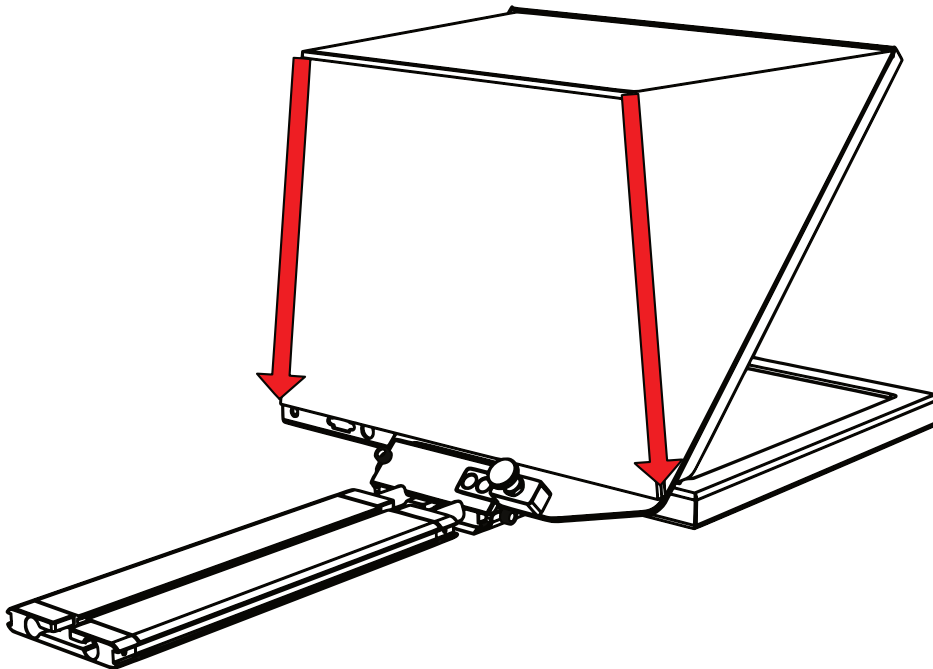

Step 10

Locate the threaded clinch studs on the Hood Attachment Frame and fasten the included nuts to the clinch studs.

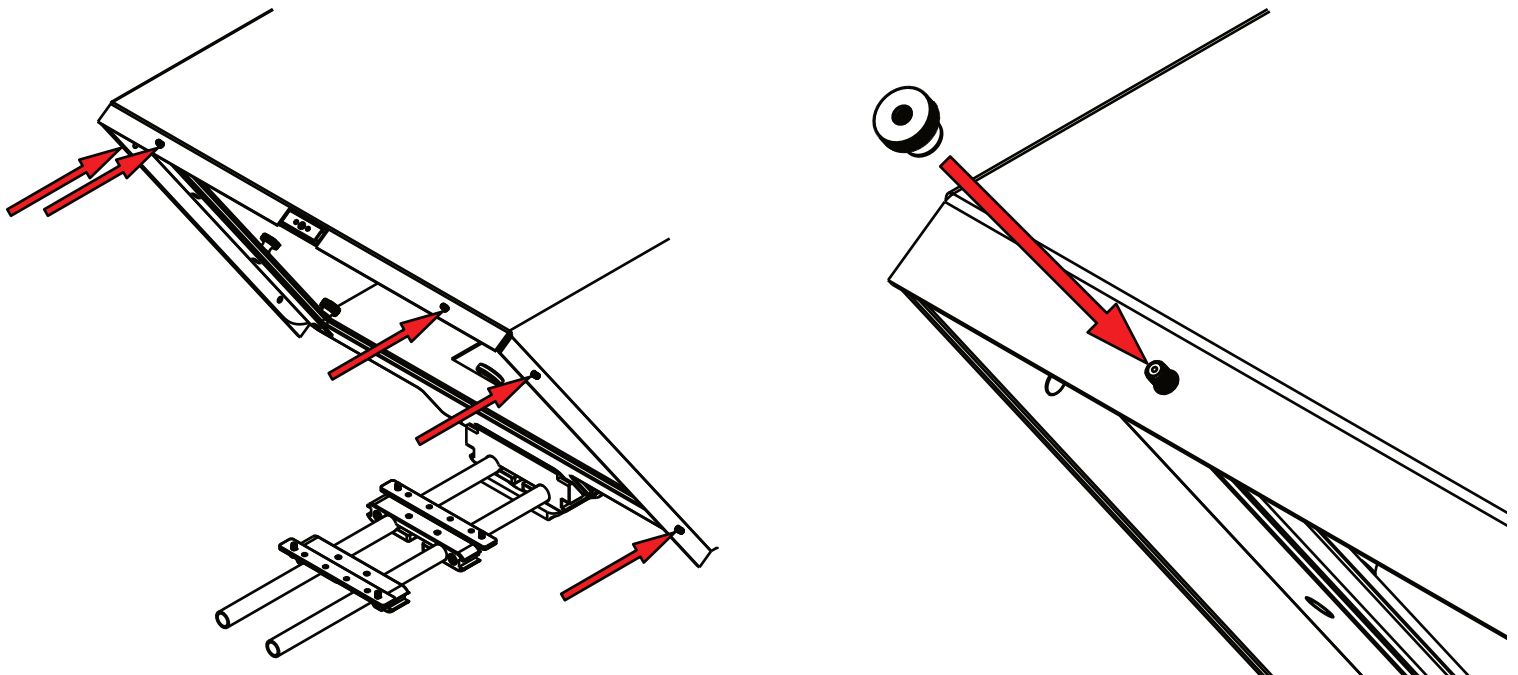

Step 11

Fasten all six of the nuts to the threads on the hood frame to secure the hood to the teleprompter.

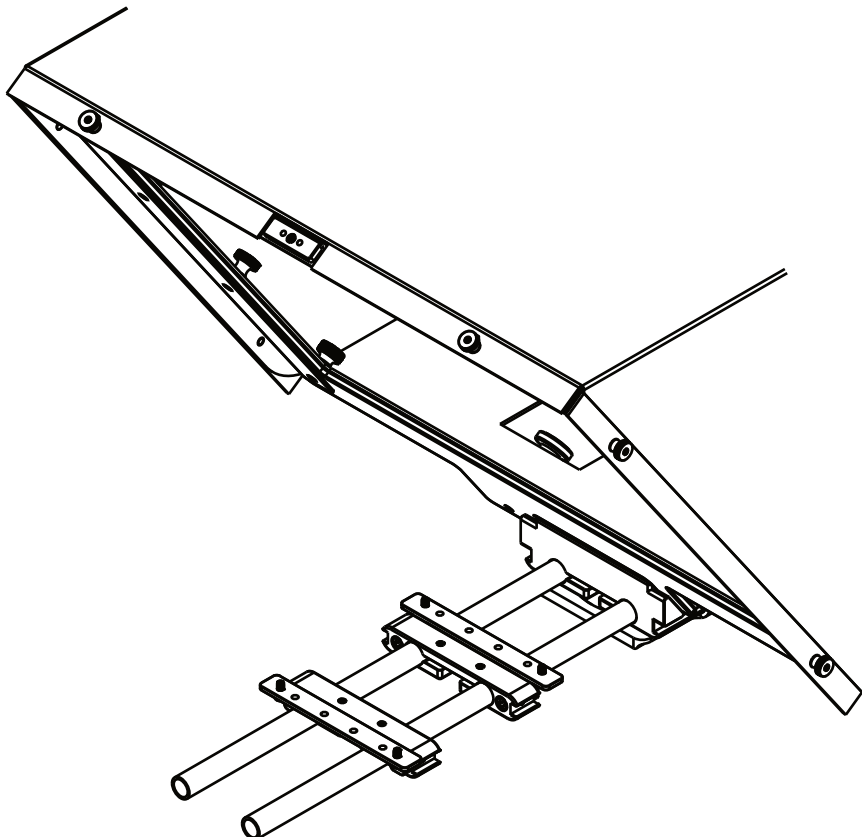

Step 12

If you need to use the Tall Riser Plate, you will need to use the Large Riser Bracket. Insert the Large Riser Bracket through the channel on the Tall Riser Plate. The Large Riser Bracket includes a location pin for use with cameras that feature a location pin hole. If your camera does not feature a location pin, you can remove the location pin by unscrewing it.

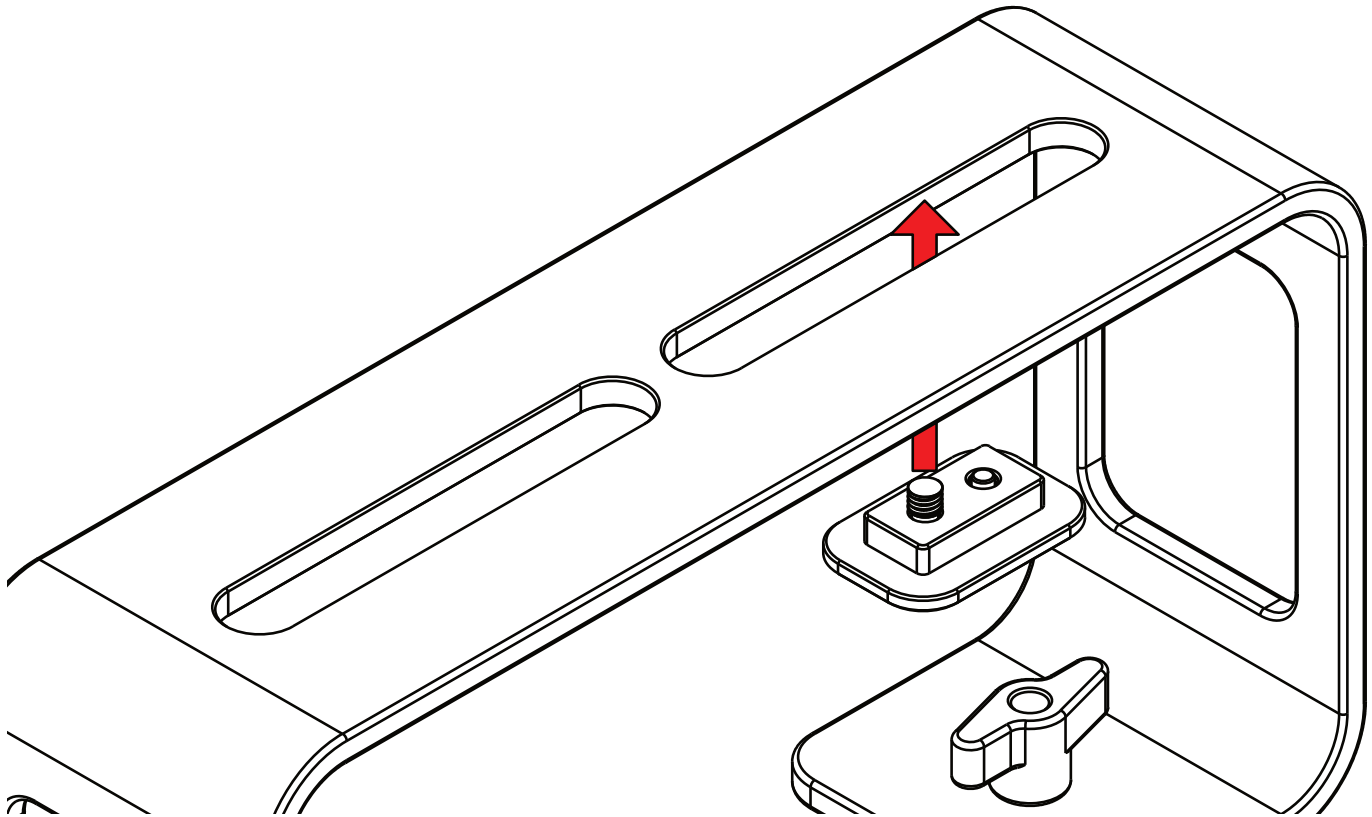

Step 13

Once the Large Riser Bracket is inserted into the channel. Hold it in place and move on to Step 14.

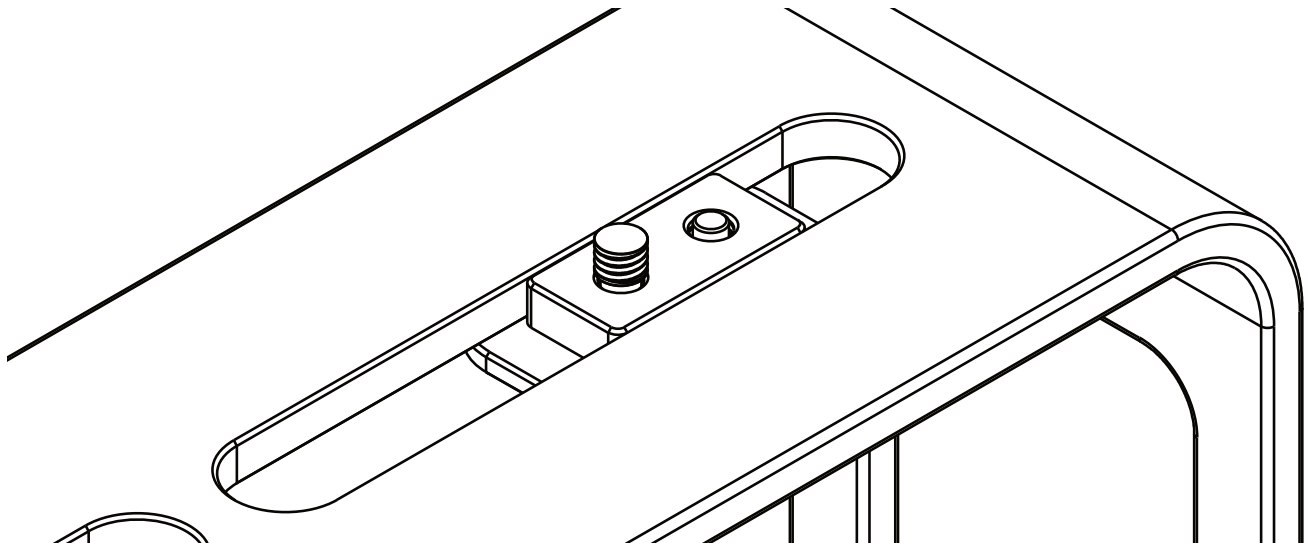

Step 14

Place the riser below your camera and fasten the 1/4-20 camera screw to the bottom of your camera to secure it to the riser plate.

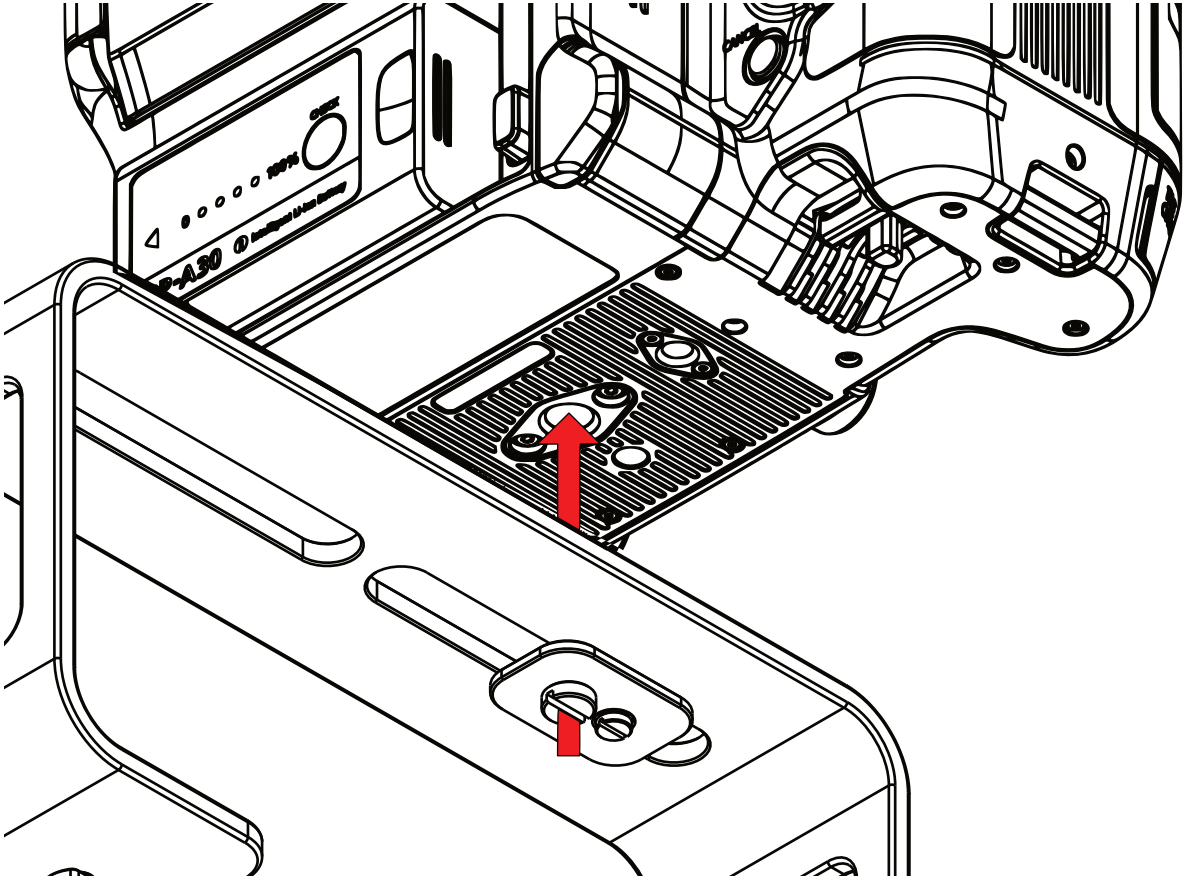

Step 15

Slide the threaded studs into the channel of the base. Make sure they are aligned to the spacing of the holes on the riser plate.

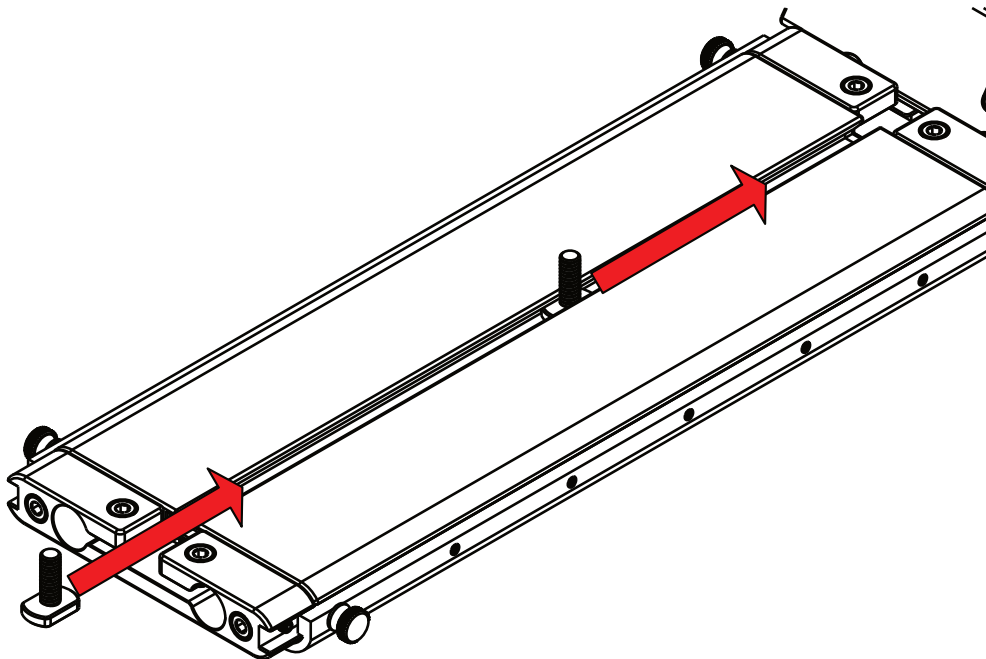

Step 16

Once the threaded studs are aligned to the holes of the riser plate, put the threaded studs through the holes of the riser plate.

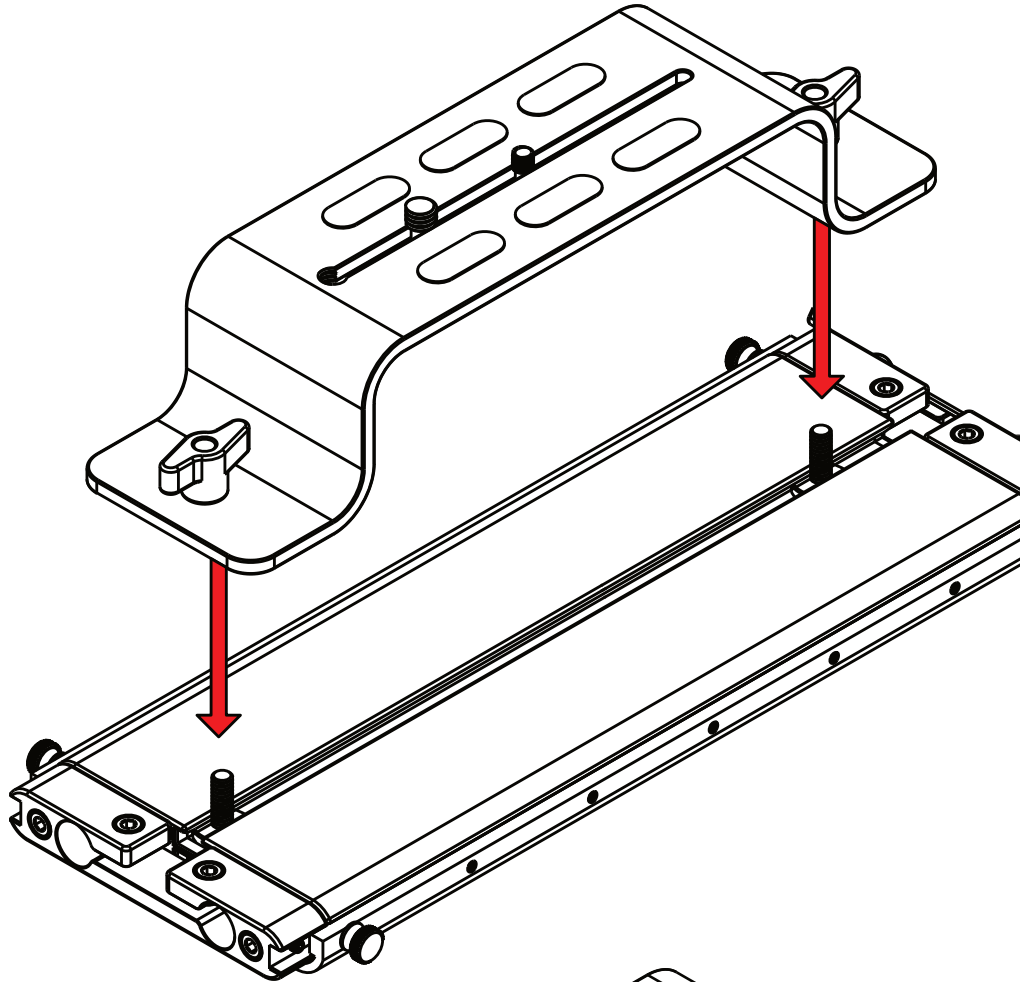

Step 17

Fasten the screws to the threaded studs to secure the riser plate to the base.

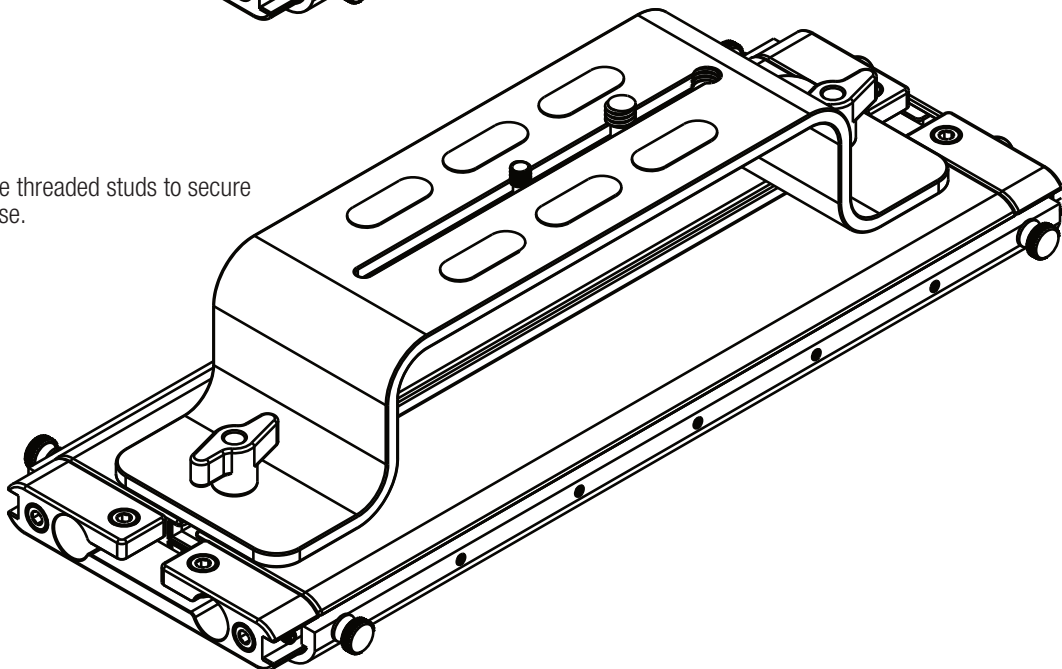

Step 18

Mount your own tripod plate to the sled by aligning the 1/4-20 and/or 3/8-16 screws and fastening them to the Sled. It is recommended that you connect your tripod plate to front of the Sled so that you can balance your teleprompter easier. Once your tripod plate is connected to the Sled, mount the tripod plate to your tripod head.

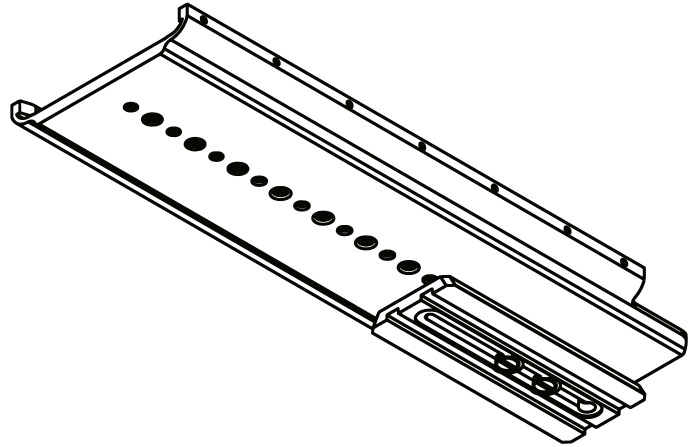
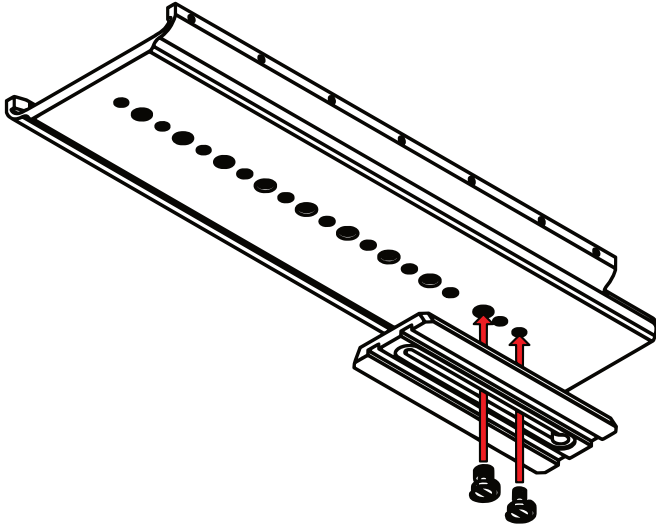

Step 19

Slide the entire teleprompter system into the Sled. Once the teleprompter system is inserted, you can balance it by sliding it along the Sled until the center of gravity is determined.

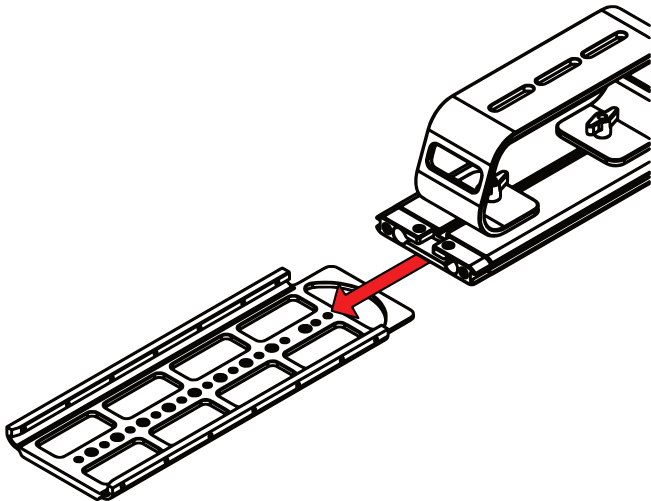

Step 20

Once the center of gravity has been determined, tighten the thumb screws to keep the base from sliding.

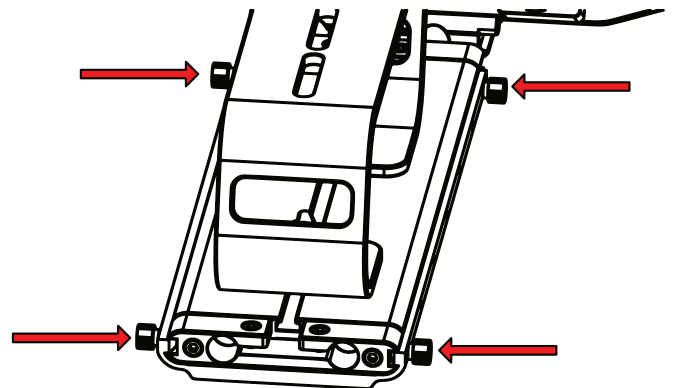

Step 21

To secure your teleprompter system, insert the included headless screws into the threads behind and in front of the Base.

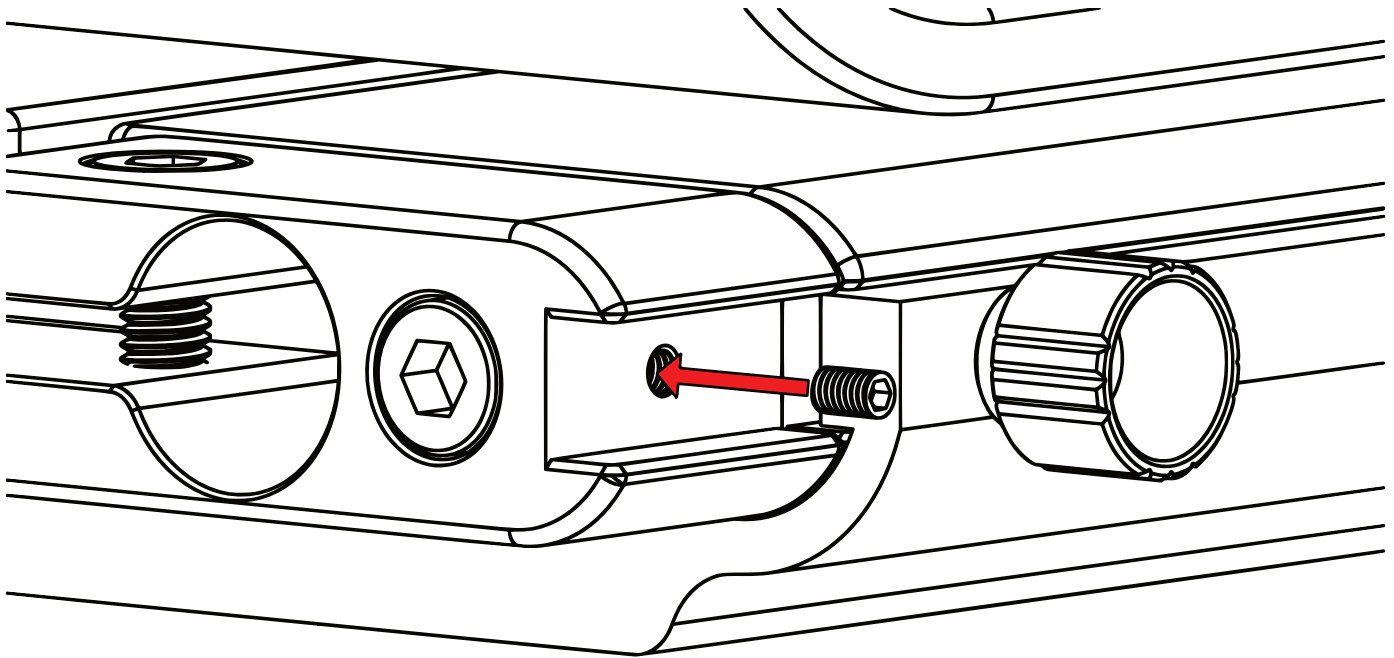

Step 22

The headless screws should be inserted to the threads as pictured below.

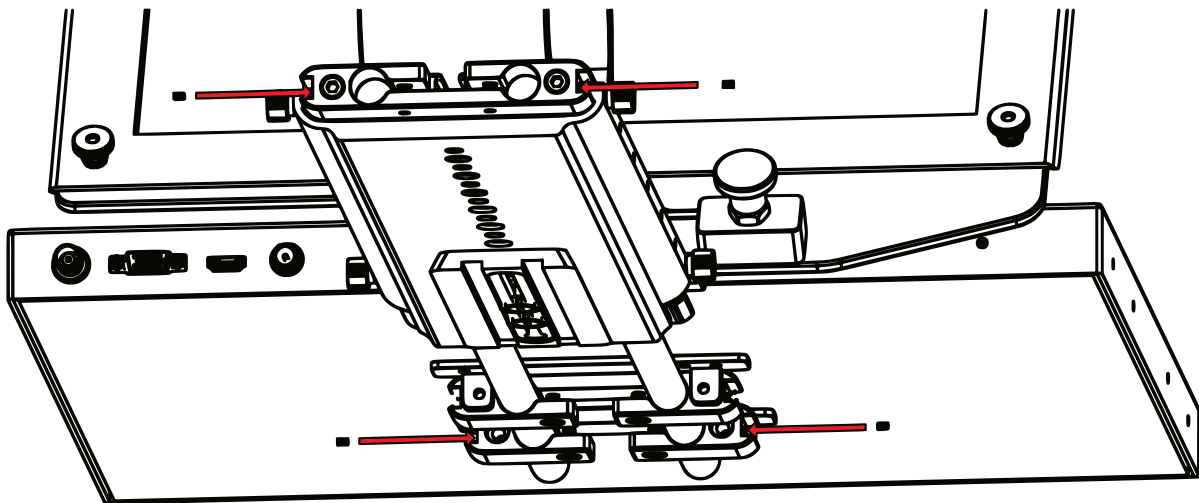

Step 23

Align the holes of the monitor to the VESA Adapter.

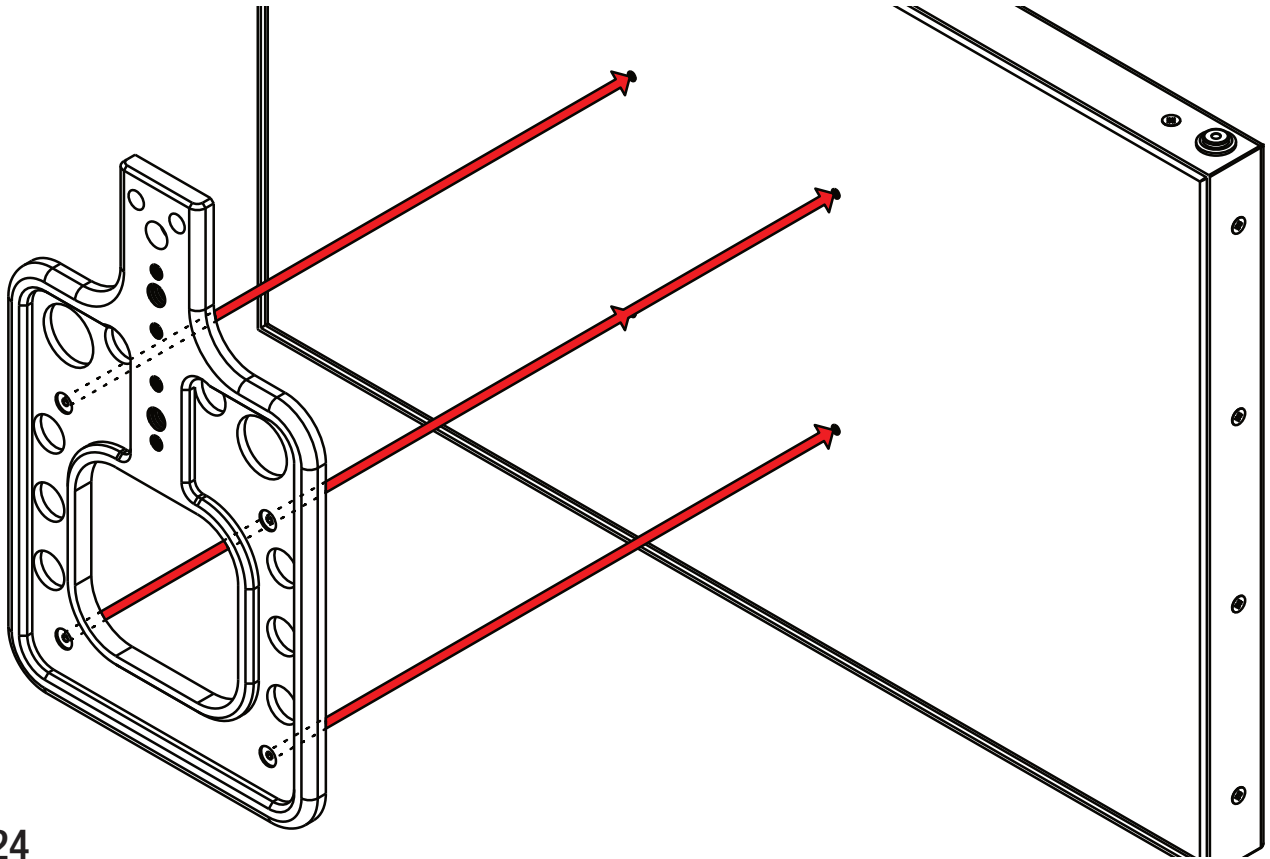

Step 24

Attach the VESA adapter to the monitor by fastening the screws to the monitor

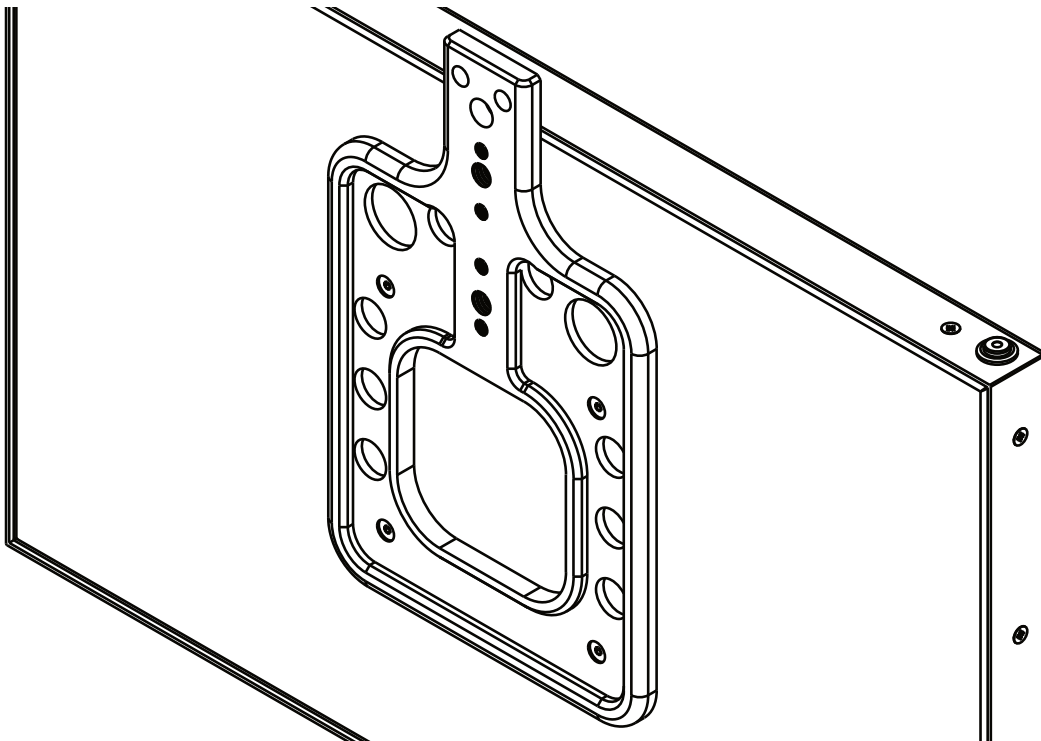

Step 25

Place the Height Adjustment Plate in the Rod Adapter and align the holes.

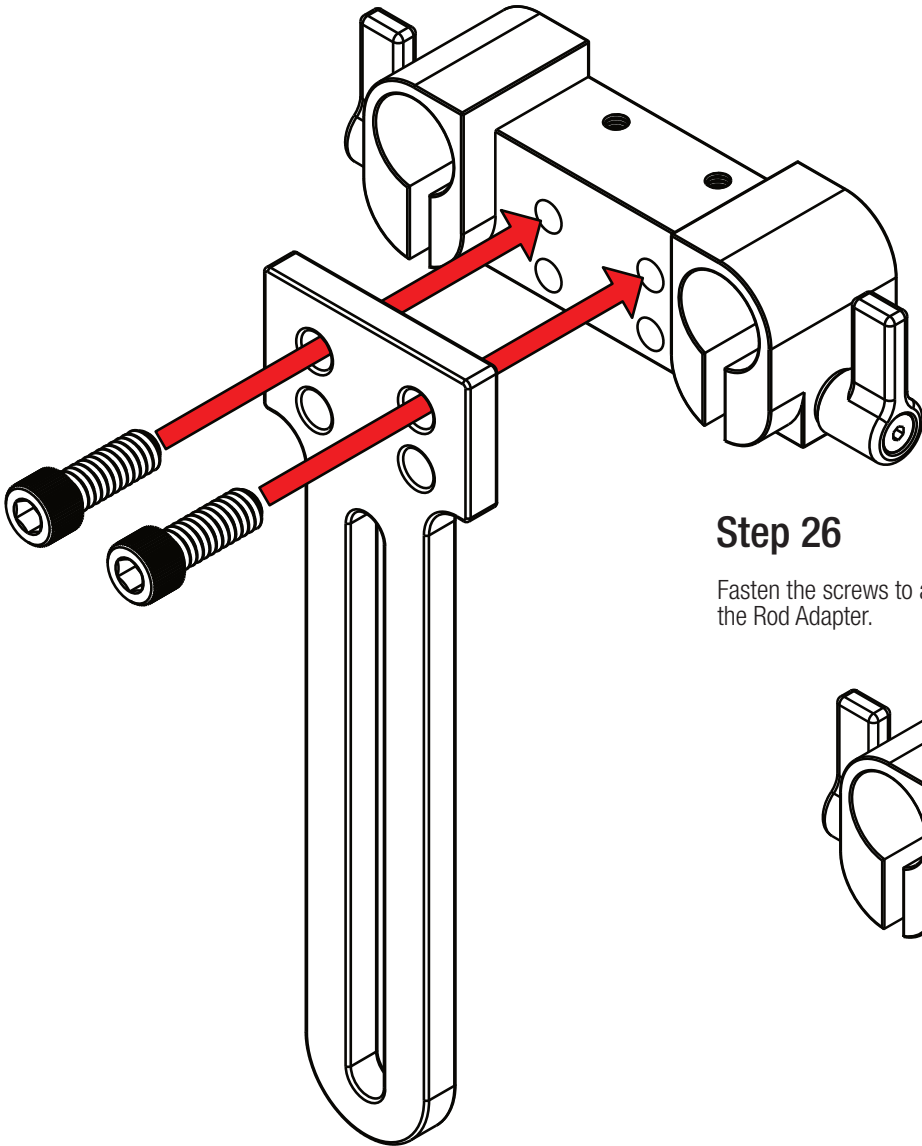

Step 26

Fasten the screws to attach the Height Adjustment Plate and the Rod Adapter.

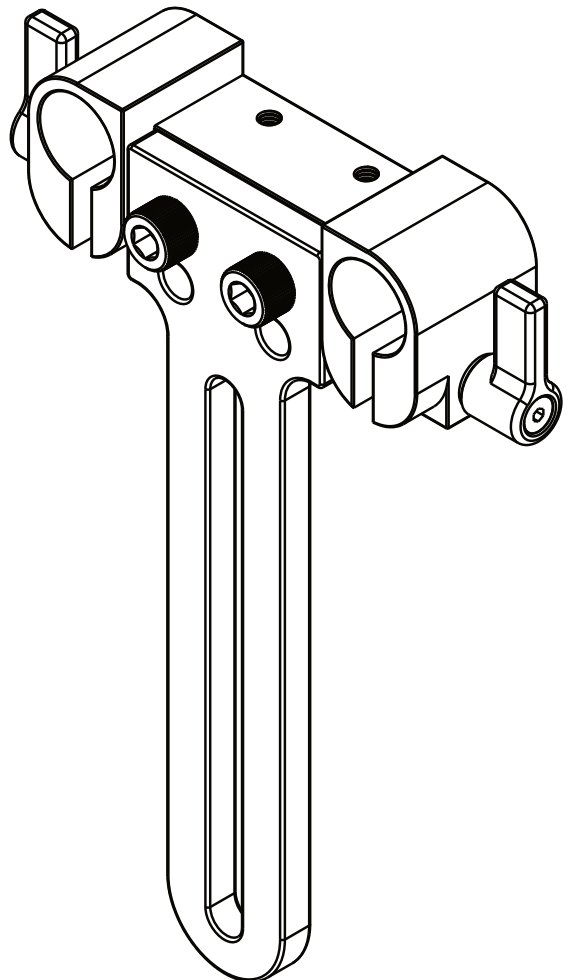

Step 27

Align the threads of the 1/4-20 thumb screw to the threads on the VESA Adapter.

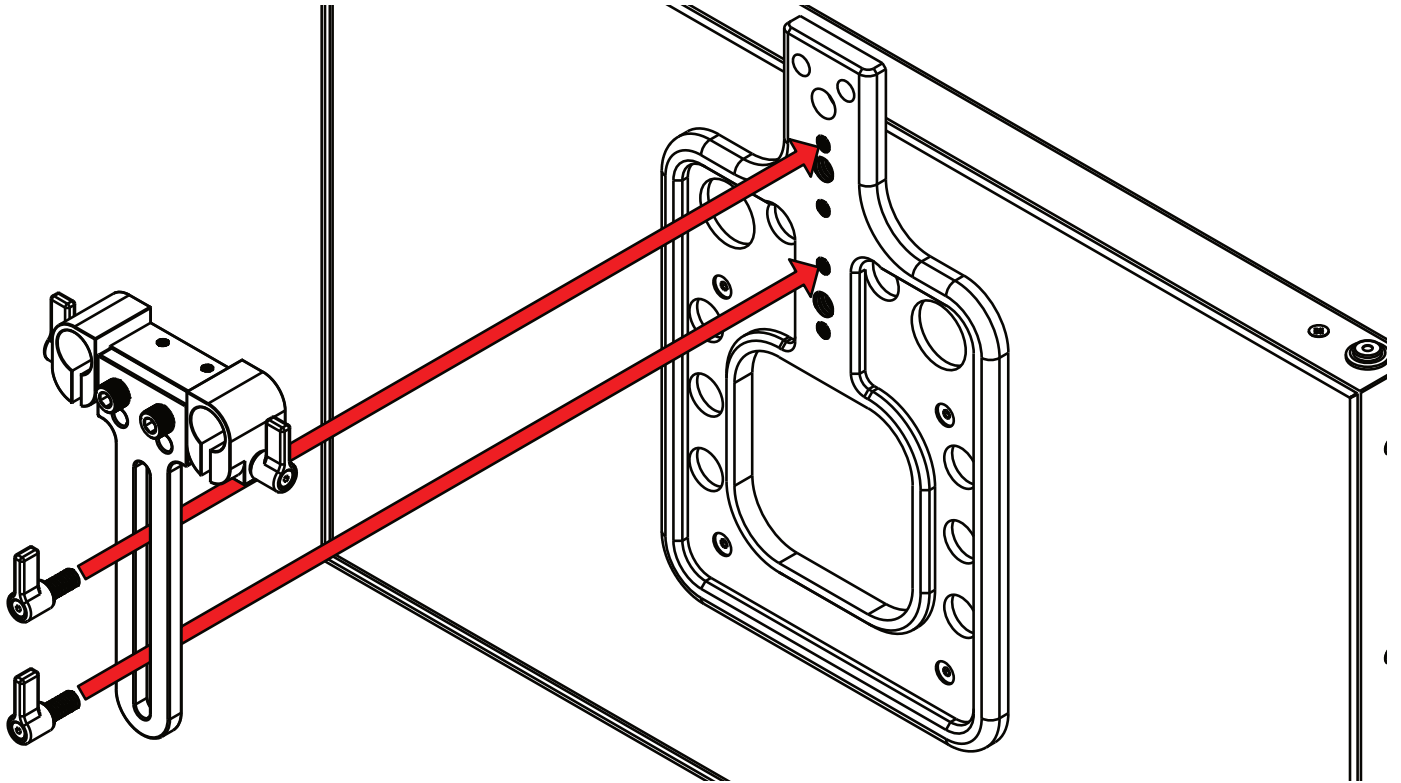

Step 28

Fasten the screws to secure the Talent Monitor to the Rod Adapter.

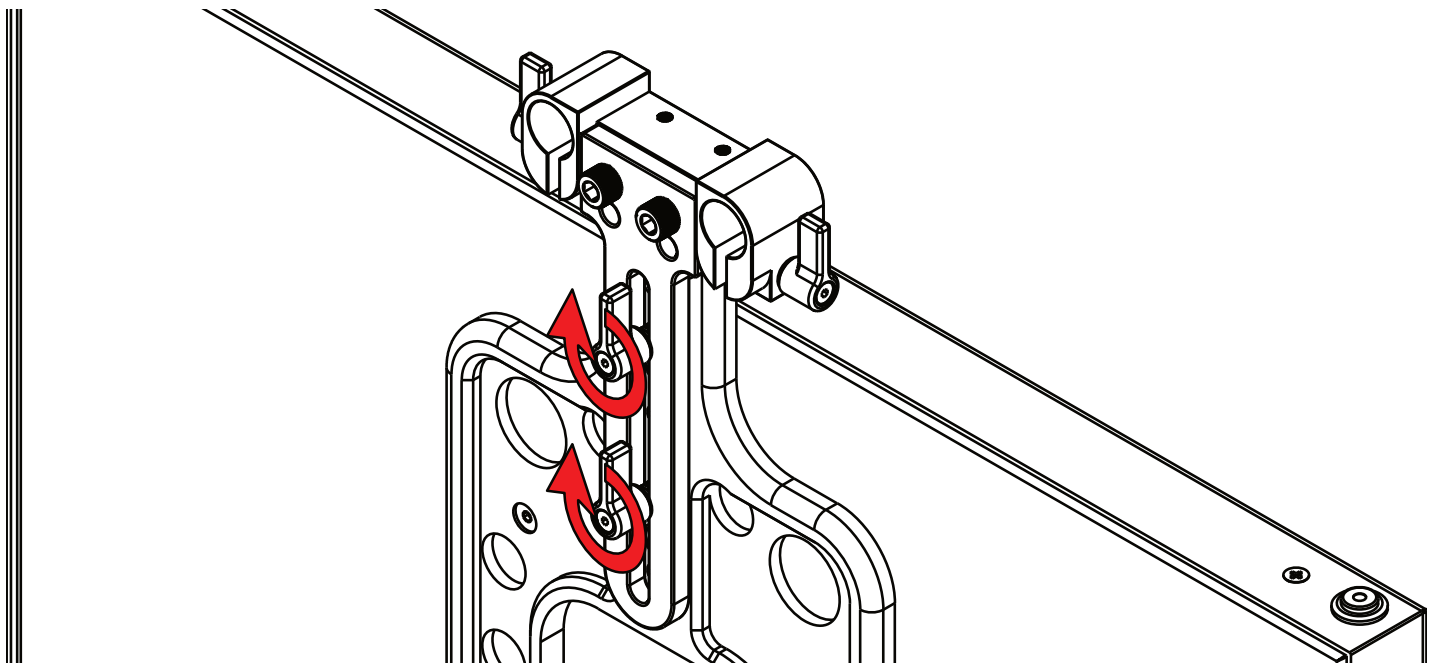

Step 29

Attach the Talent Monitor Mount to the Teleprompter system by inserting the Rod Adapter to the 15mm rods.

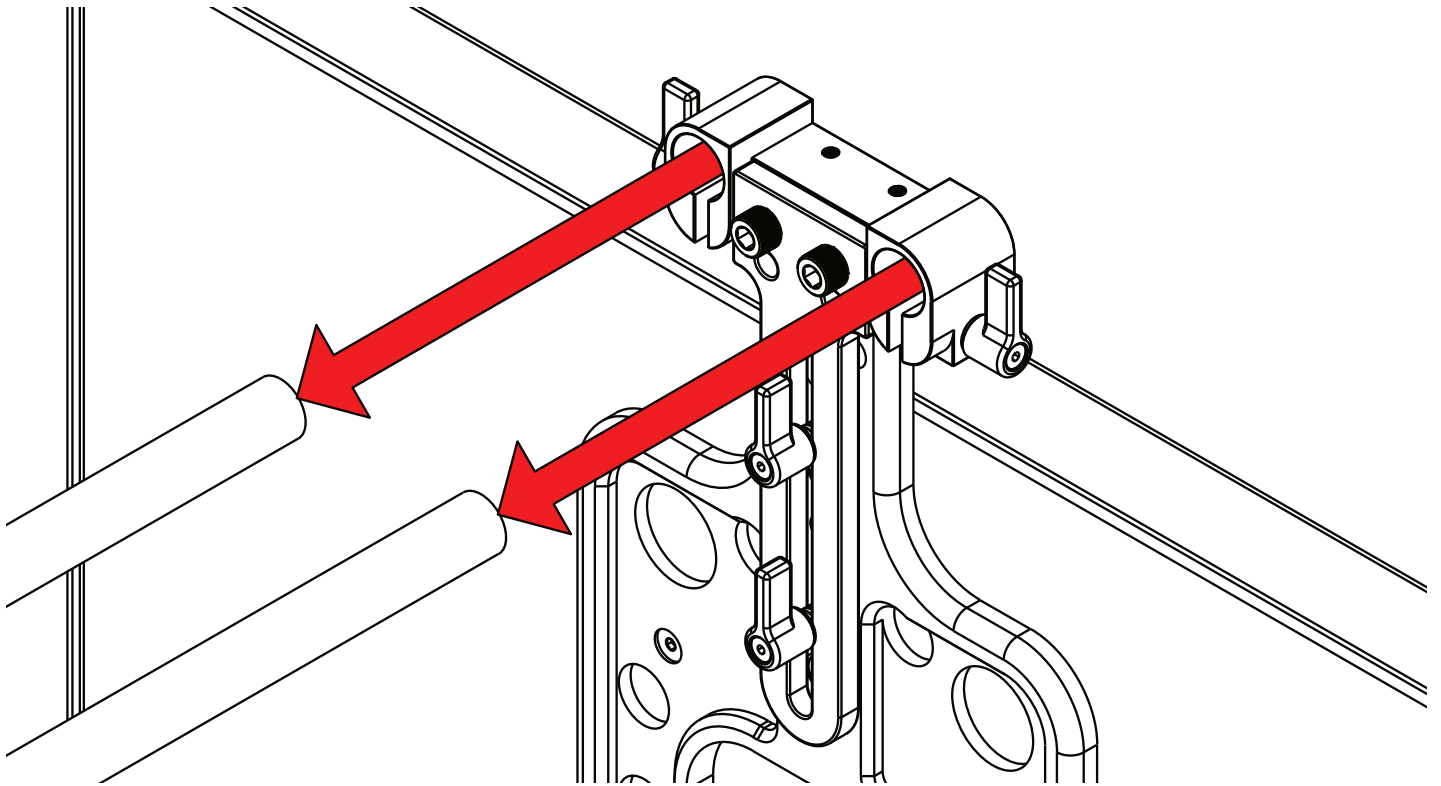

Step 30

Once the Talent Monitor Mount has been inserted to the 15mm rods, secure the Talent Monitor by fastening the thumb screws.

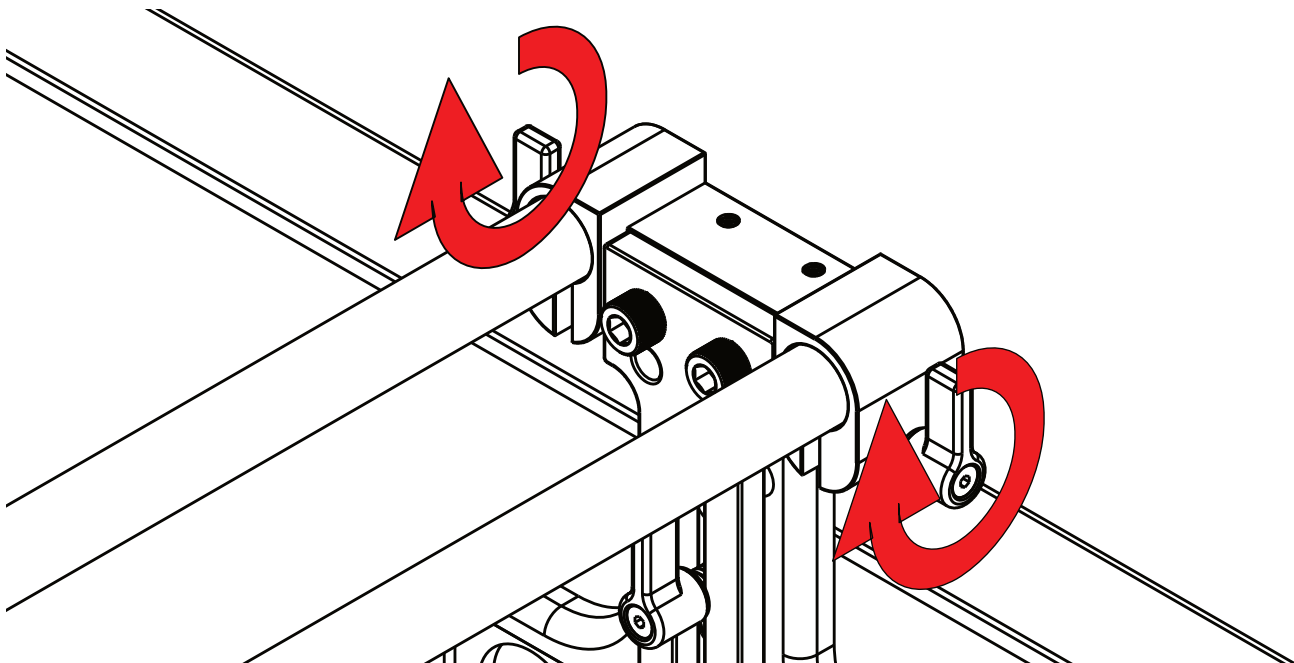

Monitor Ports

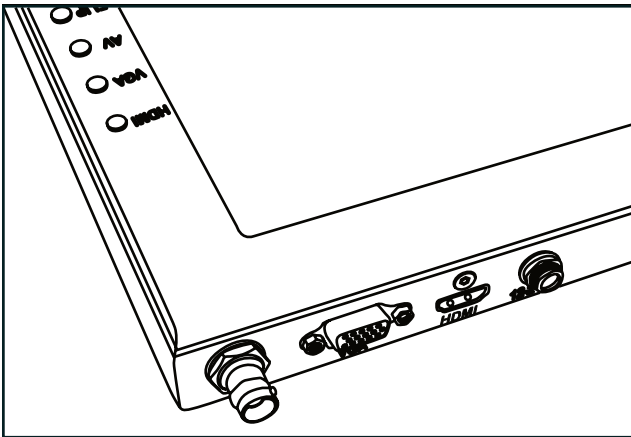

BNC – AV Composite Input
VGA – Video Graphics Array DE15 Connection
HDMI – High-Definition Multimedia Interface Input Connection
Power Port – 12-24v Input

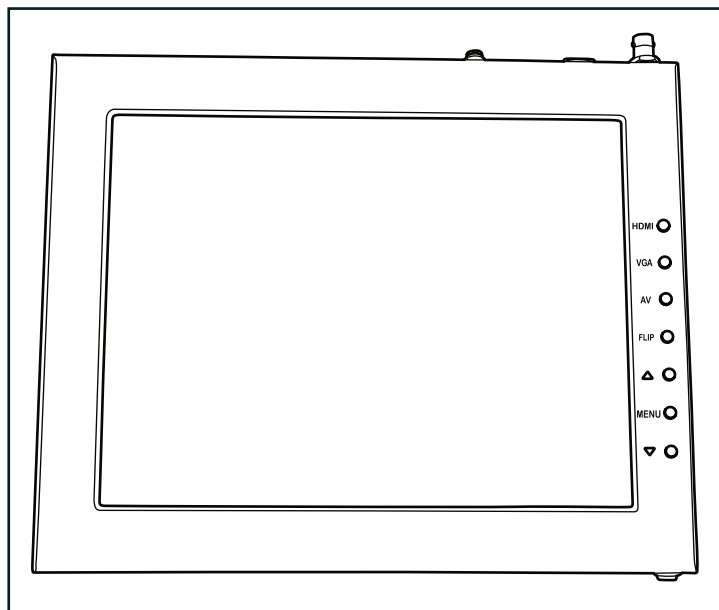

HDMI – Switch HDMI input
VGA – Switch to VGA input
AV – Switch to composite BNC input
Flip – Toggle image flip
(Can be set to horizontal, vertical, or both via menu)
Up Arrow – Toggle up to adjust setting
Menu – Access to monitor settings
Down Arrow – Toggle down to adjust setting

Monitor Menu Settings

Video Config

- Contrast (White Level)
- Brightness (Black Level)
- Tint (Chroma Hue)
- Chroma (Chroma Saturation)
- Sharpness (Detail)
- RGB Setup – Manually configure RGB
- Return

System Config

- Menu Duration – Set duration of how long menu stays on screen
- Video Ratio – Set screen aspect ratio 16:9 or 4:3 (4:3 is native resolution, 16:9 will create black bars)
- Flip-H – Assign toggle button to flip image horizontally
- Flip-V – Assign toggle button to flip image vertically
- Reset – Factory reset
- Return

PC Setup (Only available for VGA)

- H-Position – Adjust horizontal position
- V-Position – Adjust vertical position
- Auto – Monitor automatically adjust position
- Return

Exit

How to set-up FLIP button feature:

1. Press MENU button
2. Navigate to SYSTEM CONFIG.
3. Navigate to FLIP-V or FLIP-H
4. Change FLIP-V and/or FLIP-H to "ON"
5. Exit MENU
6. The FLIP button should now be activated and can be pressed to mirror the image Horizontally or Vertically
7. When FLIP-H is ON, the image will flip Horizontally
8. When FLIP-V is ON, the image will flip Vertically
9. If both are ON, the FLIP button will toggle both Horizontal and Vertical flip

Watch our VIDEO TUTORIAL on how to assemble PT4900-V2 Teleprompters:

<https://ikancorp.com/pt4900-v2-tutorial-videos/>



Specifications

PT4900-V2

19 in. Teleprompter

Riser Plate Height	Short: 2.06 in./52.5mm Tall: 5.31 in. /135mm DSLR: 6.29 in./160mm
Length of Rods	15mm x 400mm
Build Material	Chassis: Anodized Aluminum Rods: Carbon Fiber
Reading Range	25 ft. / 7.62 m
Beamsplitter Ratio	65/35
Beamsplitter Shape	Rectangular
Beamsplitter Material	Glass
Tripod Mounts	11 x 1/4 in. -20 Female 9 x 3/8 in. -16 Female
Product Weight w/ Low Plate	29.6 lbs.
Product Weight w/ Medium Plate	30 lbs.
Product Weight w/ High Plate	30.13 lbs.
Product Weight w/ DSLR Plate	29.5 lbs.
Height of Teleprompter	16.1 in./ 411mm

19 in. Teleprompter Monitor

Aspect Ratio	4:3
Maximum Brightness	1000 cd/m2
Screen Size (Diagonal)	19 in.
Mount	VESA 100mm
Video Inputs	AV COMPOSITE, HDMI, VGA
Input Voltage	DC 12v / 4A
Power Consumption	21W
Product Weight	6 lbs.
Product Dimensions	17 in. x 15 in. x 1 in.
Native Resolution	1280 x 1024
Viewing Angle	160° (H) / 170° (V)
Build Material	Aluminum Chassis
Image Flip	Horizontal: Yes Vertical: Yes

Optional Accessories

PT4U-G	Replacement Glass for PT4900-V2
M19W-V2	19" Talent Monitor Add On Kit for PT4900-V2
PT-PEDAL	Teleprompter Foot Control Pedal
PT-CONTROLLER	Teleprompter Rotary Controller
PT-CASE-4U	Rolling Hard Case for PT4900 Teleprompter



Foam Case

To make your teleprompter more portable, we packed it in a reusable, high-quality foam. The shape and size of the foam was designed to fit into Ikan's PT-CASE-V2.



****DO NOT THROW AWAY FOAM CASE****

Learn More

More dynamic information at official website: www.ikancorp.com

Support

Contact email: support@ikancorp.com

CONDITIONS OF WARRANTY SERVICE

- Free service for one year from the day of purchase if the problem is caused by manufacturing errors.
- The components and maintenance service fee will be charged if the warranty period is expired.

Free Service will not be Provided in the Following Situations: (*Even if the product is still within the warranty period.)

- Damage caused by abuse or misuse, dismantling, or changes to the product not made by the company.
- Damage caused by natural disaster, abnormal voltage, and environmental factors, etc.

©2024 Ikan International. All rights reserved.



SUPPORT YOUR IMAGE

NINGBO EIMAGE STUDIO EQUIPMENT CO., LTD

Add: No.1230 South Cihai Rd, Luotuo Industry zone, Zhenhai,
Ningbo, China. 315202
Tel: +86-574-86590031/86590061
E-mail: sales@eimagevideo.com

Visit www.eimagevideo.com for more information



E-IMAGE
Official QR Code



EG25A2
Video Tripod System

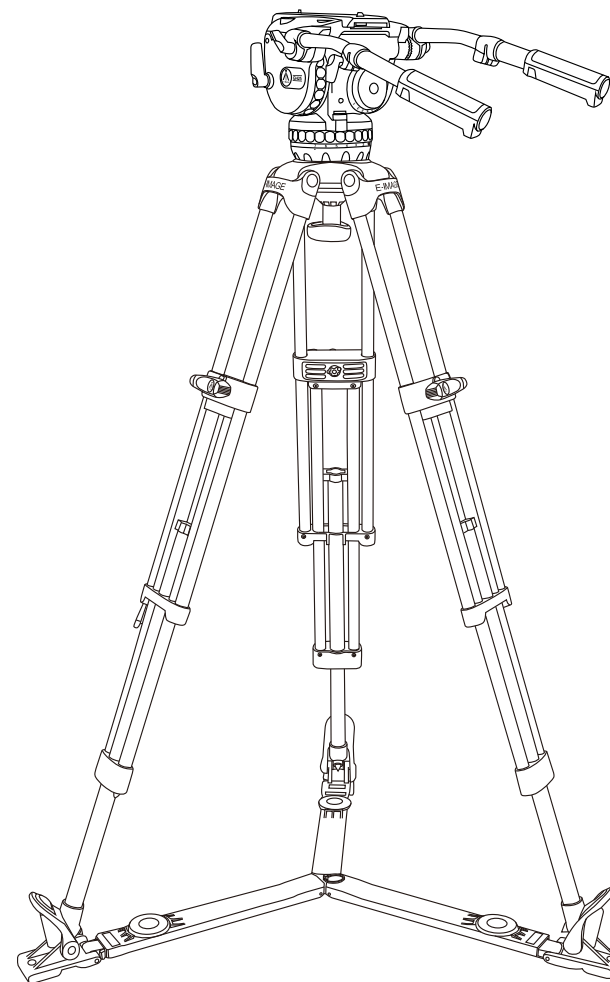

www.eimagevideo.com

Contents

Safety Instructions

In The Box	1
EG25A2 & GH25 Technical Data	2
GH25 Fluid Head	3-4
Fluid Head Set-up	5
Camera Mounting	6
Balance Adjustment	7-8
Counterbalance Setting	9
Setting of the Damping	10
Pan and Tilt Locks	10
Illuminated the Bubble Level	11
Battery Replacement	11
GA102 Technical Data	12
Tripod Using	13-14
Daily Maintenance	15
Warranty Card	16

Safety Instructions

Thanks for purchasing E-IMAGE products.

We encourage you to read this manual carefully to familiarize yourself with all the detailed features before operating it, as some of them may be new to you. The manual includes all safety instructions, operation guidelines, and maintenance procedures. Please ensure that all equipment is operated correctly to avoid any defects or damage, especially ensuring that the tripods are steady, and the head is securely locked and leveled.

1. Please don't exceed the max. payload of head.
2. Please lock the tripod leg tightly before mounting camera on.
3. Please make sure the head is locked tightly on the tripod.
4. Please add accessories to the camera before adjusting the balance.
5. Please don't leave the camera unattended on the fluid head and keep it out of reach of children.
6. Please don't adjust the height of the tripod while the camera is mounted.
7. Please keep the quick release plate locked during use.
8. Please keep the tilt & pan is locked when adding/removing accessories from camera.
9. Please securely hold the camera while adjusting the balance, counterbalance, tilt drag, and pan drag.
10. Please remove the camera from the tripod before transportation.

For the latest product information, please visit www.eimagevideo.com and click on the product page.

The product packing comes with the following items. In case that any item is found missing, please contact E-IMAGE or your local selling agent.

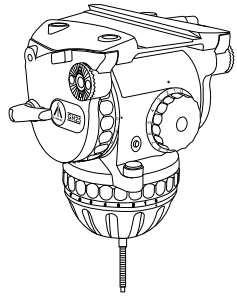

GH25 Fluid Head x 1 PC

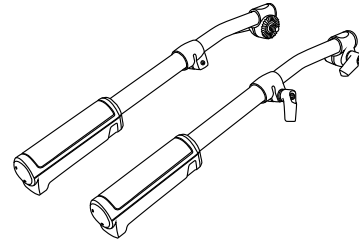

GB4 Pan Handles (Left & Right) x 2 PCS



100L Bowl Locking Knob x 1 PC

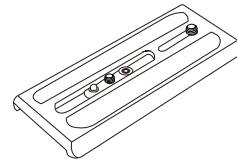

GP2 Quick Release Plate x 1 PC

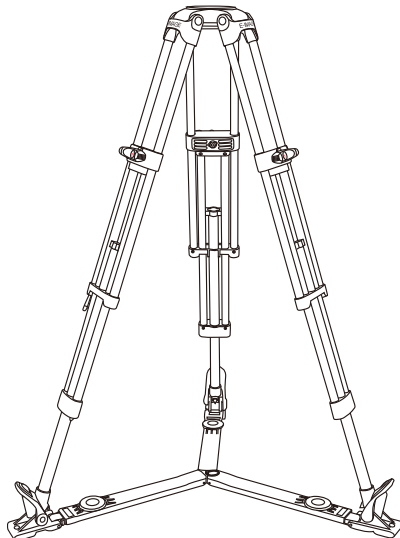

GA102 Tripod x 1 PC

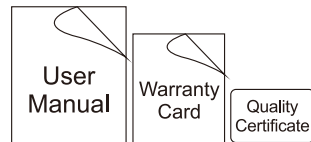

User Manual / Warranty Card / Quality Certificate x 1 PC

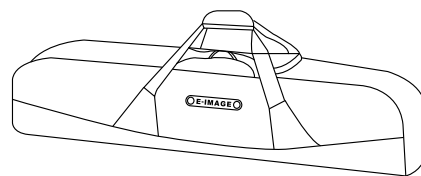

T20 Carrying Bag x 1 PC

EG25A2 Technical Data

Model	EG25A2
Fluid Head	GH25
Tripod	GA102
Payload	28kg / 61.7lbs
Net Weight	9.2kg / 20.2lbs
Height Range	64.5~177.5cm / 25.4~69.9in
Temperature Range	91.5cm / 36.0in
Bowl Size	100mm
Packing	T20

GH25 Technical Data

Model	GH25
Payload Range	3-28kg / 6.6-61.7lbs
Safety Payload	32kg / 70.4lbs
Counterbalance	1-15
Grades of Pan/Tilt Drag	0-7
Tilt Range	-70° ~ +90°
Temperature Range	-30°C ~ +60°C
Bowl Size	100mm
Net Weight	4.6kg / 10.1lbs

GH25 Counterbalance Graph

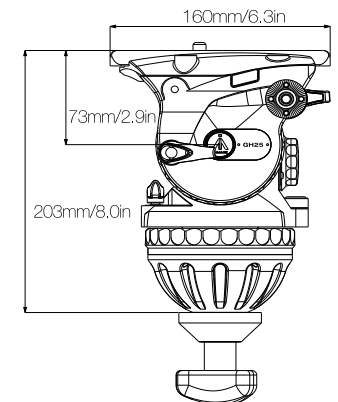
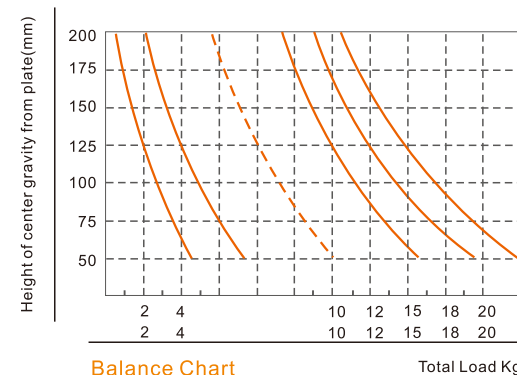

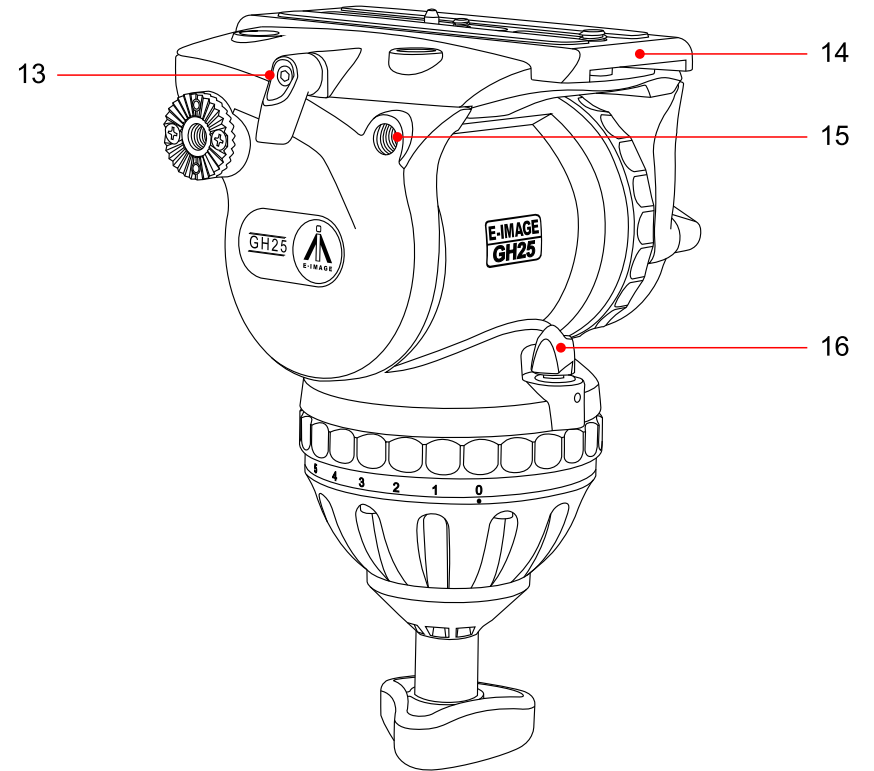
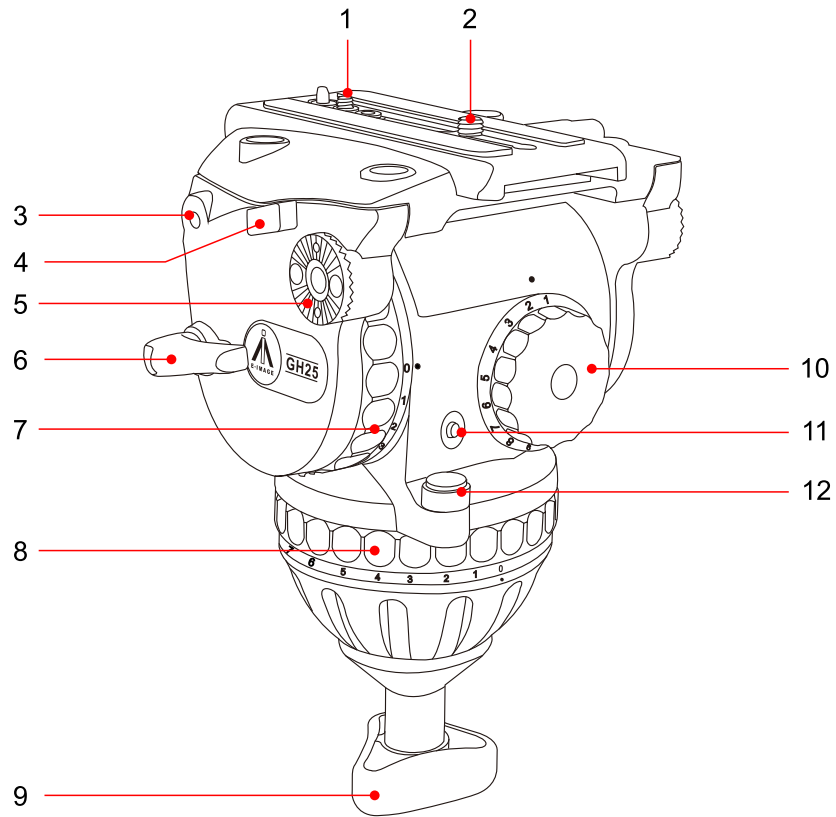

- 1. 1/4" screw
- 2. 3/8" screw
- 3. 1/4" screw hole
- 4. Insurance button
- 5. Handle mounting rosette
- 6. Tilt locking knob
- 7. Tilt damping dial
- 8. Pan damping dial
- 9. Bowl locking knob
- 10. Counterbalance adjustment dial
- 11. Illuminous button
- 12. Bubble level

- 13. Camera plate locking knob
- 14. Camera plate
- 15. 3/8" screw hole
- 16. Pan locking knob

Fluid Head Set-up

① Attach the head on the tripod.

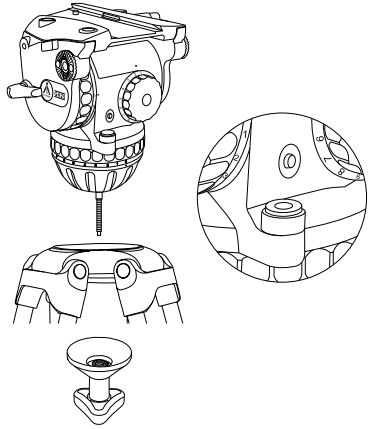

1-1: Please make sure the tripod leg is placed approximately in horizon and tripod leg are locked tightly.

1-2: Place the Head into the tripod bowl, then locking the bowl knob, meanwhile using the bubble level to set the head in level (the bulb in the circle), finally lock the bowl knob tightly.

1-3: Please lock the pan and tilt knob tightly.

② Attach the pan handle.

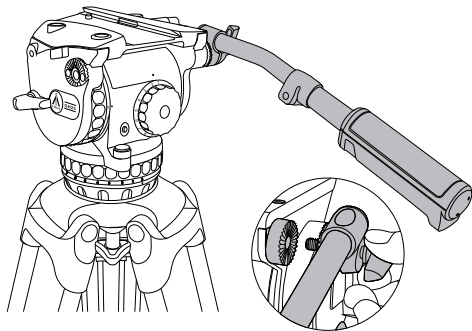

2-1: Install the pan handle on the rosette handle mounts and adjust the position before tightening the clamps.

2-2: Release the knob and adjust the length as you want, then re-lock it.

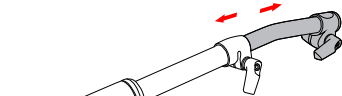

GB4 telescopic pan handle:
425-610mm(16.7-24.0in)

③ Attach quick release plate.

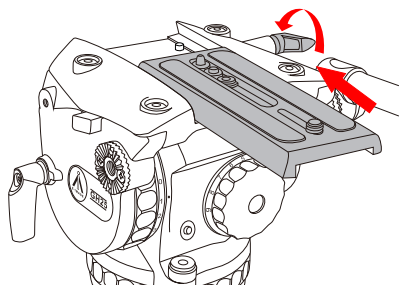

3-1: Slide the camera plate forward until the plate insurance button is engaged, then lock the knob.

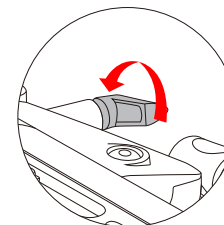

1-3: Slide the camera to appropriate position then locking the plate locking knob.

Camera Mounting

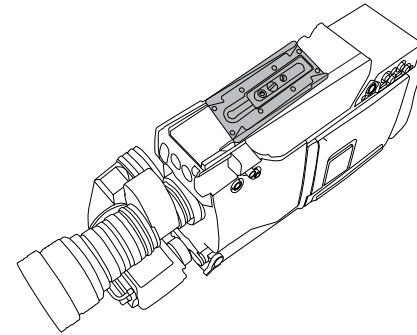

1-1: Attach the quick release plate to the bottom of the camera using the camera screws and pin supplied. Please make sure lock the screws tightly.

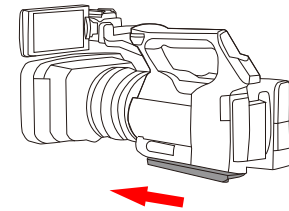

1-2: Hold the camera with one hand, insert the sliding plate onto the rear of the platform. Slide forwards until the plate insurance button is engaged.

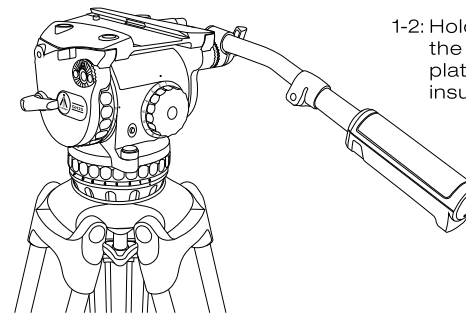

Balance Adjustment

⚠ The center of gravity of the camera should be centered precisely over the axis of fluid head. Please kindly understand that unbalanced payload maybe will fall away suddenly to damage the camera.

- * Please make sure that camera and all accessories are installed before this operation.
- * Please always maintain a firm hold on the camera until balance is achieved.

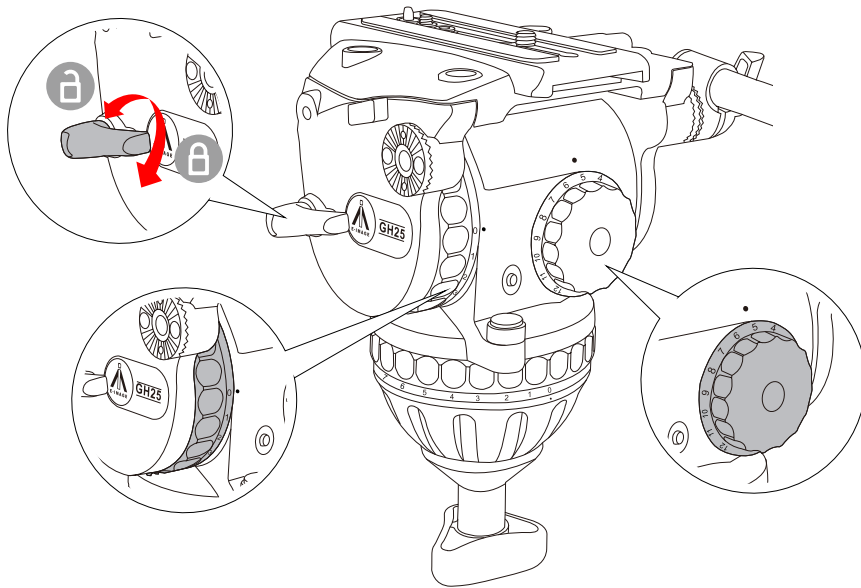

Balance setting

- 1: Adjust the counterbalance to about middle step, such as "7".
- 2: Please lock the tilt locking knob, dia the tilt drag to "0"

Balance Adjustment

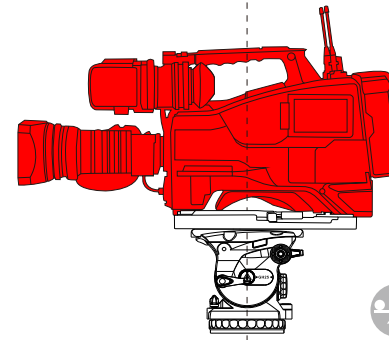

Centre

3: Please hold the camera or pan handle securely in level, then release the tilt locking knob, then observe how the camera moves.

a: If the camera stops in horizon, the balance is achieved.

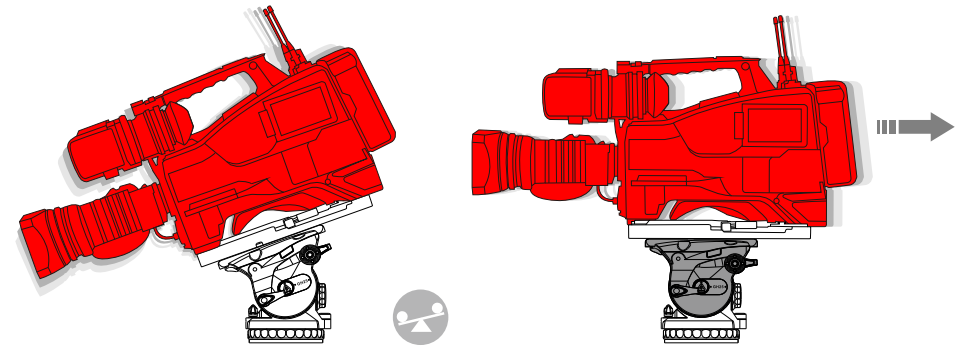

b: If the camera is fall forward (lens points downwards), please carefully slide the quick release plate in backwards.

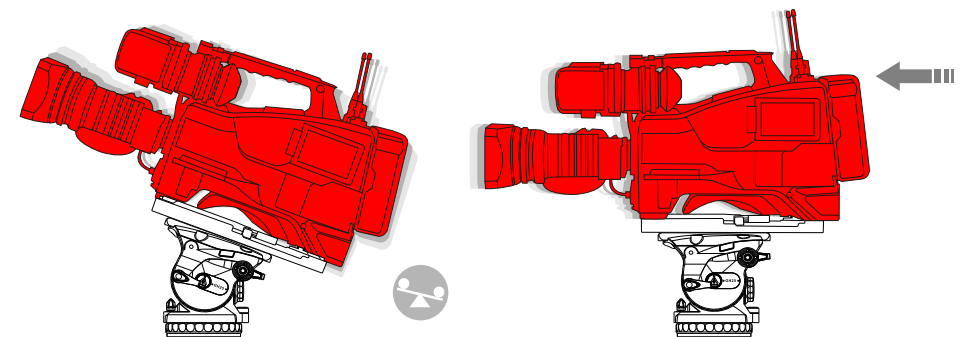

c: If the camera is fall backward (lens points upwards), please carefully slide the quick release plate in forwards. (PS: if necessary, please adjust the camera location on the plate).

* Please repate the operation until the camera could stay in horizontal position. Then lock the plate locking knob and tilt knob tightly.

Counterbalance Setting

The counterbalance system was designed to neutralise the effect of the camera weight when it is tilted. If the correct counterbalance is achieved, the camera should remain in any tilt position, and it could be moved by minimum effort in tilt.

The camera balance must be set before adjusting the counterbalance.

* Please make sure that camera and all accessories are installed before this operation.

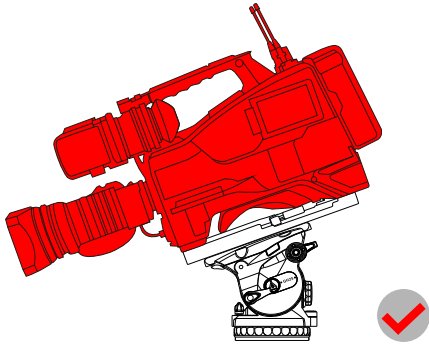

1-1: Hold the camera by securing the pan bar. Turn the counterbalance knob to the number which best compensates for the weights of the camera.

1-2: Releasing the tilt locking knob, tilt the camera upwards or downwards to 45° and release it, pls check if the camera will remain in a fixed tilt position.

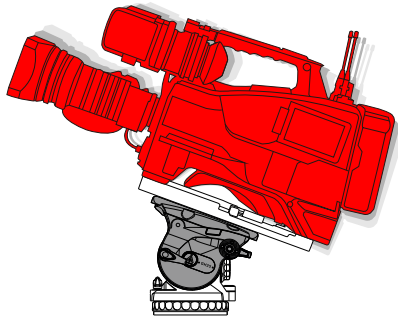

a: If moving upwards, please lower the counterbalance. (Anticlockwise)

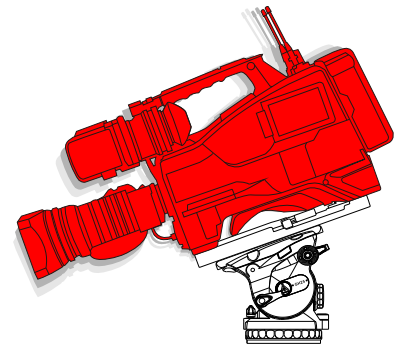
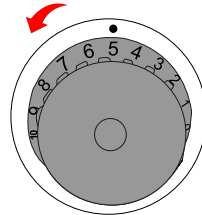

b: If moving downwards, please add the counterbalance. (Clockwise)

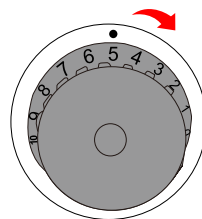

Setting of the Damping

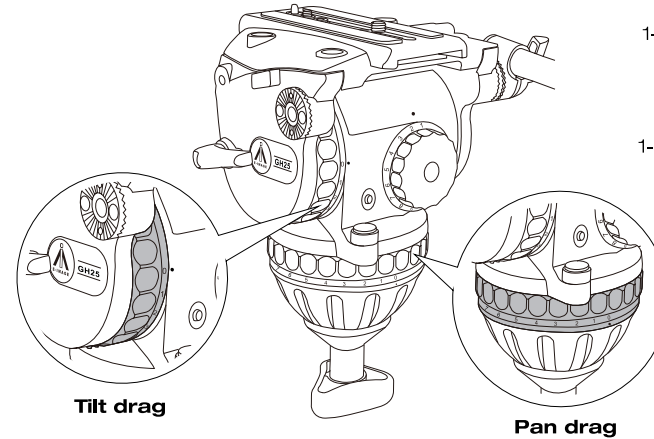

1-1: Tilt drag:
Grades of tilt drag:0-7 steps.
Please dial the tilt drag knob to your desired level.

1-2: Pan drag:
Grades of pan drag:0-7 steps.
Please dia the pan drag knob to your desired level.

Pan and Tilt Locks

The pan and tilt locks should be engaged whenever the camera is left unattended.

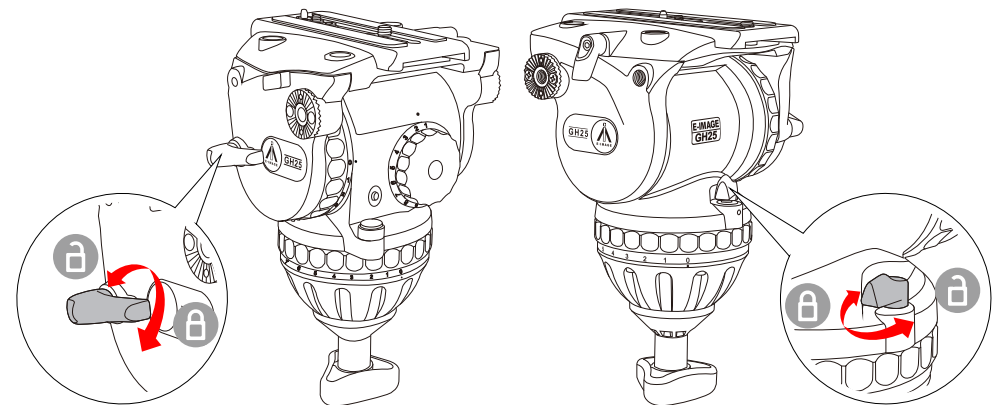

Lock the tilt lock
Turn the tilt lock lever clockwise to lock it.

Lock the pan lock
Turn the pan lock lever clockwise to lock it.

Illuminated the Bubble Level

Press the button, it will help you level the head in poor light. The bubble will be light up to 20s.

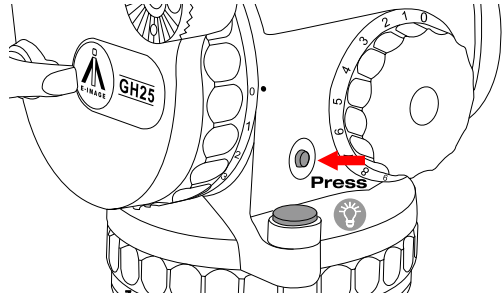

Battery Replacement

The battery illuminates the bubble level. It should be replaced whenever the illumination becomes inadequate.

- 1.The battery slot is on the back of the fluid head.It will appear when you tilt the head to the bottom.
- 2.Use a flat blade screwdriver to unscrew the battery cover.
- 3.Carefully pull the battery out of its compartment.
- 4.Fit a replacement two No.7 batteries in the compartment.
- 5.Replace the battery cover and tighten using a flat blade screwdriver.
- 6.Press the bubble level illumination button and verify that the bubble level is lit for approximately 20 seconds.

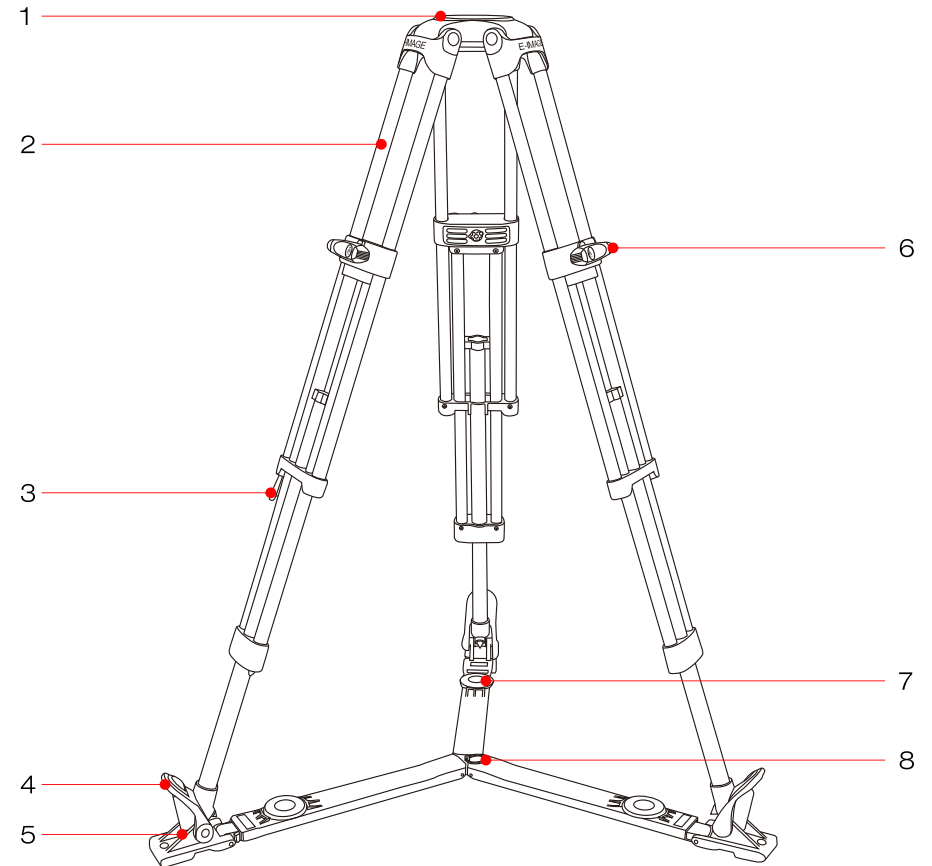
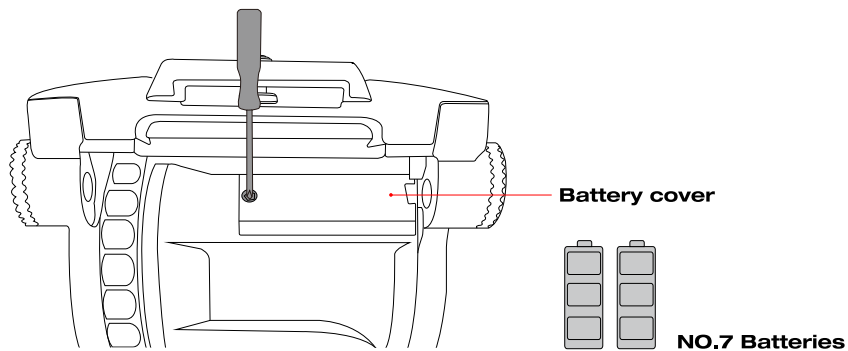

1. 100mm bowl base
2. Leg tube
3. Retractable easy hook
4. Pad-removing tab
5. Spiked feet
6. Locking knob of Leg tube
7. Locking knob of ground spreader
8. Pull ring

Model	GA102
Payload	60kg / 132.0lbs
Height Range	47-160cm / 18.5-63.0in
Transport Length	74cm / 29.1in
Bowl Size	100mm
Sections	3
Material	Aluminum
Net Weight	5kg / 11.0lbs

Tripod Using

① Height adjustment.

* Please remove the tripod clips on the legs, open the tripod and put it on level ground (if possible).

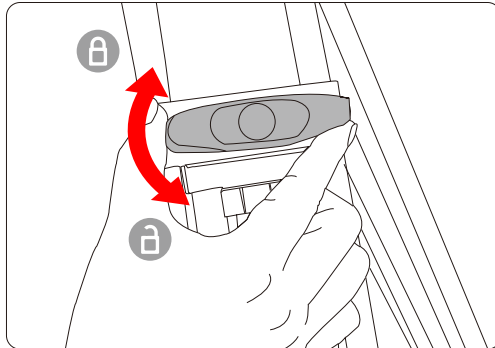

1-1: Loose the locking knob, and lift the tripod to your desired height, then lock it.

1-2: Same operation for other two legs.

* Before put the head on, please make sure the tripod is locked tightly.

② Ground spreader adjustment.

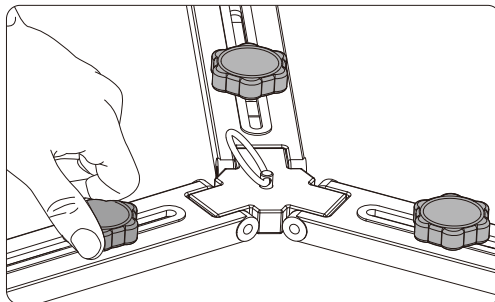

2-1: Loose the locking knob of each arm by turning anti-clockwise, extend the arm to your request length, then re-lock it.

③ Install & remove ground spreader.

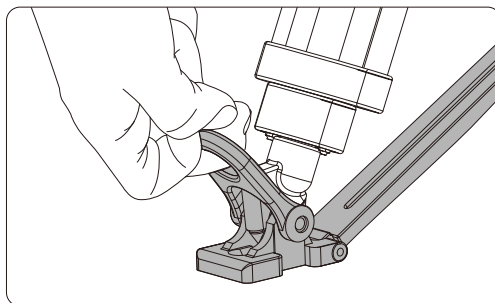

3-1: Illustration as follow pictures, pull the pad-removing tab, separate anti-sliding pad with leg.

Tripod Using

④ Folding tripod.

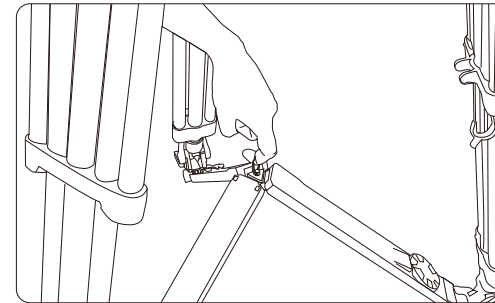

4-1: Loose the locking knobs of each stages and adjust the legs to minium length, then locking all the knobs.

4-2: Adjust the mid-spreader or ground-spreader to minium length, then locking all the knobs.

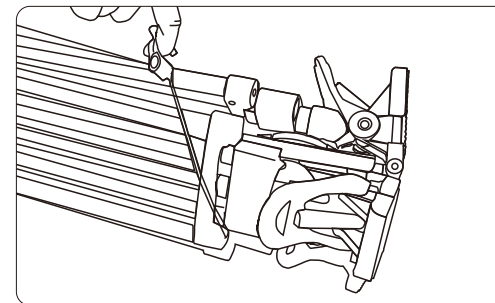

4-3: One hand catch the bowl base, another hand pull the ring of ground spreader and fold it. Then pull out retractable easy hook and wrap around legs and bind them together.

Daily Maintenance

Storage and transport:

When not using the head for a long time, please turn all the knobs to the minimum setting.
When not using the tripod, please avoid storing it vertically to prevent damage.
When not using the tripod or during transportation, please ensure it is stored in the carry bag.

Function inspection:

Please check the tripod payload and the condition of the head locking regularly to avoid accidents.
Please regularly check and adjust the condition of the tripod and head locking to increase the service life.

Function inspection:

1. Use a lint-free cloth to clean the tripods regularly.
2. Please store it in the carrying case, if not used for a long time.
3. Use a semi-stiff brush or a vacuum for cleaning.

Always engage safety locks and devices where applicable on the products.

Don't use the product at temperatures below -30°C or above $+60^{\circ}\text{C}$.
Clean with mild detergent and a soft cloth. Remove dust and sand from all locking threads and sliding segments. Dry the product after use in wet conditions.

IMPORTANT: It is not recommended to use the product in seawater.

If you have any questions during the use of the product, please carefully read the instructions or seek help from your local distributor.

Customer Information

Customer Name	Contact No.
Address	

Sales Manager

Sales Date	Dealer
Dealer Contact No.	

#1 Maintenance Record

Service Date	Signature of Repairman
Cause of Problem	
Service Result:	<input type="checkbox"/> Solved <input type="checkbox"/> Unsolved <input type="checkbox"/> Refunded/ Replaced



EI-7004B User Manual

Super sturdy, designed for heavy duty systems. The 100mm/4 inch wheels can be individually braked.
Folds for transporting.

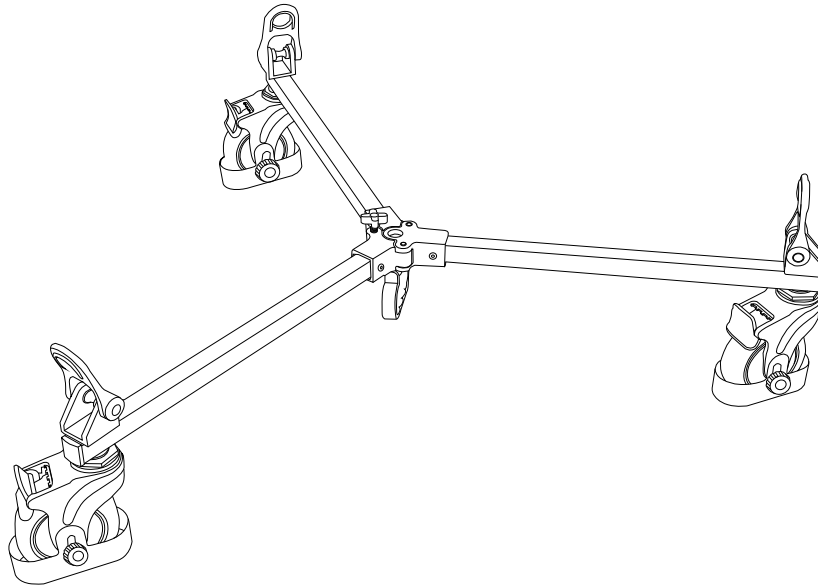

EI-7004B

Model	Net Weight	Safety Payload	Footprint diameter	Casters diameter
EI-7004B	6.8kg / 15.0lbs	100cm / 39.4in	60kg / 132.3lbs	100mm / 4.0in

In The Box

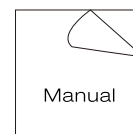
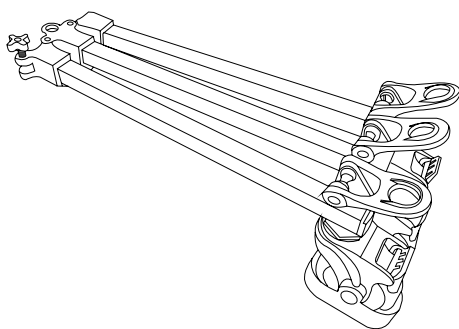

EI-7004B x1

User Guide x1

Contact Information

NINGBO EIMAGE STUDIO EQUIPMENT CO., LTD

Add: NO.373 South Hangyong Road, Luotuo Industry Zone,
Zhenhai, Ningbo, China 315202

Tel: 86-574-55681753/55681675 Fax: 0574-86590078

E-mail: sales@eimagevideo.com

Visit www.eimagevideo.com for more information



EIMAGE official QR code

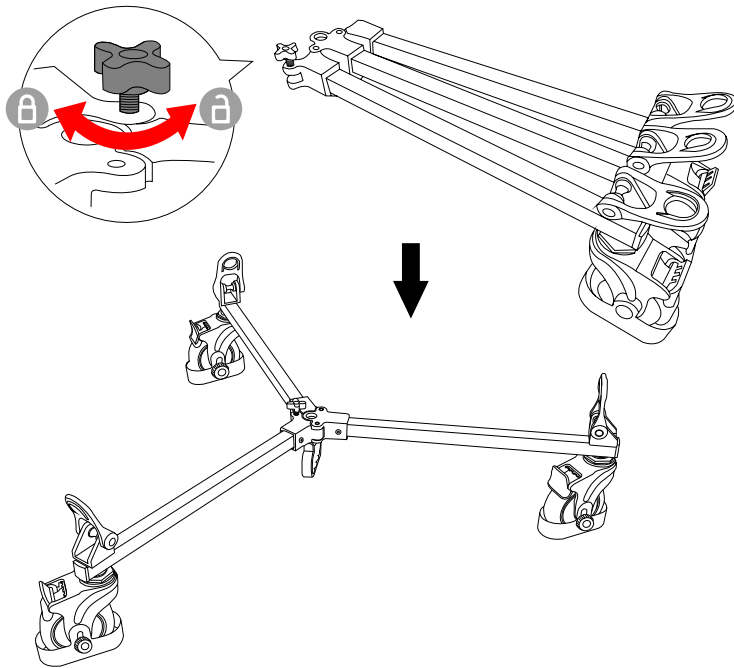

Place the Head into the tripod bowl, then locking the bowl knob, meanwhile using the bubble level to set the head in level (the bulb in the circle), finally lock the bowl knob tightly.

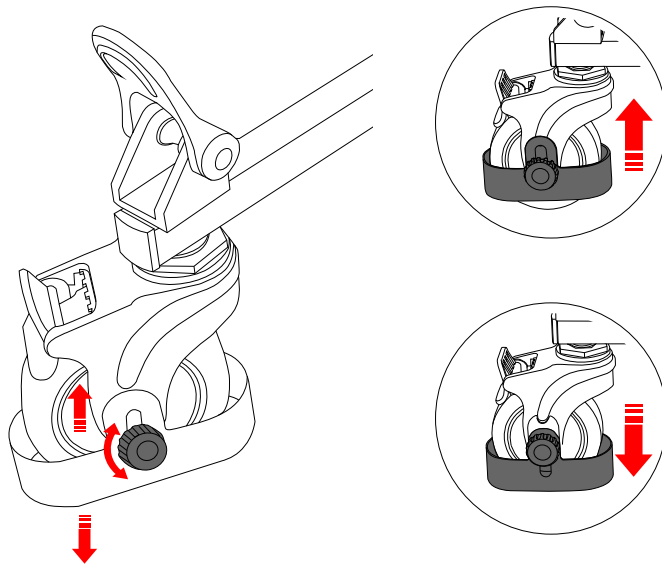

Place the Head into the tripod bowl, then locking the bowl knob, meanwhile using the bubble level to set the head in level (the bulb in the circle), finally lock the bowl knob tightly.

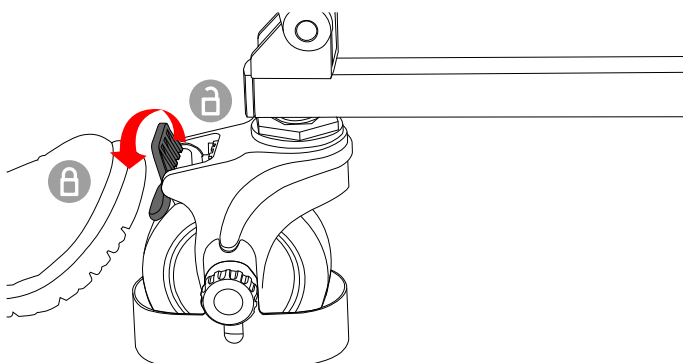

Place the Head into the tripod bowl, then locking the bowl knob, meanwhile using the bubble level to set the head in level (the bulb in the circle), finally lock the bowl knob tightly.