

PT4900-TM-V2



19 in. High Bright Teleprompter w/ Talent Monitor Kit



OVERVIEW

ikan's professional teleprompter series is designed for a quick and easy setup to work efficiently in studio or broadcast applications. The teleprompter includes a 65/35 reflective glass that makes the reflection easier to see for the presenter. The lightweight aluminum teleprompter has multiple 1/4-20" and 3/8-16" threads for mounting to a tripod or pedestal. The monitor includes HDMI, Composite, and VGA video inputs. Its high bright screen ensures clear visibility in any lighting condition. An intuitive image flip button allows for easy adjustment of the display orientation. This teleprompter kit also features a 19" widescreen SDI talent monitor with a built-in tally light.



What's Included

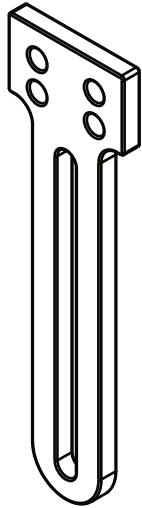

Height Adjustment
Plate

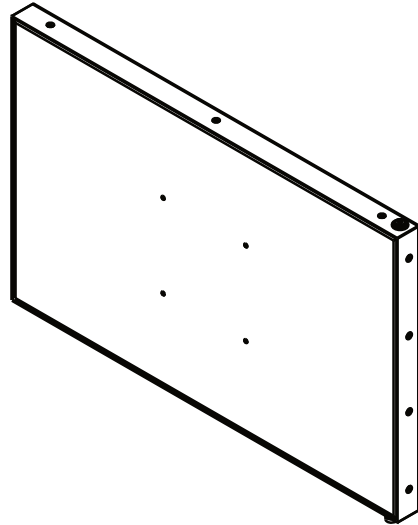

Talent Monitor

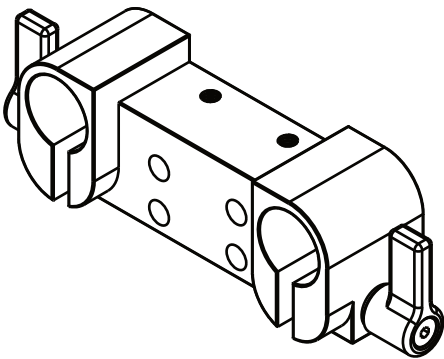

Rod Adapter

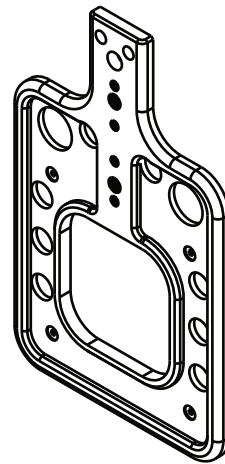

VESA Adapter

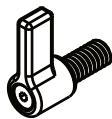

Thumb
Screws



Screws

What's Included

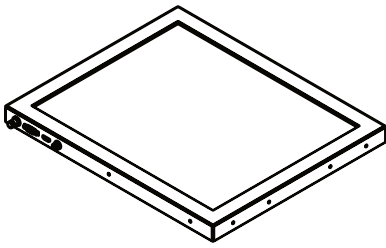

Monitor

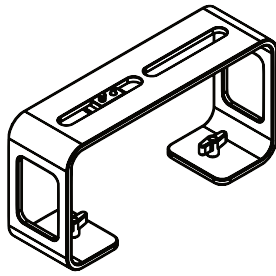

Tall Riser

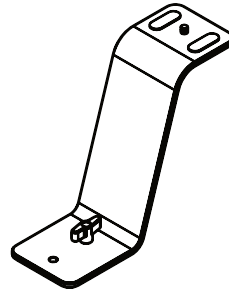

DSLR/Mirrorless Riser

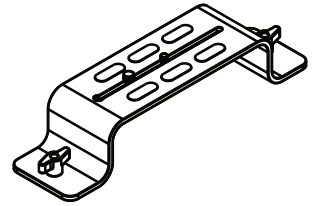

Short Riser

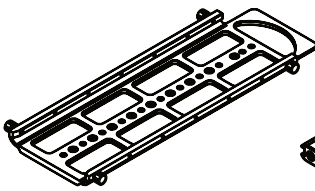

Sled

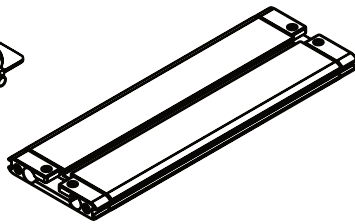

Base

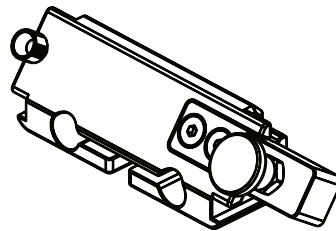

Glass Frame Holder Bracket
w/ Rod Clamps

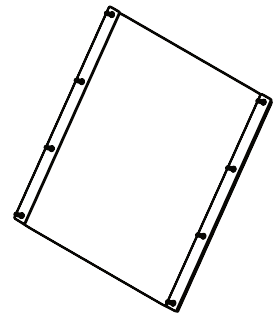

Glass

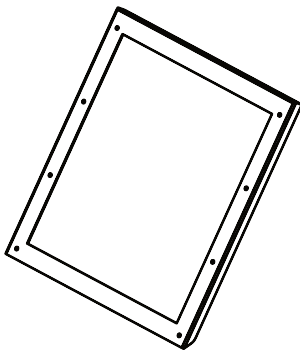

Hood Attachment Frame

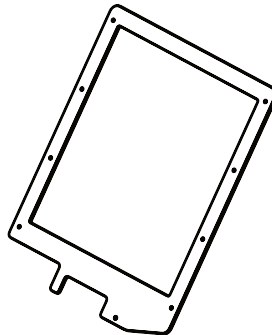

Glass Holder

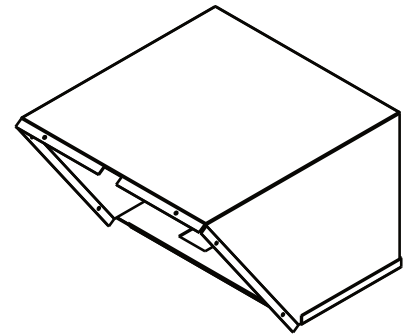

Hood

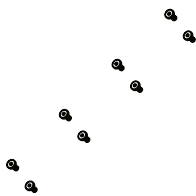

Glass Frame Screws

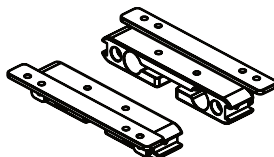

15mm Rod Clamps

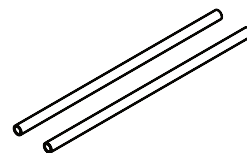

15mm Rods

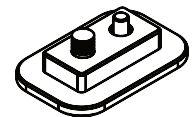

Large Riser
Bracket

Teleprompter Assembly Setup

Step 1

Place the Hood Attachment Frame over the Glass Holder. Then place the glass against the Glass Holder. Make sure the screws pass through the holes on the both the Hood Attachment Frame and the Glass Holder.

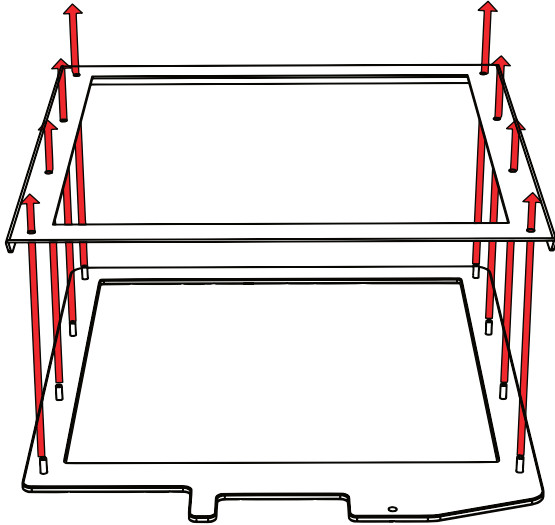

Step 2

Secure the Glass Holder by fastening the knurled nuts to the screws as pictured below.

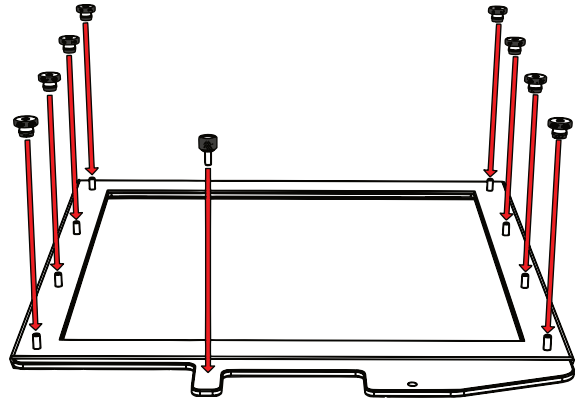

Step 3

Remove the monitor mounts from the teleprompter base using the included larger 4mm hex key to loosen from the 15mm rods.

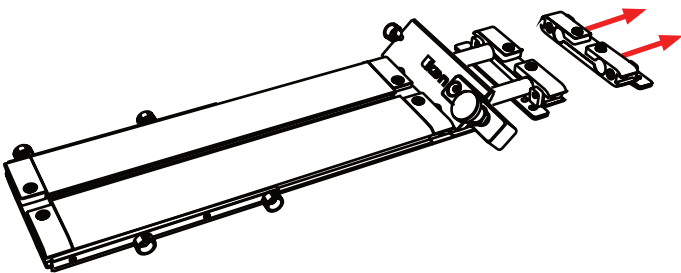

Step 4

Put the washers on before tightening the screws. The washers and 4 additional screws are inside a bag on the bottom foam.

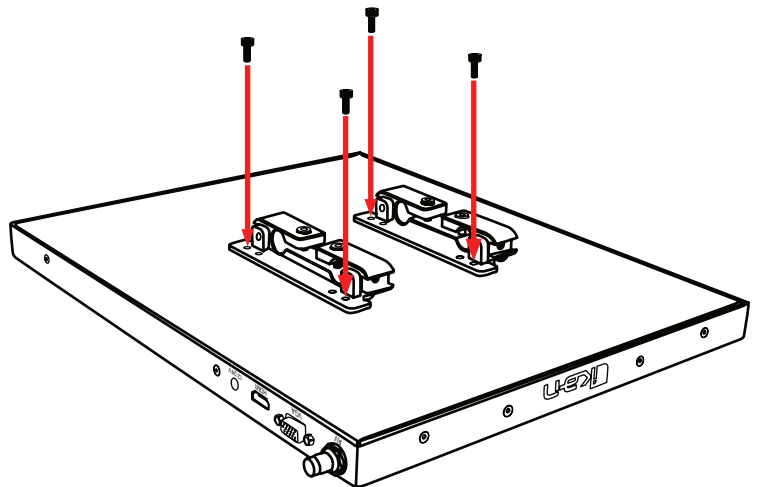

Step 5

After the monitor mounts are attached, adjust the 15mm rods to accommodate the monitor. Leave about 1 inch of room for the teleprompter bracket. Make sure the 15mm rods go through both set of monitor mounts. Please ensure that all screws are properly tightened after inserting the monitor.

SAFETY NOTE Make sure to leave at least 2 inches of the rods inside the teleprompter base.

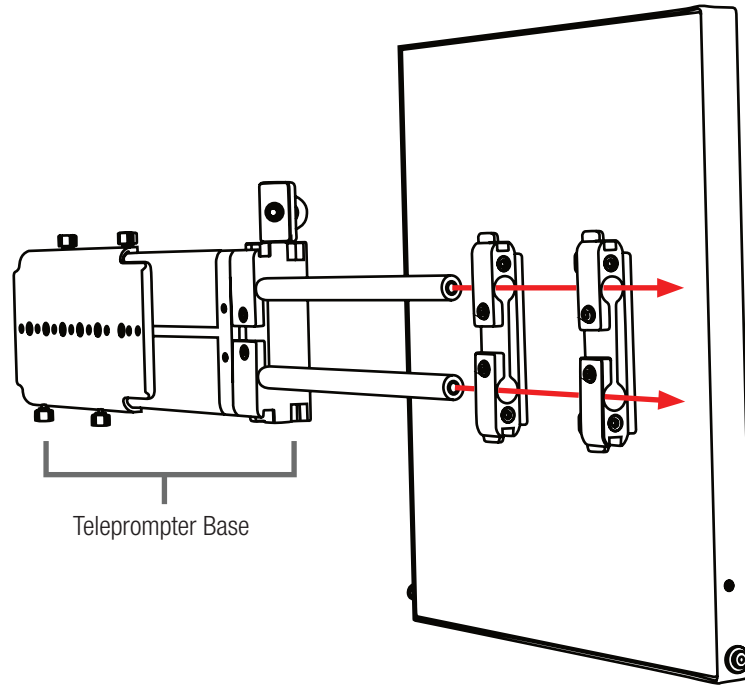

Step 6

While sliding the teleprompter bracket into the slot of the Glass Frame Holder Bracket, pull on the red knob to allow the bracket to fully slide in.

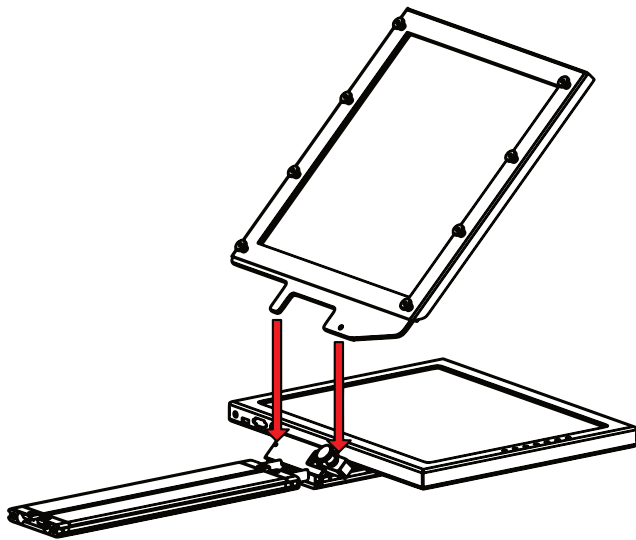

Step 7

Once the bracket is in place, tighten the side screw to lock in place. Double check and make sure all the screws are tightened with the included hex keys.

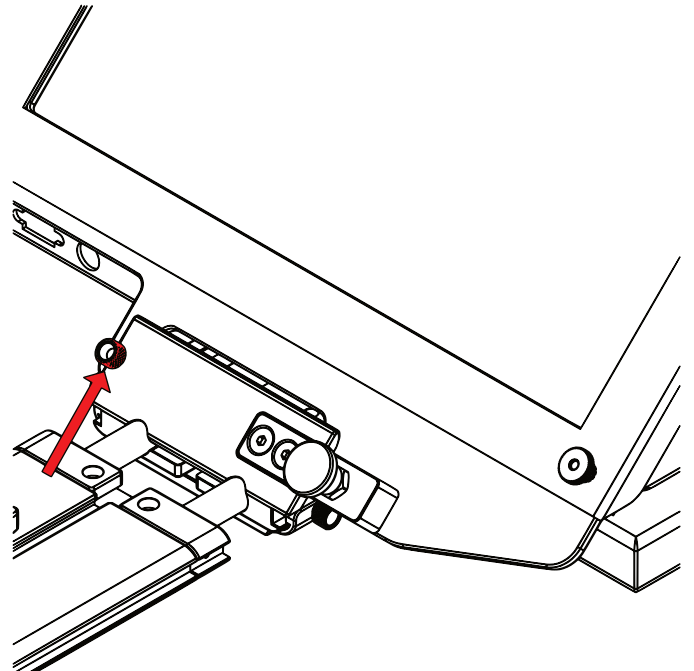

Step 8

Fold the flaps of the Hood alongside the edges of the Hood Attachment Frame. The Hood Attachment Frame includes six threaded clinch studs. Make sure to put the holes on the hood through the threaded clinch studs. The flaps of the Hood are magnetic so they will automatically attach and give extra support.

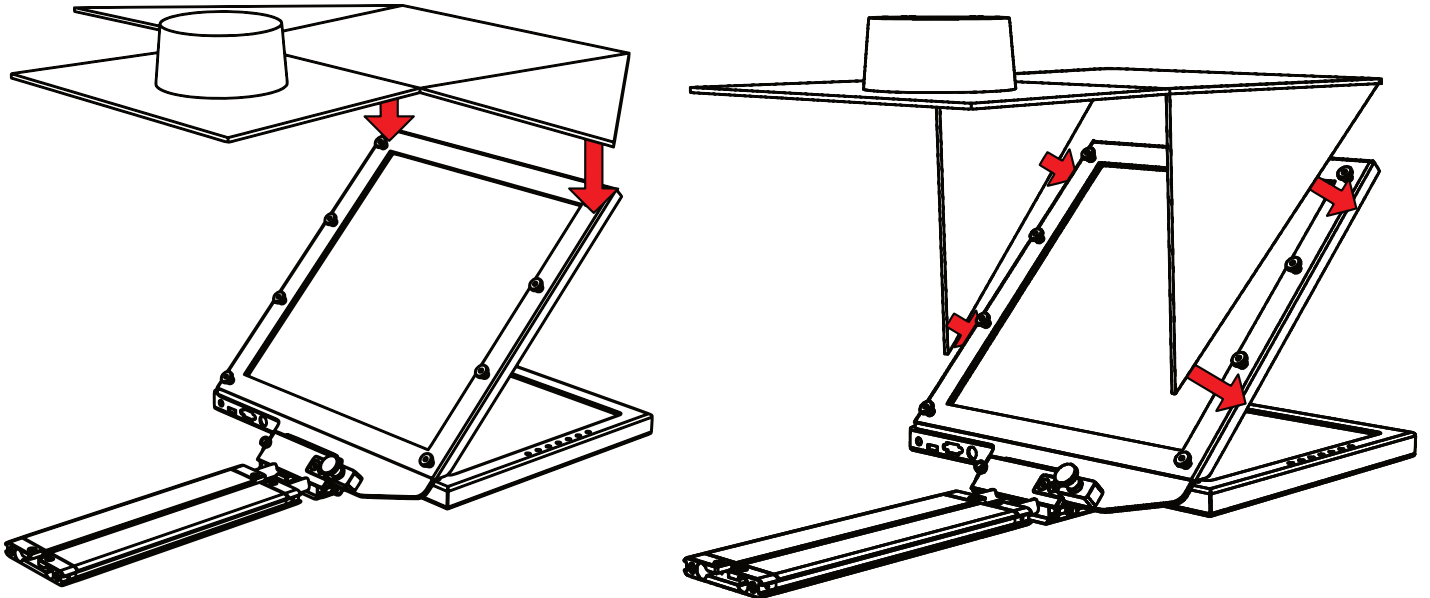

Step 9

To prevent light from leaking through the hood, seal both zippers down.

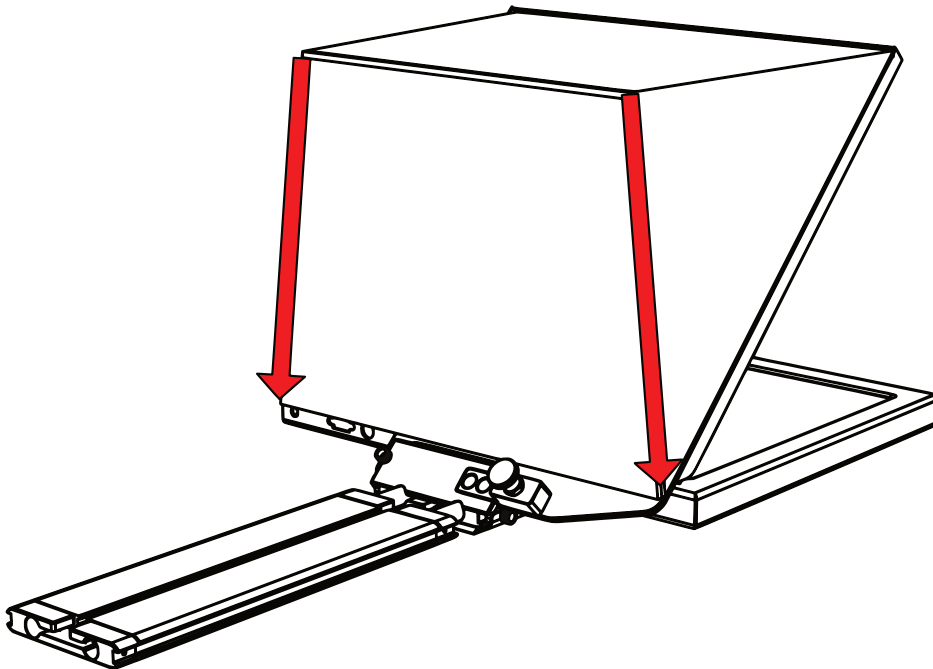

Step 10

Locate the threaded clinch studs on the Hood Attachment Frame and fasten the included nuts to the clinch studs.

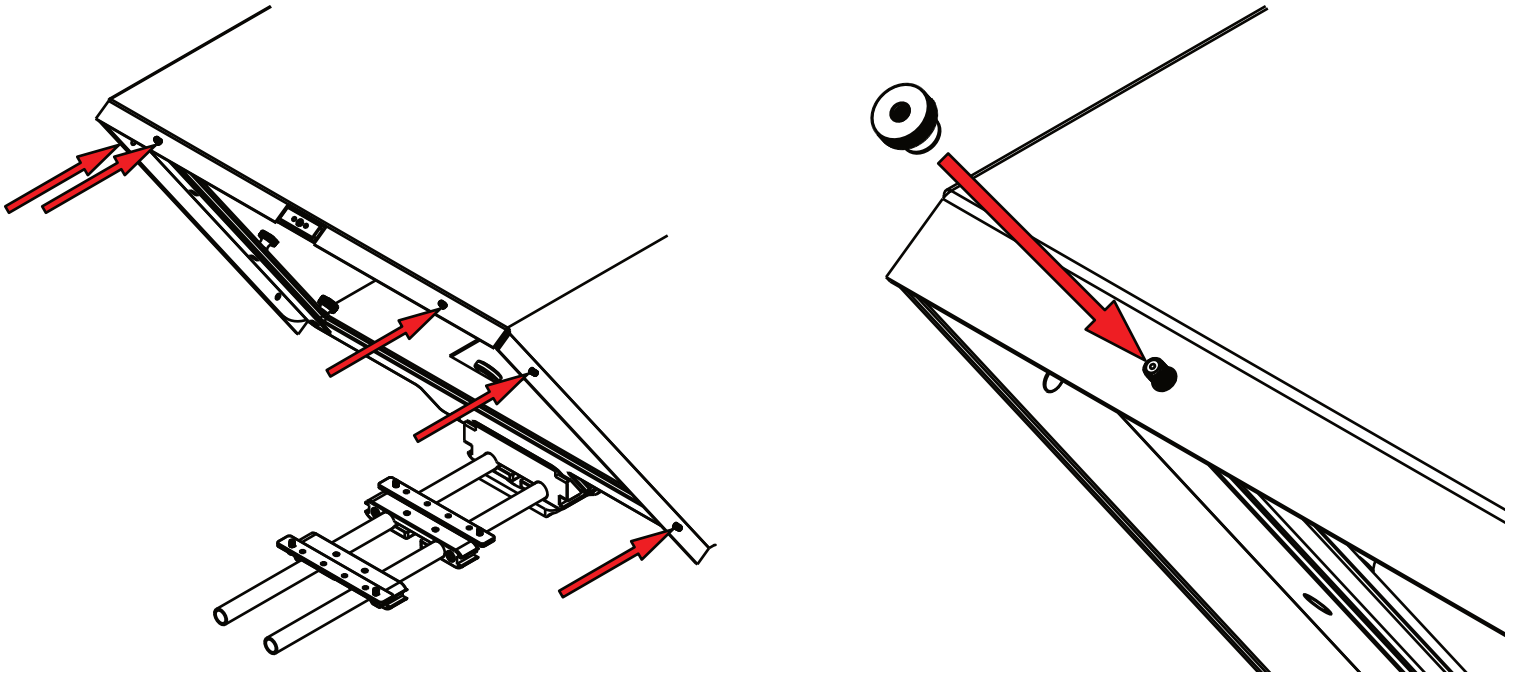

Step 11

Fasten all six of the nuts to the threads on the hood frame to secure the hood to the teleprompter.

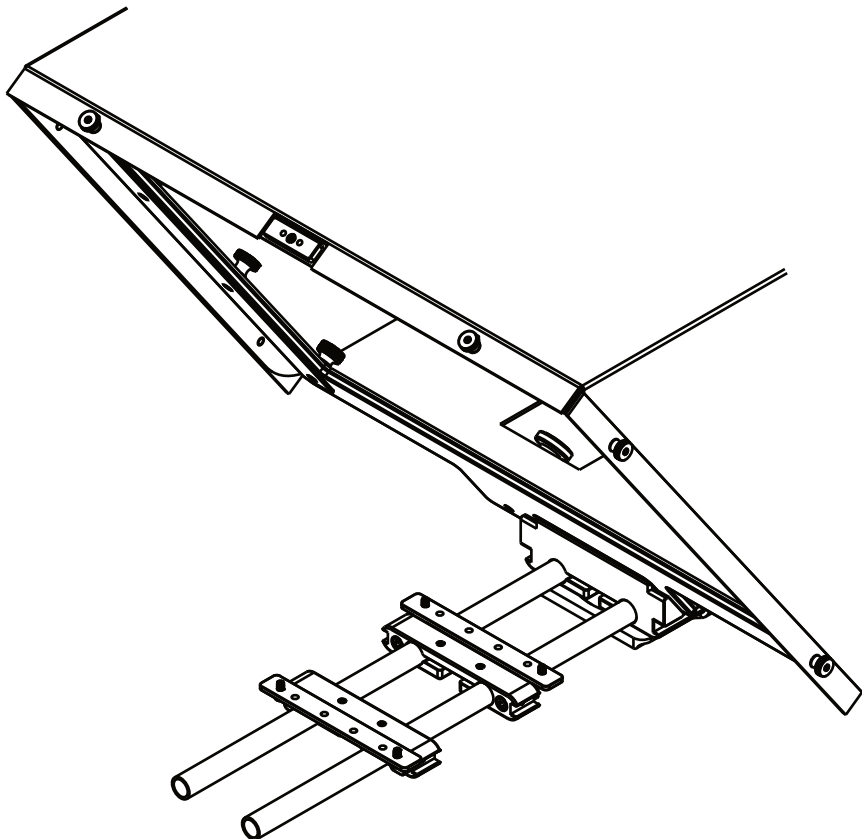

Step 12

If you need to use the Tall Riser Plate, you will need to use the Large Riser Bracket. Insert the Large Riser Bracket through the channel on the Tall Riser Plate. The Large Riser Bracket includes a location pin for use with cameras that feature a location pin hole. If your camera does not feature a location pin, you can remove the location pin by unscrewing it.

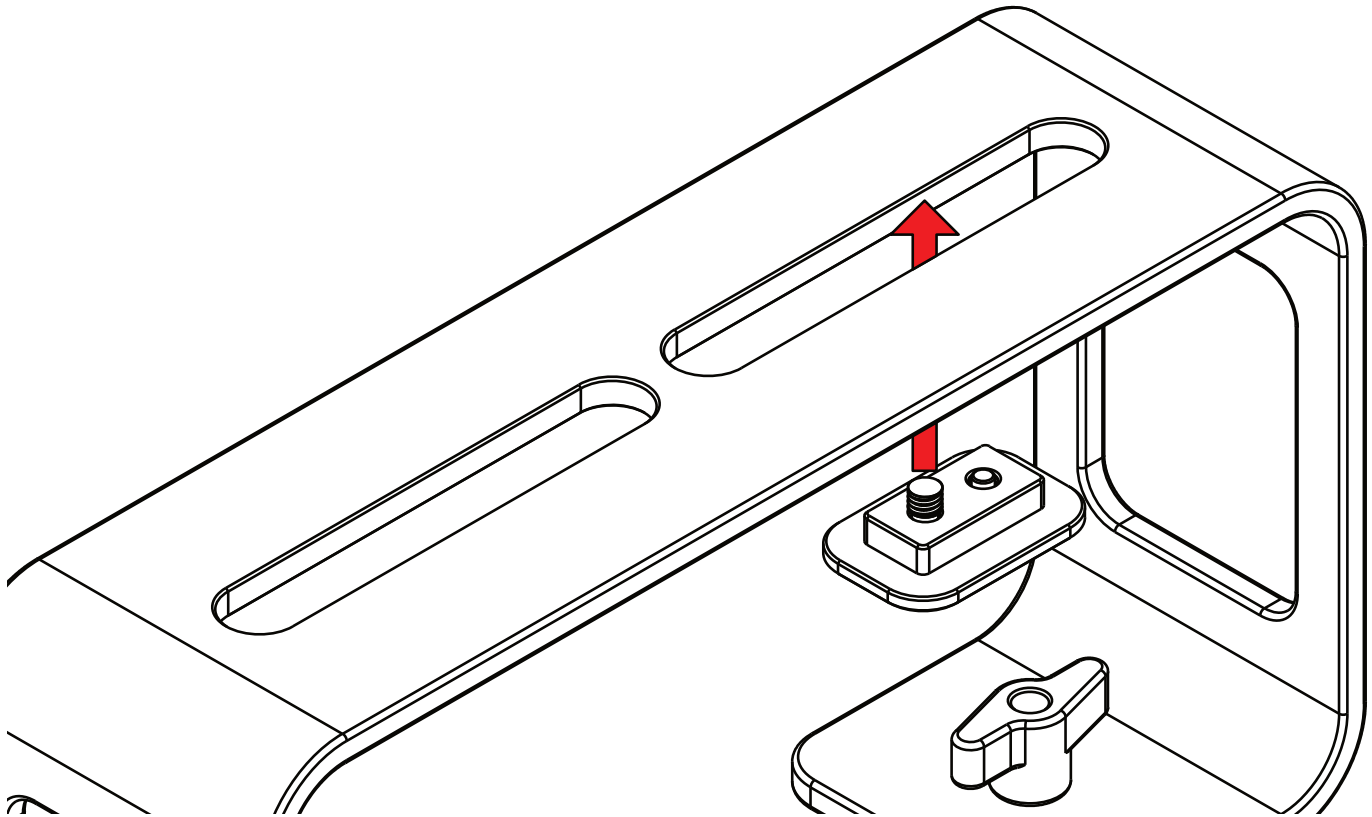

Step 13

Once the Large Riser Bracket is inserted into the channel. Hold it in place and move on to Step 14.

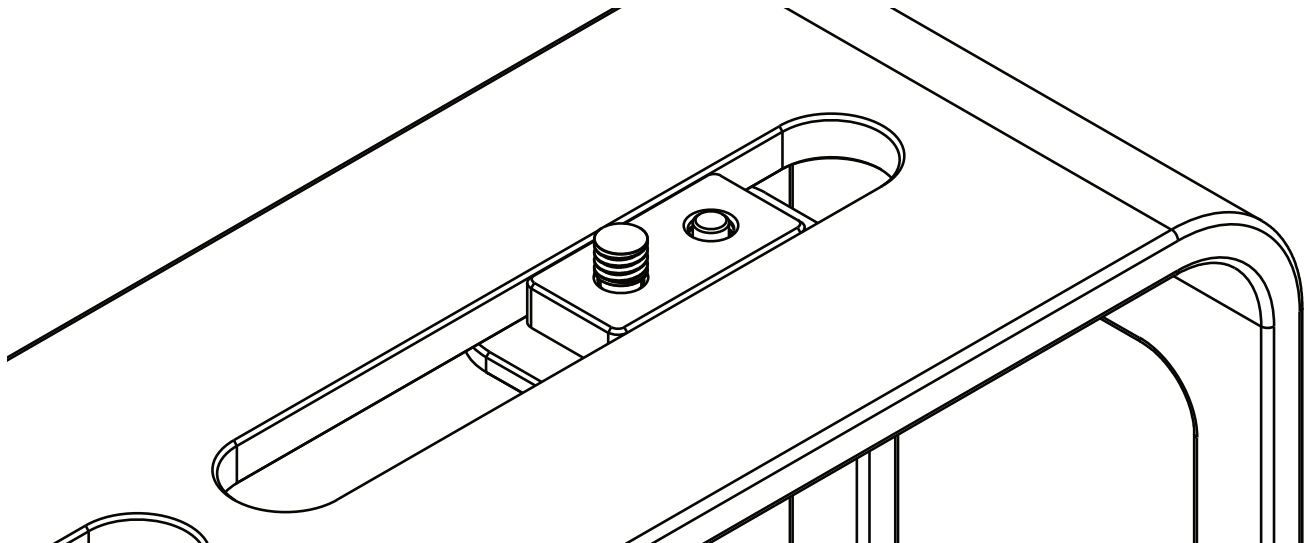

Step 14

Place the riser below your camera and fasten the 1/4-20 camera screw to the bottom of your camera to secure it to the riser plate.

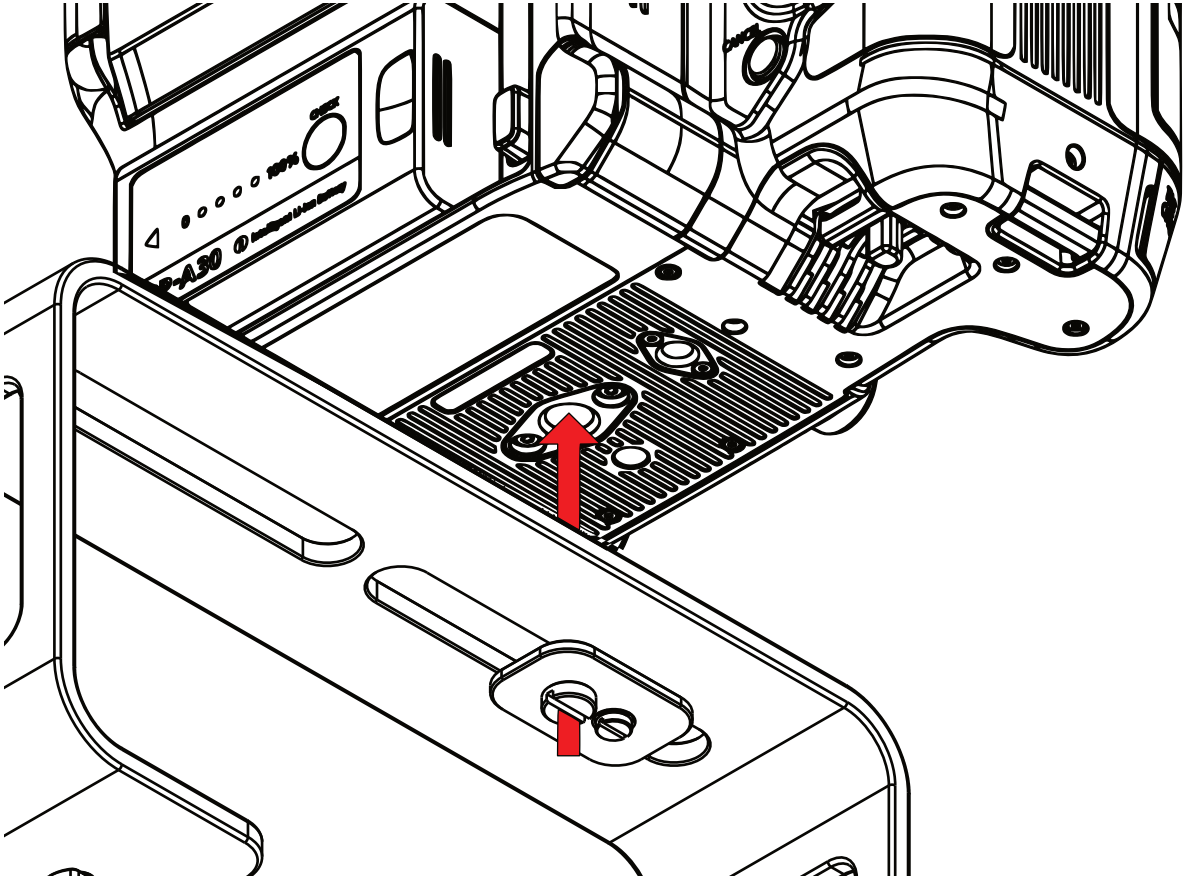

Step 15

Slide the threaded studs into the channel of the base. Make sure they are aligned to the spacing of the holes on the riser plate.

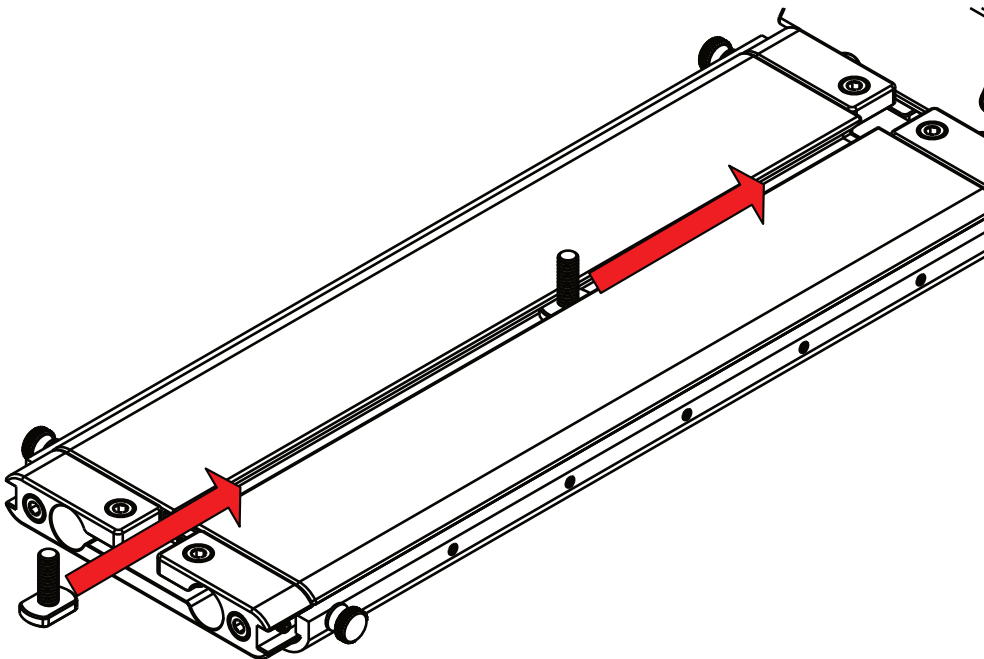

Step 16

Once the threaded studs are aligned to the holes of the riser plate, put the threaded studs through the holes of the riser plate.

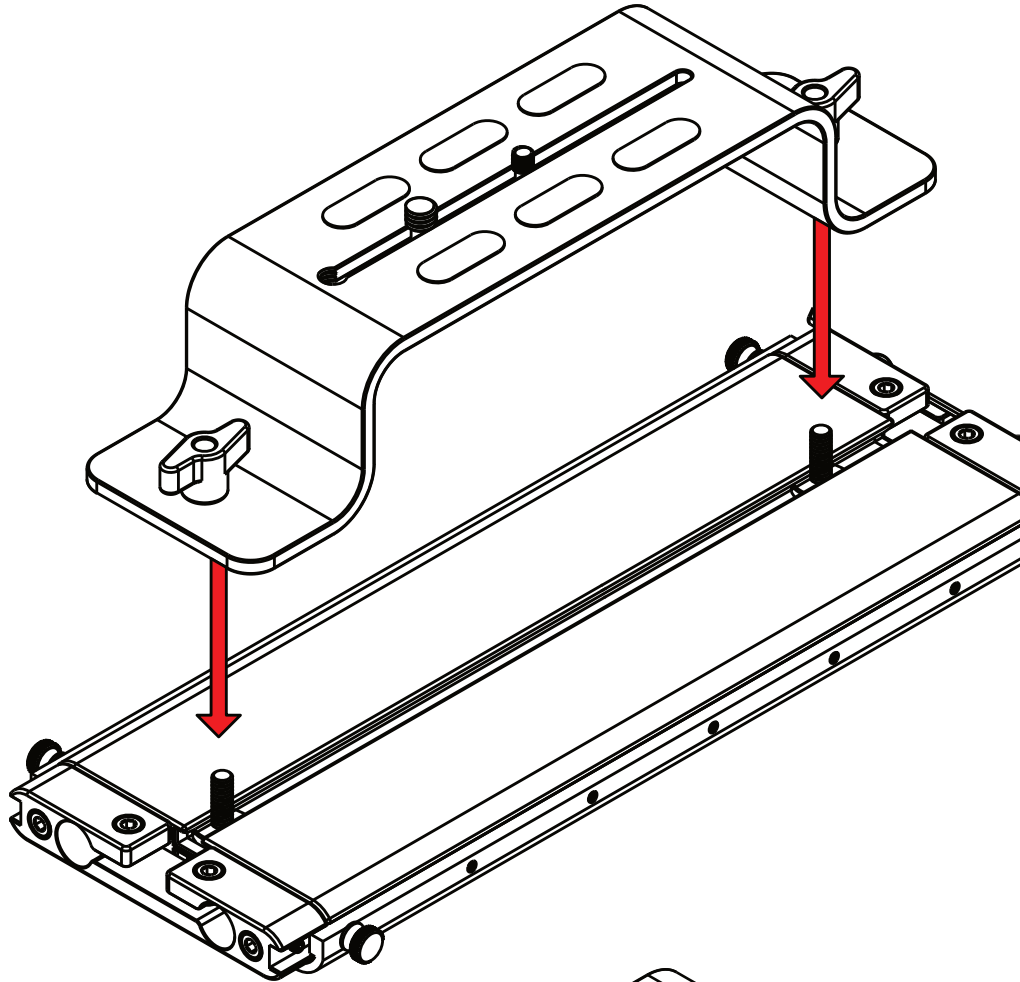

Step 17

Fasten the screws to the threaded studs to secure the riser plate to the base.

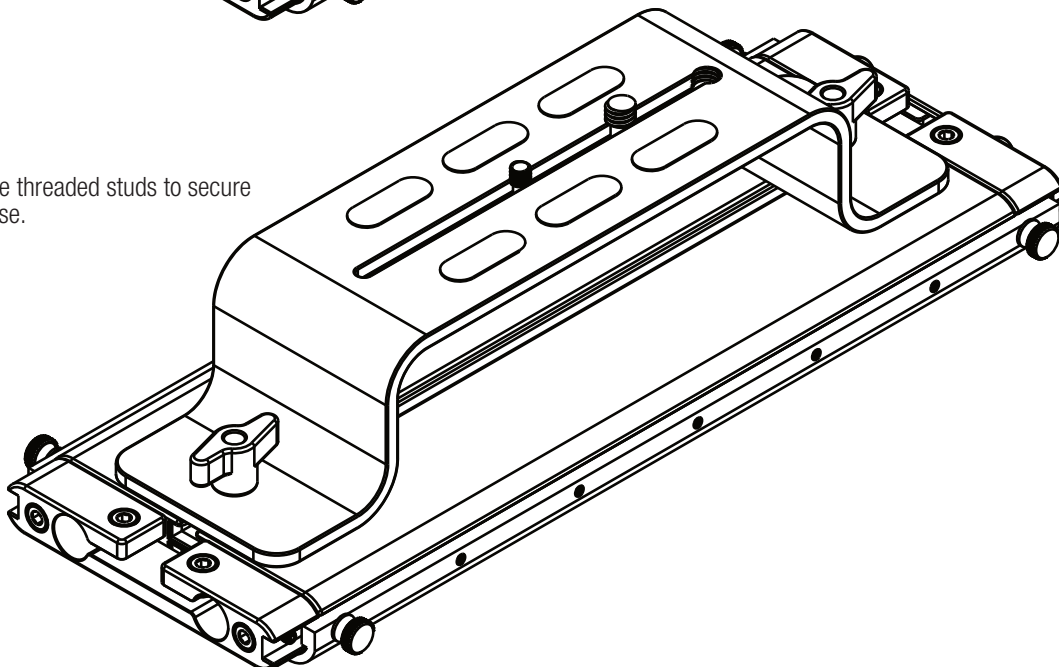

Step 18

Mount your own tripod plate to the sled by aligning the 1/4-20 and/or 3/8-16 screws and fastening them to the Sled. It is recommended that you connect your tripod plate to front of the Sled so that you can balance your teleprompter easier. Once your tripod plate is connected to the Sled, mount the tripod plate to your tripod head.

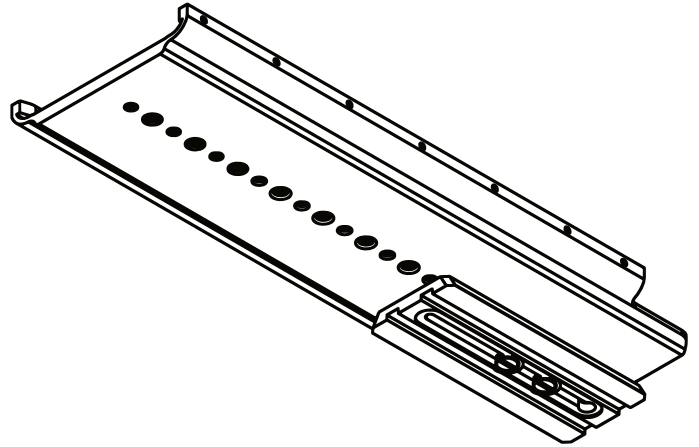
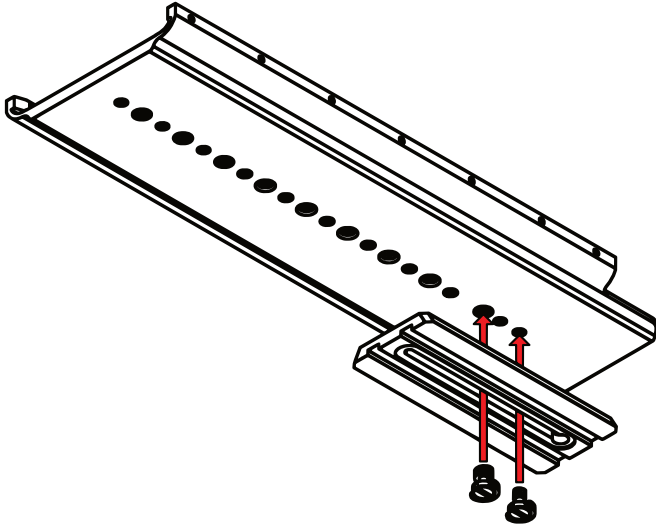

Step 19

Slide the entire teleprompter system into the Sled. Once the teleprompter system is inserted, you can balance it by sliding it along the Sled until the center of gravity is determined.

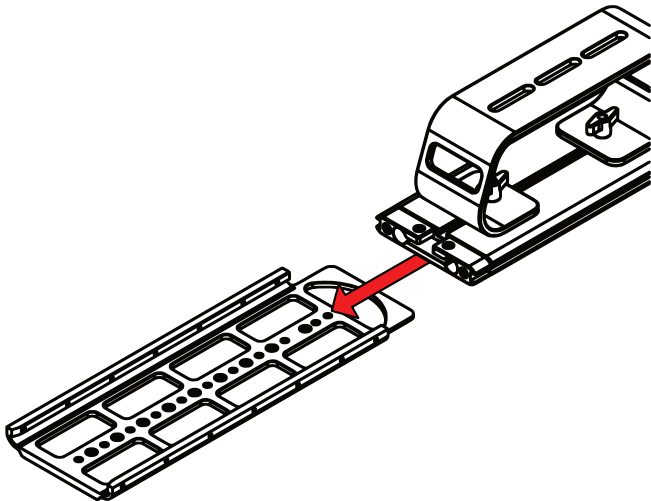

Step 20

Once the center of gravity has been determined, tighten the thumb screws to keep the base from sliding.

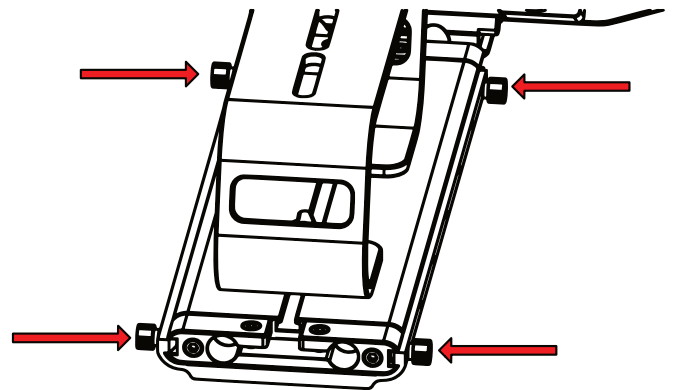

Step 21

To secure your teleprompter system, insert the included headless screws into the threads behind and in front of the Base.

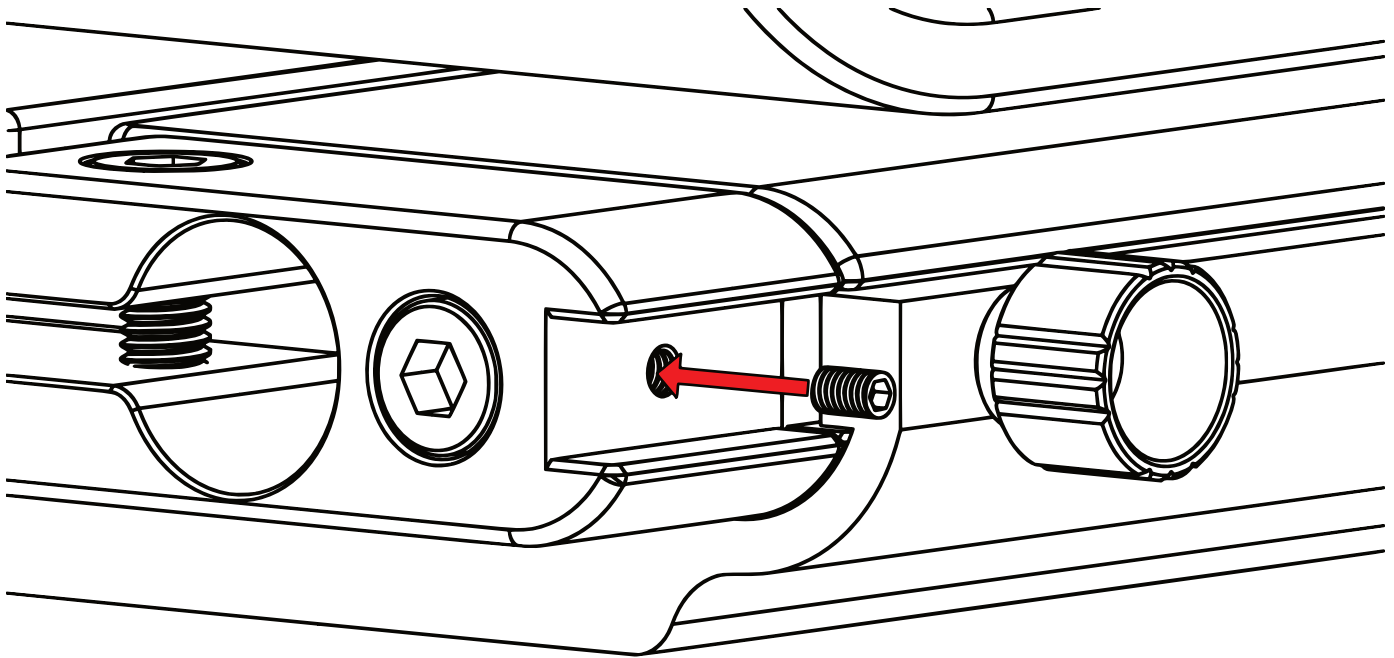

Step 22

The headless screws should be inserted to the threads as pictured below.

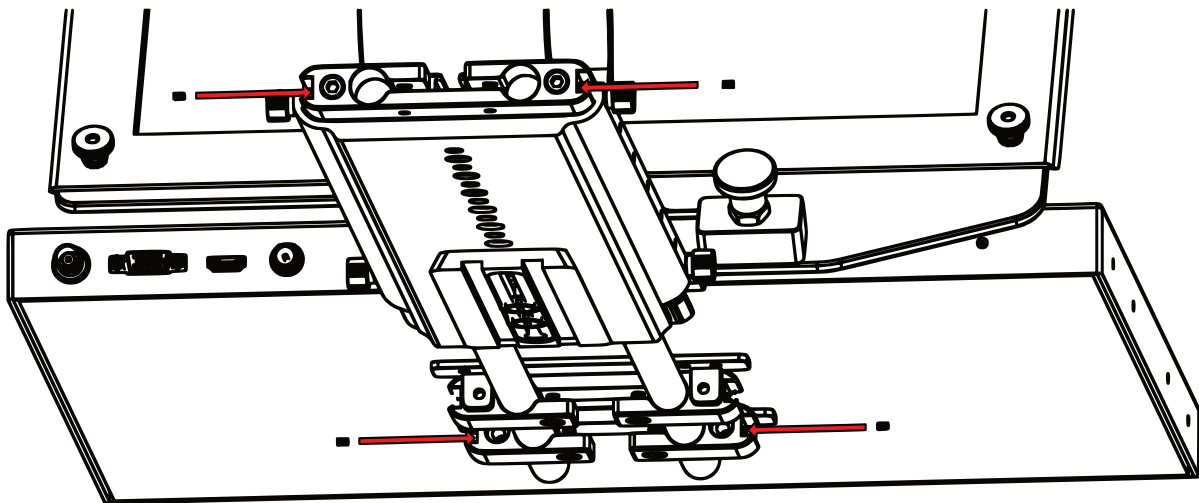

Step 23

Align the holes of the monitor to the VESA Adapter.

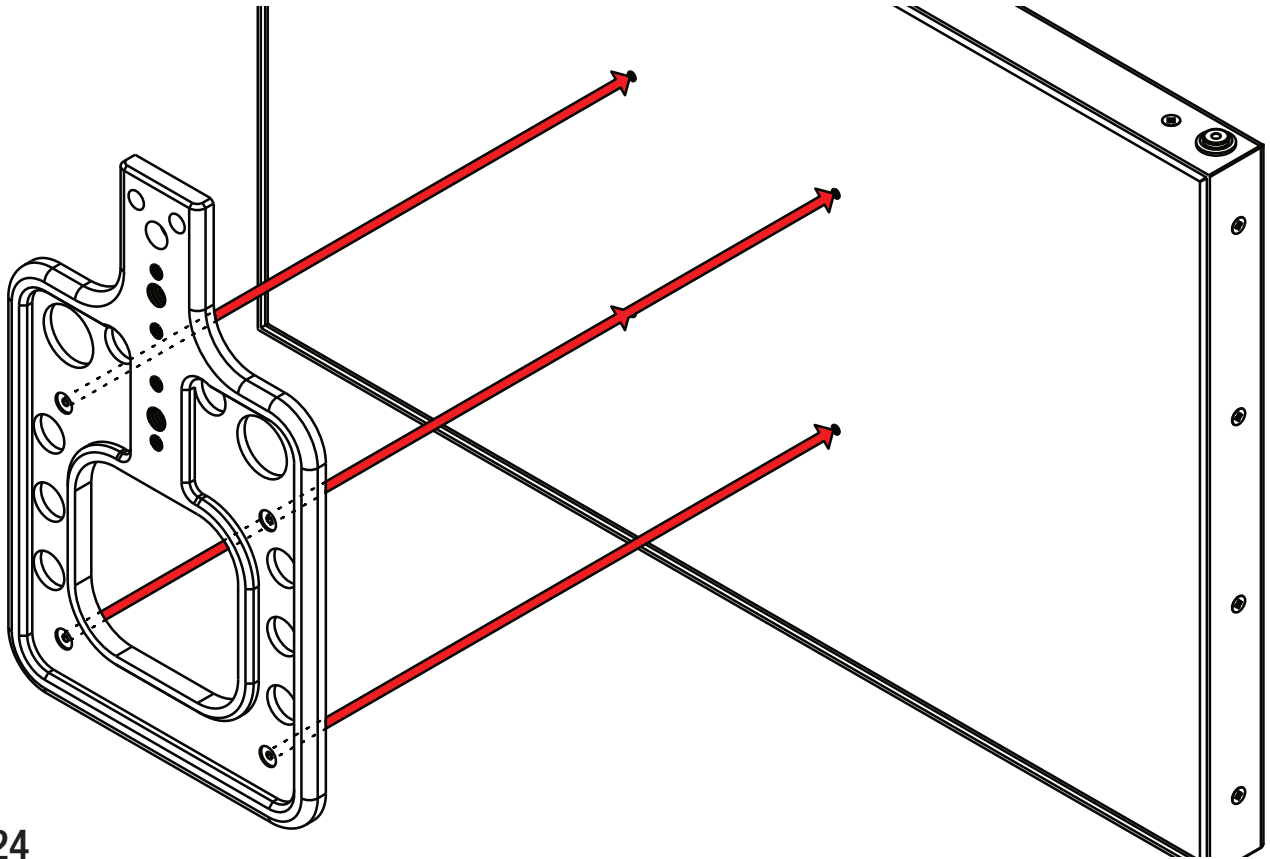

Step 24

Attach the VESA adapter to the monitor by fastening the screws to the monitor

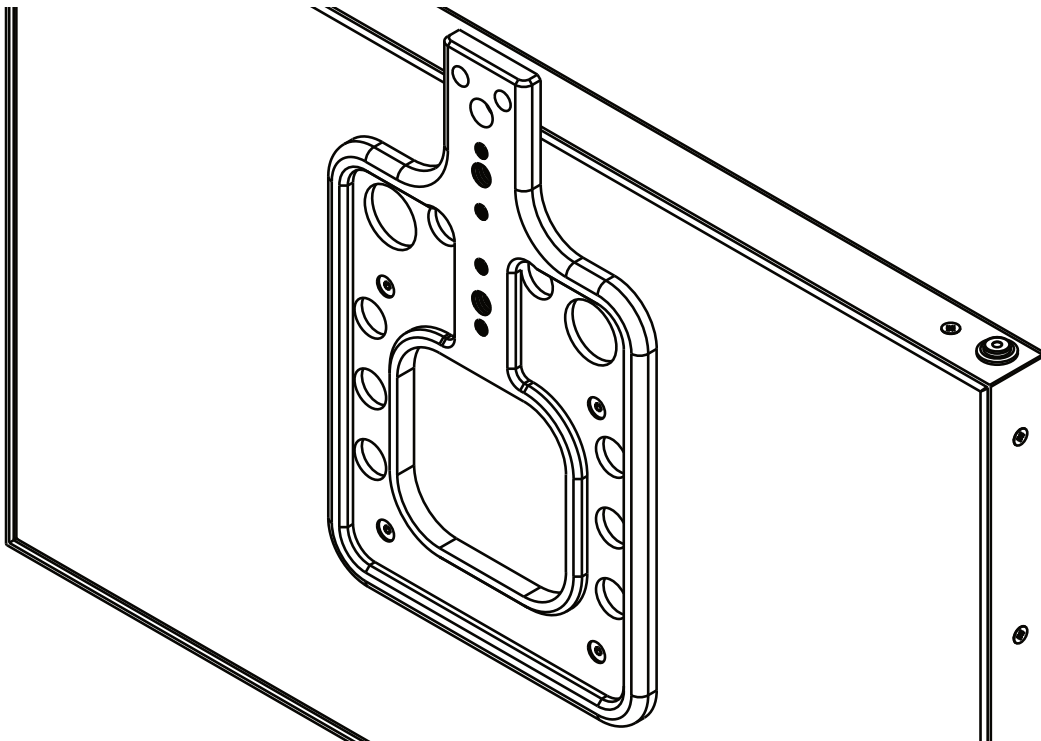

Step 25

Place the Height Adjustment Plate in the Rod Adapter and align the holes.

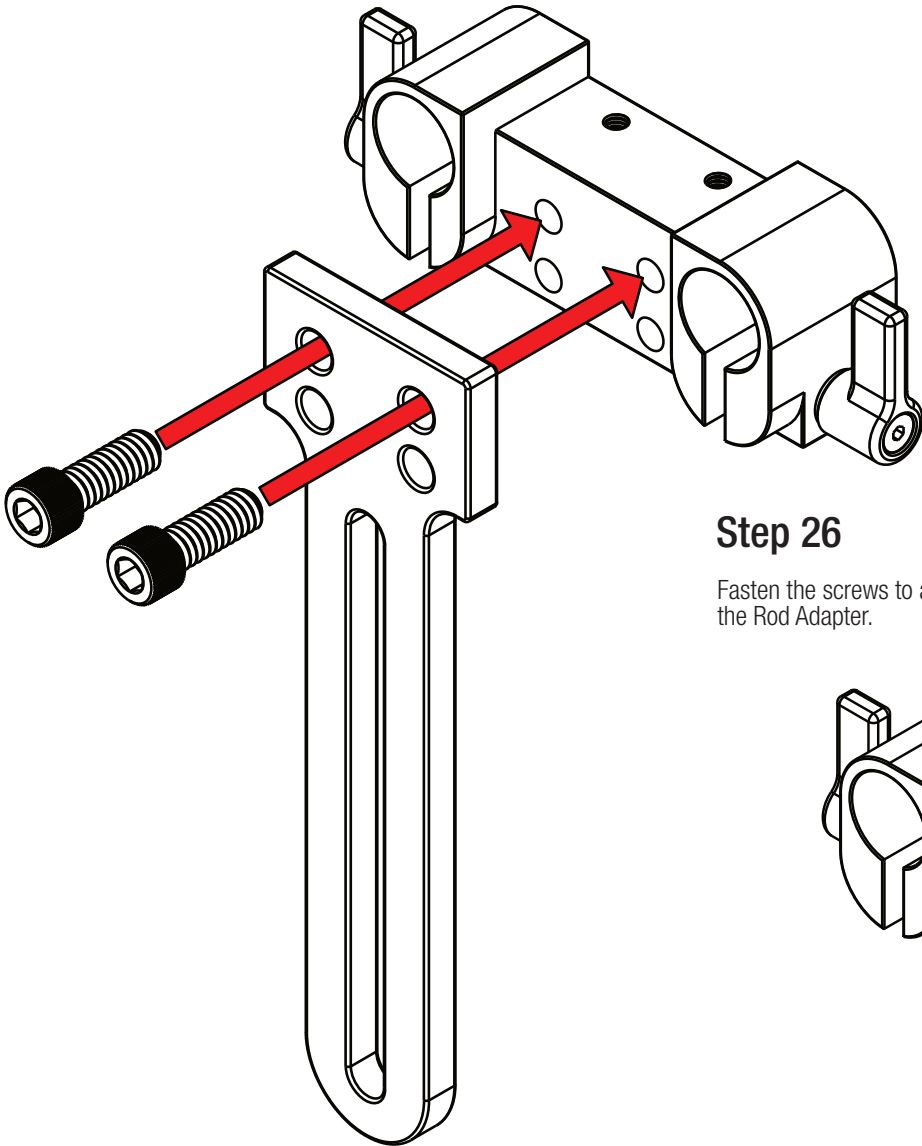

Step 26

Fasten the screws to attach the Height Adjustment Plate and the Rod Adapter.

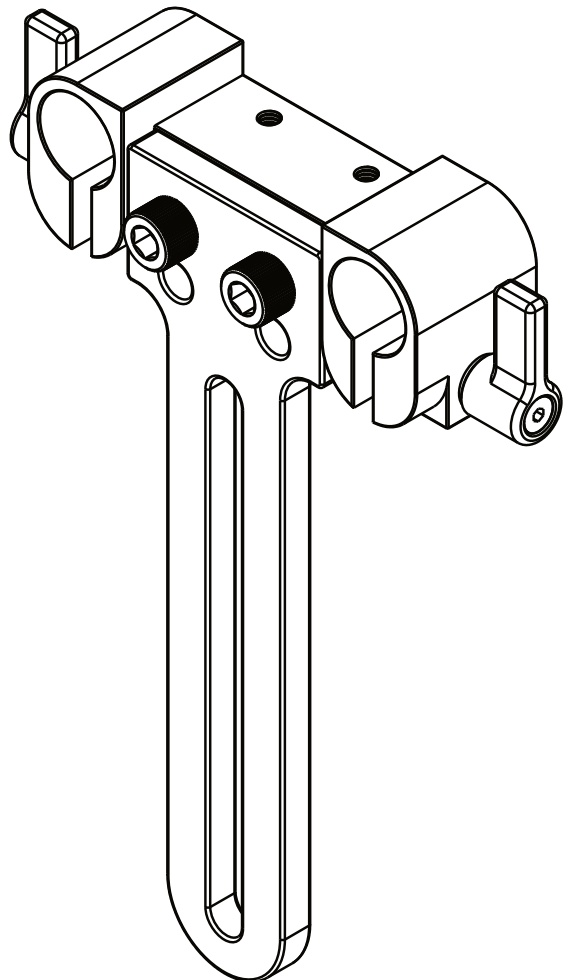

Step 27

Align the threads of the 1/4-20 thumb screw to the threads on the VESA Adapter.

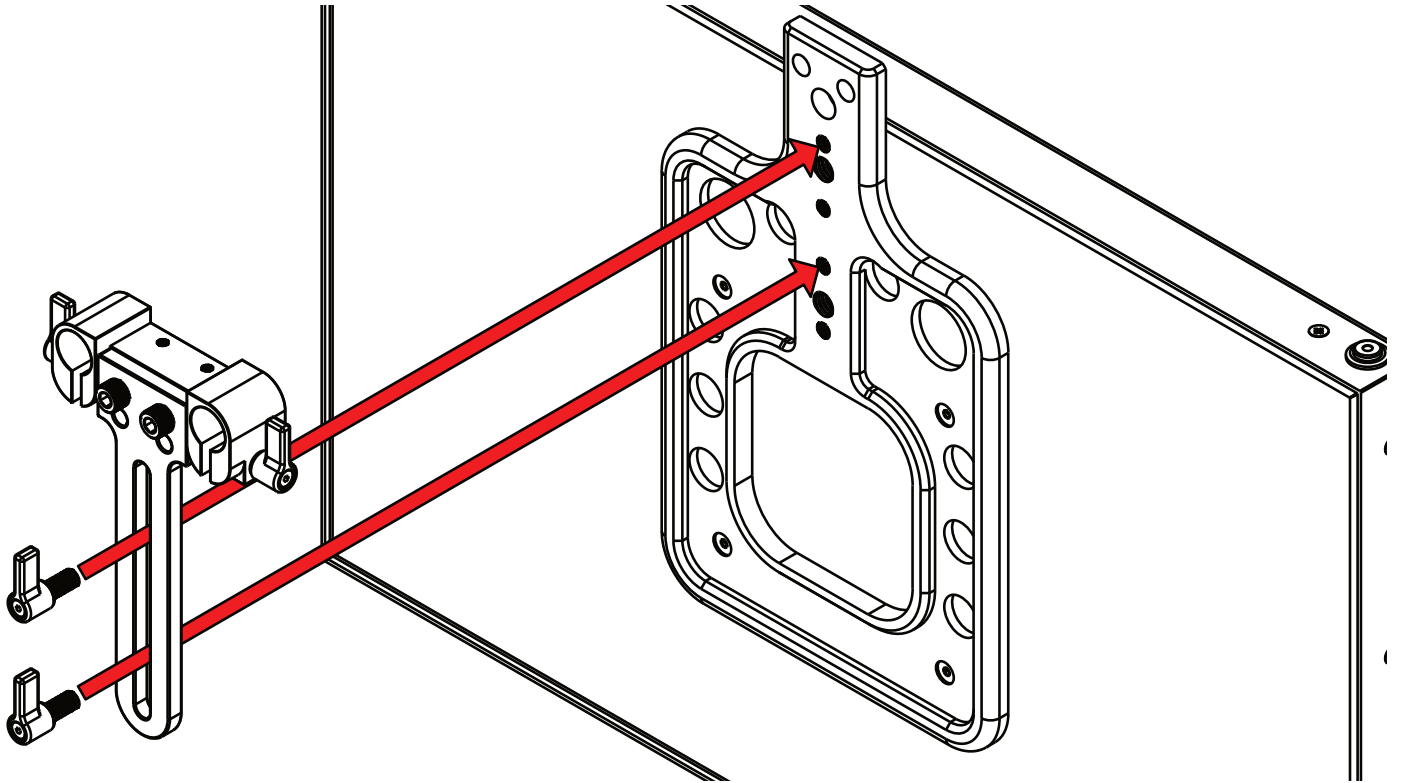

Step 28

Fasten the screws to secure the Talent Monitor to the Rod Adapter.

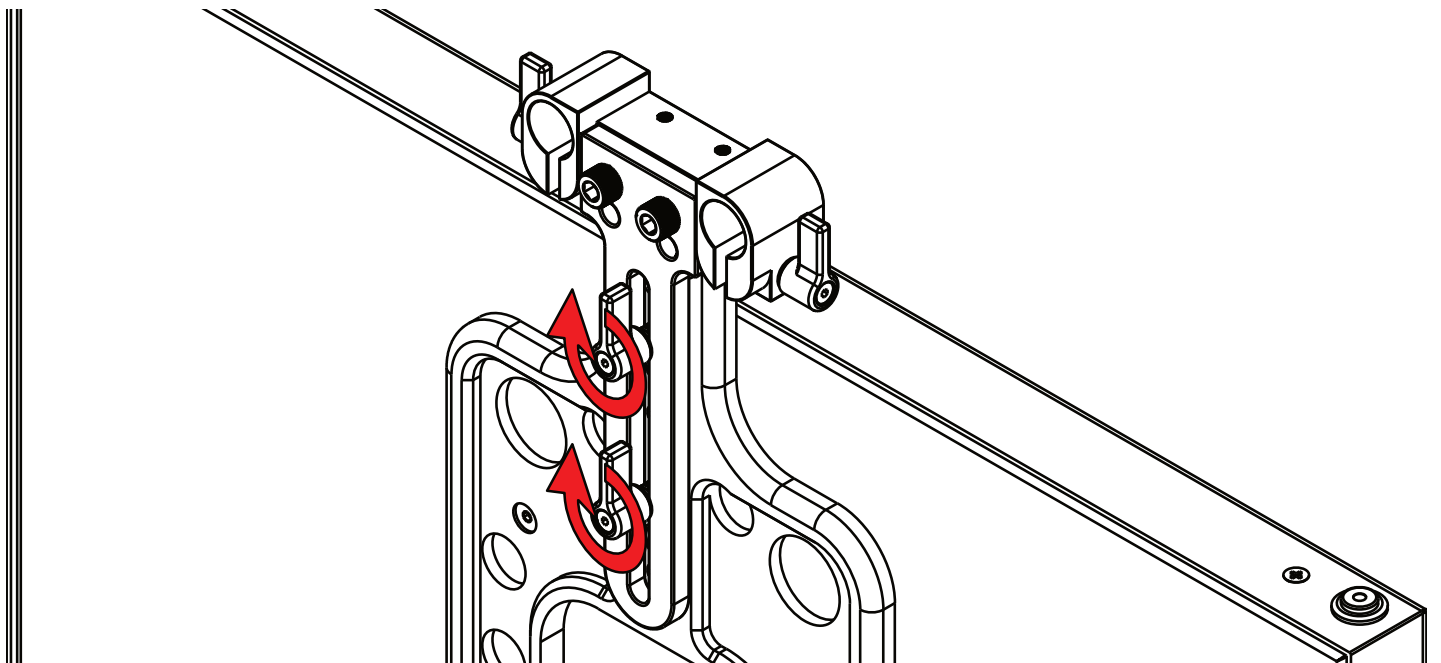

Step 29

Attach the Talent Monitor Mount to the Teleprompter system by inserting the Rod Adapter to the 15mm rods.

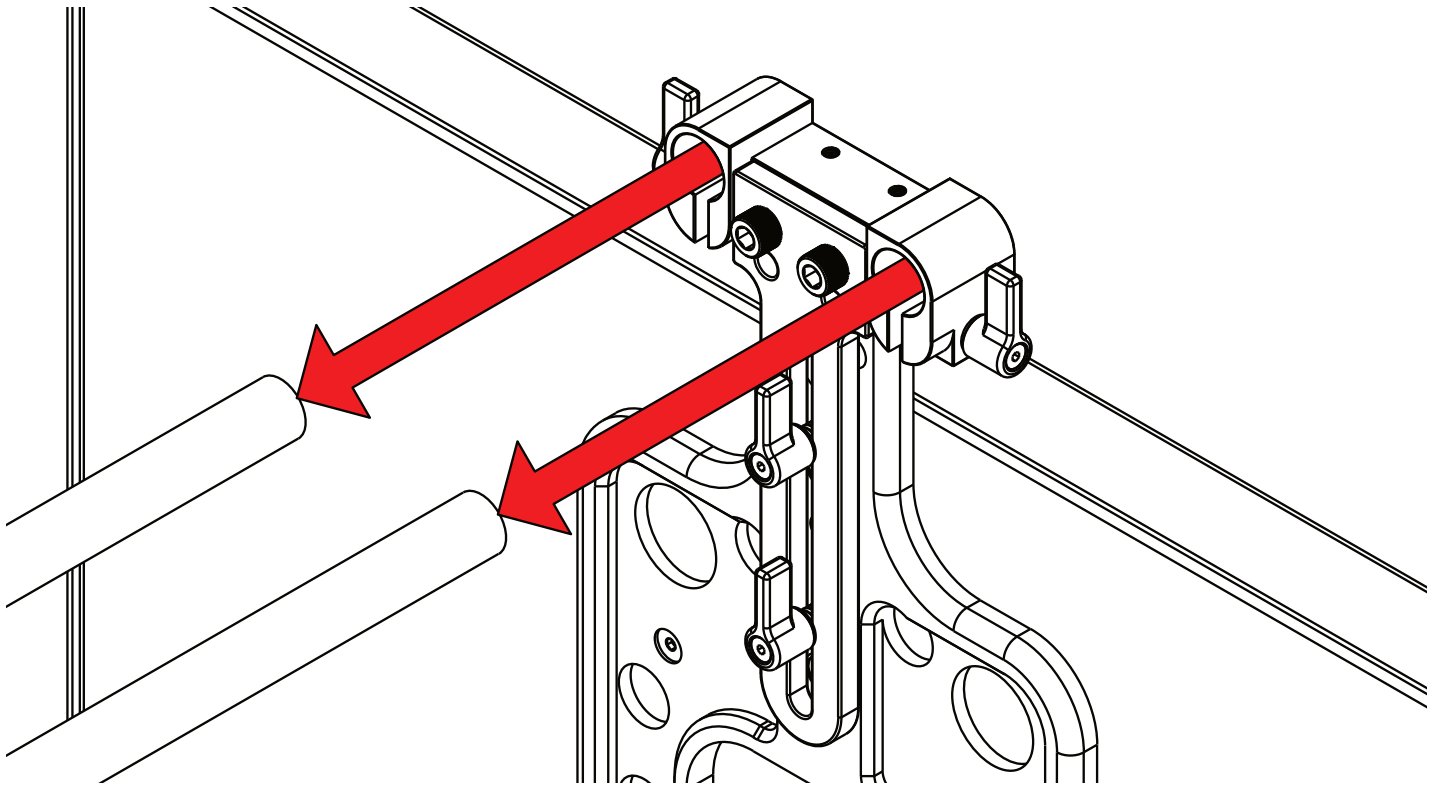

Step 30

Once the Talent Monitor Mount has been inserted to the 15mm rods, secure the Talent Monitor by fastening the thumb screws.

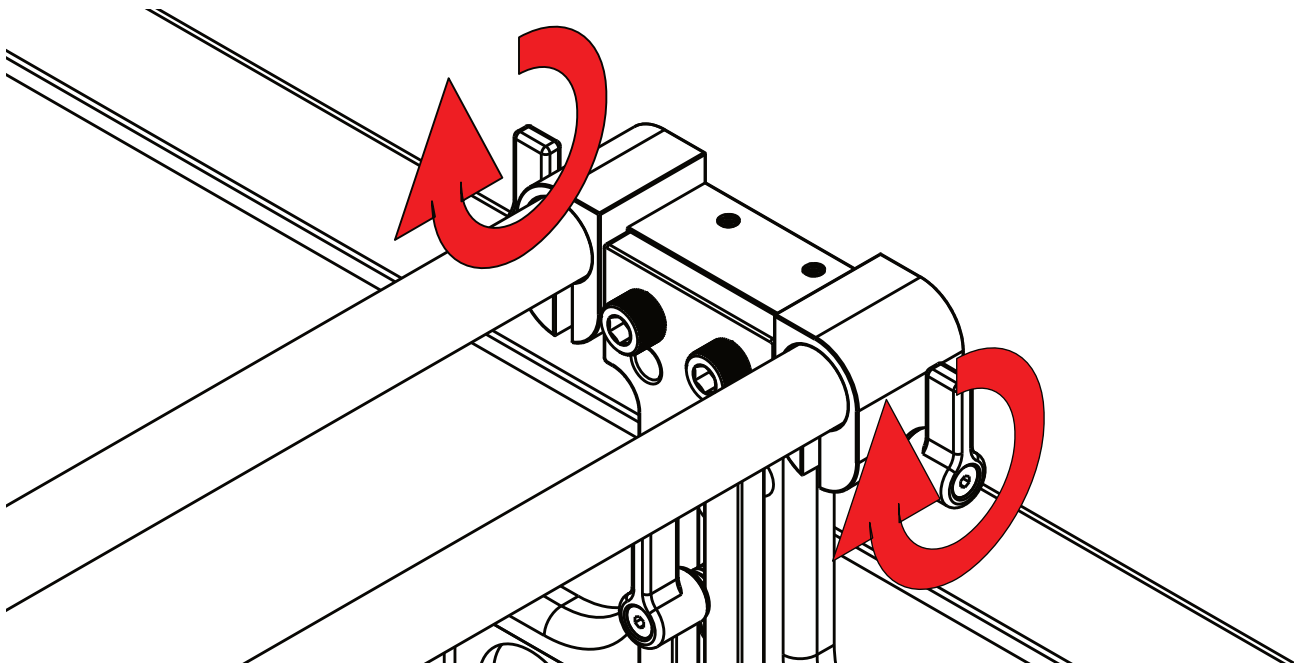

Monitor Ports

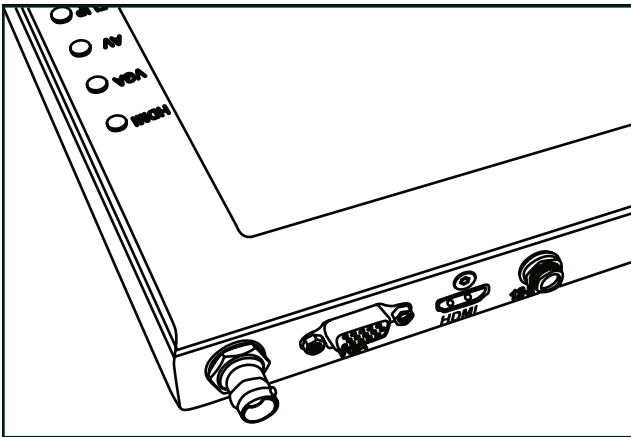

BNC – AV Composite Input
VGA – Video Graphics Array DE15 Connection
HDMI – High-Definition Multimedia Interface Input Connection
Power Port – 12-24v Input

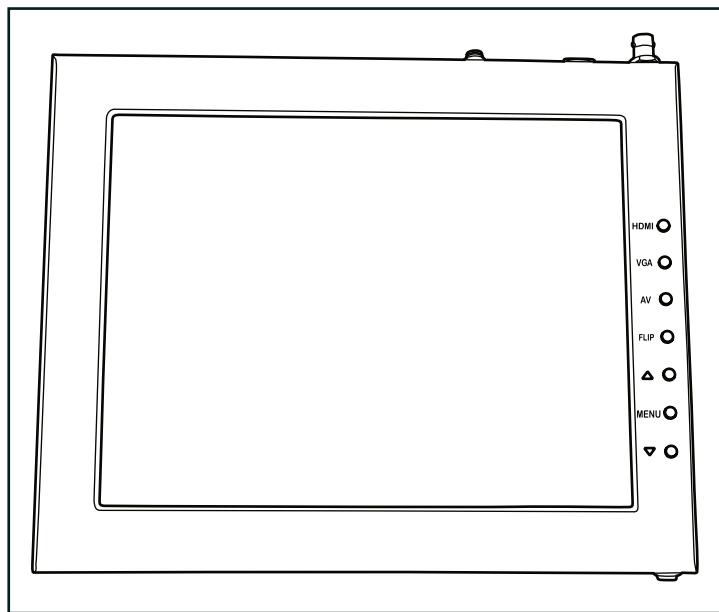

HDMI – Switch HDMI input
VGA – Switch to VGA input
AV – Switch to composite BNC input
Flip – Toggle image flip
(Can be set to horizontal, vertical, or both via menu)
Up Arrow – Toggle up to adjust setting
Menu – Access to monitor settings
Down Arrow – Toggle down to adjust setting

Monitor Menu Settings

Video Config

- Contrast (White Level)
- Brightness (Black Level)
- Tint (Chroma Hue)
- Chroma (Chroma Saturation)
- Sharpness (Detail)
- RGB Setup – Manually configure RGB
- Return

System Config

- Menu Duration – Set duration of how long menu stays on screen
- Video Ratio – Set screen aspect ratio 16:9 or 4:3 (4:3 is native resolution, 16:9 will create black bars)
- Flip-H – Assign toggle button to flip image horizontally
- Flip-V – Assign toggle button to flip image vertically
- Reset – Factory reset
- Return

PC Setup (Only available for VGA)

- H-Position – Adjust horizontal position
- V-Position – Adjust vertical position
- Auto – Monitor automatically adjust position
- Return

Exit

How to set-up FLIP button feature:

1. Press MENU button
2. Navigate to SYSTEM CONFIG.
3. Navigate to FLIP-V or FLIP-H
4. Change FLIP-V and/or FLIP-H to "ON"
5. Exit MENU
6. The FLIP button should now be activated and can be pressed to mirror the image Horizontally or Vertically
7. When FLIP-H is ON, the image will flip Horizontally
8. When FLIP-V is ON, the image will flip Vertically
9. If both are ON, the FLIP button will toggle both Horizontal and Vertical flip

Watch our VIDEO TUTORIAL on how to assemble PT4900-V2 Teleprompters:

<https://ikancorp.com/pt4900-v2-tutorial-videos/>



Specifications

PT4900-V2

19 in. Teleprompter

Riser Plate Height	Short: 2.06 in./52.5mm Tall: 5.31 in. /135mm DSLR: 6.29 in./160mm
Length of Rods	15mm x 400mm
Build Material	Chassis: Anodized Aluminum Rods: Carbon Fiber
Reading Range	25 ft. / 7.62 m
Beamsplitter Ratio	65/35
Beamsplitter Shape	Rectangular
Beamsplitter Material	Glass
Tripod Mounts	11 x 1/4 in. -20 Female 9 x 3/8 in. -16 Female
Product Weight w/ Low Plate	29.6 lbs.
Product Weight w/ Medium Plate	30 lbs.
Product Weight w/ High Plate	30.13 lbs.
Product Weight w/ DSLR Plate	29.5 lbs.
Height of Teleprompter	16.1 in./ 411mm

19 in. Teleprompter Monitor

Aspect Ratio	4:3
Maximum Brightness	1000 cd/m2
Screen Size (Diagonal)	19 in.
Mount	VESA 100mm
Video Inputs	AV COMPOSITE, HDMI, VGA
Input Voltage	DC 12v / 4A
Power Consumption	21W
Product Weight	6 lbs.
Product Dimensions	17 in. x 15 in. x 1 in.
Native Resolution	1280 x 1024
Viewing Angle	160° (H) / 170° (V)
Build Material	Aluminum Chassis
Image Flip	Horizontal: Yes Vertical: Yes

Optional Accessories

PT4U-G	Replacement Glass for PT4900-V2
M19W-V2	19" Talent Monitor Add On Kit for PT4900-V2
PT-PEDAL	Teleprompter Foot Control Pedal
PT-CONTROLLER	Teleprompter Rotary Controller
PT-CASE-4U	Rolling Hard Case for PT4900 Teleprompter



Foam Case

To make your teleprompter more portable, we packed it in a reusable, high-quality foam. The shape and size of the foam was designed to fit into Ikan's PT-CASE-V2.



****DO NOT THROW AWAY FOAM CASE****

Learn More

More dynamic information at official website: www.ikancorp.com

Support

Contact email: support@ikancorp.com

CONDITIONS OF WARRANTY SERVICE

- Free service for one year from the day of purchase if the problem is caused by manufacturing errors.
- The components and maintenance service fee will be charged if the warranty period is expired.

Free Service will not be Provided in the Following Situations: (*Even if the product is still within the warranty period.)

- Damage caused by abuse or misuse, dismantling, or changes to the product not made by the company.
- Damage caused by natural disaster, abnormal voltage, and environmental factors, etc.

©2024 Ikan International. All rights reserved.



SUPPORT YOUR IMAGE

NINGBO EIMAGE STUDIO EQUIPMENT CO., LTD

Add: No.1230 South Cihai Rd, Luotuo Industry zone, Zhenhai,
Ningbo, China. 315202

Tel: +86-574-86590031/86590061

E-mail: sales@eimagevideo.com

Visit www.eimagevideo.com for more information



E-IMAGE
Official QR Code



Pedestal

EP880S
EP880SK

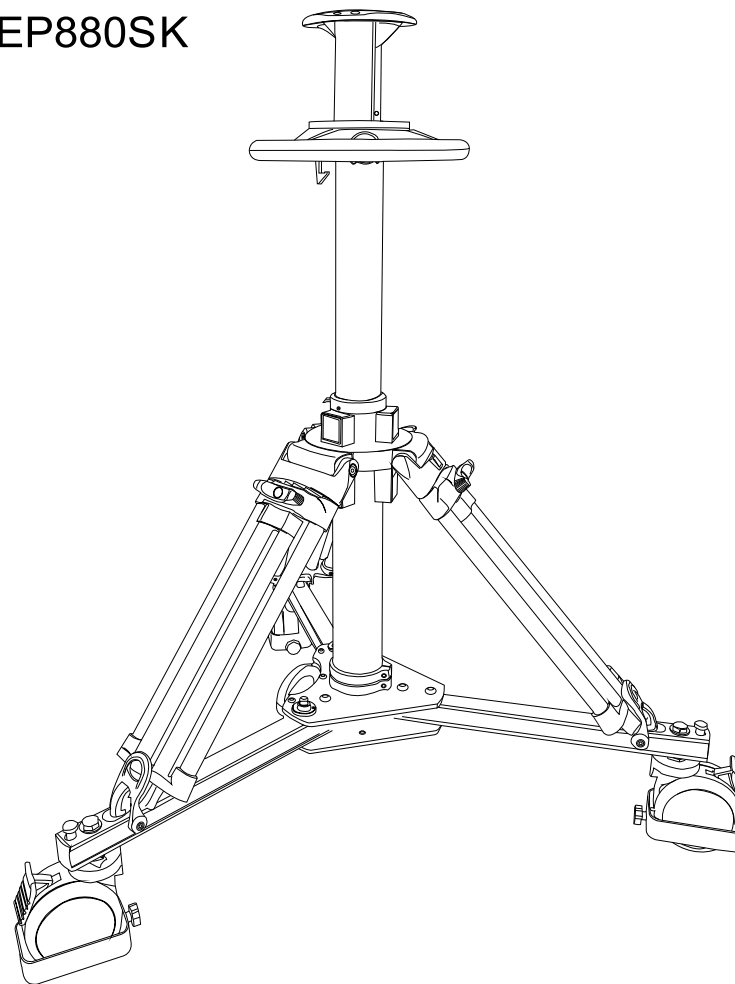

www.eimagevideo.com

Contents

Safety Notes

Specifications	1-2
A Part Diagram	3-4
B Setting up of the Pedestal	5
C Mounting the Head	6
D Air Pump Operation	7
E Air Release Valve	8
F Safety Lock Operation	9
G Column height adjustment	10
H Setting Up the Extension Column	11
I Cleaning and maintenance	11
Customer Information	12

Warning

Please read this manual completely before using the EP880XF / EP880XFK pedestal. Improper use could damage the equipment and/or lead to personal injury. This manual contains important information for proper equipment use and precautions to avoid personal injury.

Familiarize yourself with this manual and keep it handy for easy reference while pedestal is in use.

For your safety, follow all of the precautions and instructions listed below.

Safety Notes

- ▲ Failure to follow these precautions can result in personal injury.
- ▲ Keep your upper body away from the upper column while pumping air.
- ▲ If the air pressure exceeds necessary levels for the camera weight the column may quickly rise and cause injury or equipment damage.
- ▲ Engage the safety lock when removing your camera. Center column may rise quickly when the camera is removed.
- ▲ Do not exceed the load capacity of the pedestal or video head. Overloading the pedestal could result in spontaneous collapse or failure of equipment locks.
- ▲ Do not dismantle or remove any parts of the pedestal that are not designed to be removed. This may result in the warranty being voided, equipment damage, or personal injury.
- ▲ Check all safety equipment locks for tightness and effectiveness. If locks are not effectively tightened, equipment may slip or fall off, causing personal harm or damage to equipment.
- ▲ Engage all safety locks when storing or transporting the pedestal.
- ▲ Check the air pressure before using the pedestal. Air pressure can change while in transport, while being stored, or when there is a change in temperature. The relief valve can handle some changes, but the operator should always check the air pressure gauge before use.
- ▲ It is recommended to remove air completely during transport or long periods of storage.

A EP880S

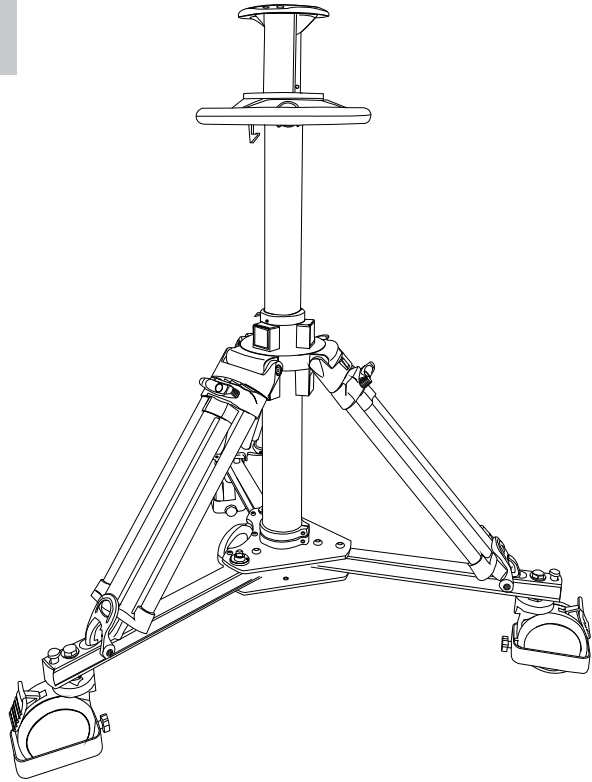

Model	EP880S
Max.Height range	165.0cm / 65.0in
Min.Height range	86.0cm / 33.9in
One-shot stroke	38.0cm / 15.0in
Payload	32.0kg / 70.4lbs
Net weight	24.2kg / 53.2lbs
Component	
Pedestal	EP880S
Dolly	EI-7007
Packing	Pedestal (Aluminum Case) Dolly (SC-5 Carrying Bag)

A EP880SK

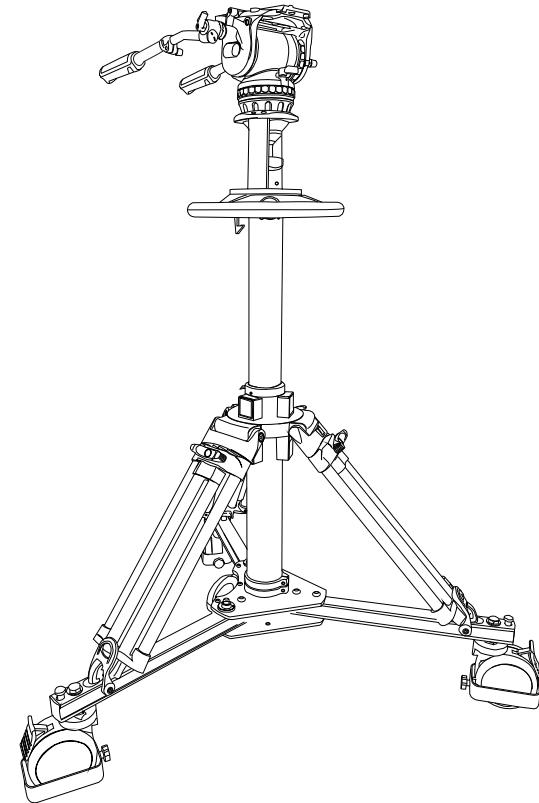

Model	EP880SK
Max.Height range	182.5cm / 71.9in
Min.Height range	103.5cm / 40.7in
One-shot stroke	38.0cm / 15.0in
Payload range	28.0kg / 61.5lbs
Net weight	28.8kg / 63.4lbs
Component	
Head	GH25
Pedestal	EP880S
Dolly	EI-7007
Packing	Head (Box Packing) Pedestal (Aluminum Case) Dolly (SC-5 Carrying Bag)

A EP880S

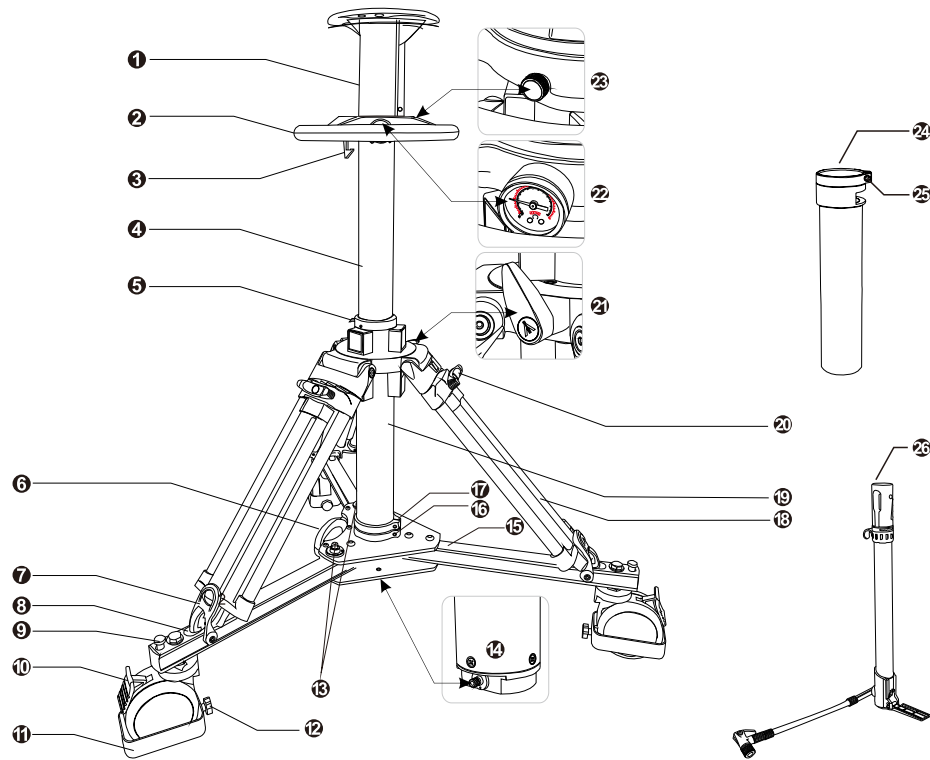

- | | |
|------------------------------|------------------------------------|
| 1.Head bowl | 14. Air Inlet |
| 2.Grip Wheel | 15. Dolly Leg |
| 3.Safety Locker | 16. Lower Column Lock Knob |
| 4.Upper Column | 17. Column Stopper |
| 5.Column Safety Latch | 18. Pedestal Leg |
| 6.Dolly | 19. Lower Column |
| 7.Rubber Foot Hook | 20. Leg Lock Knob |
| 8.Rubber Foot Hook Groove | 21. Upper Column Lock Knob |
| 9.Dolly Wheel Angle Lock | 22. Air Pressure Gauge |
| 10.Dolly Wheel Lock | 23. Air Pressure Bleed Valve |
| 11. Cable Guard | 24. Extension Column |
| 12. Cable Guard Height Lock | 25. Extension Column Locking Screw |
| 13. Dolly Leg Locking Button | 26. Air Pump |

A EP880SK

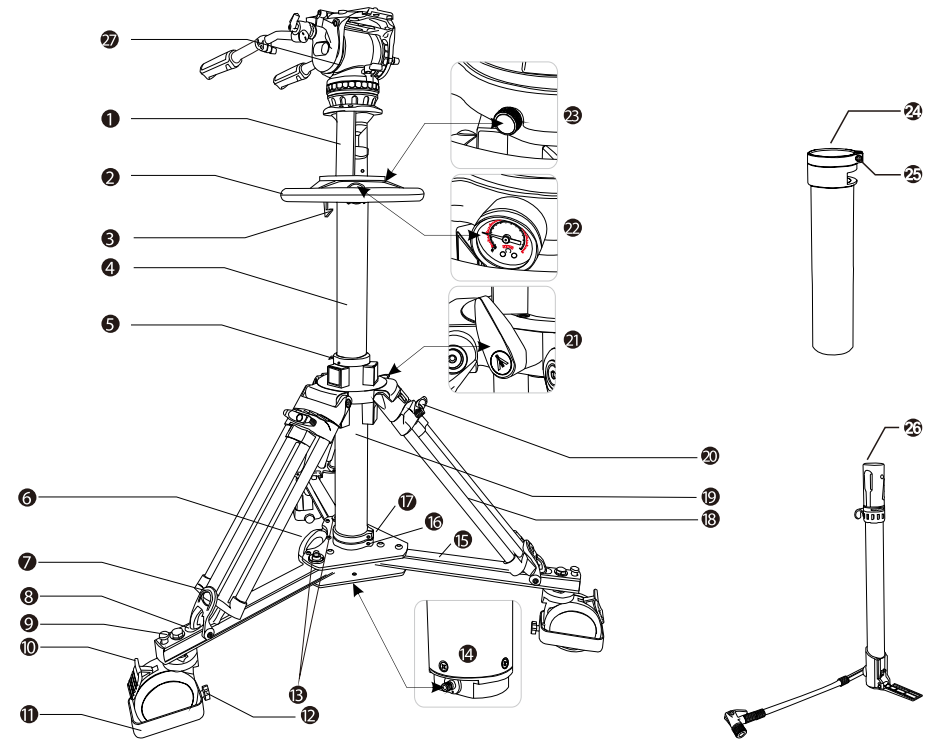

- | | |
|------------------------------|------------------------------------|
| 1.Head bowl | 15. Dolly Leg |
| 2.Grip Wheel | 16. Lower Column Lock Knob |
| 3.Safety Locker | 17. Column Stopper |
| 4.Upper Column | 18. Pedestal Leg |
| 5.Column Safety Latch | 19. Lower Column |
| 6.Dolly | 20. Leg Lock Knob |
| 7.Rubber Foot Hook | 21. Upper Column Lock Knob |
| 8.Rubber Foot Hook Groove | 22. Air Pressure Gauge |
| 9.Dolly Wheel Angle Lock | 23. Air Pressure Bleed Valve |
| 10.Dolly Wheel Lock | 24. Extension Column |
| 11. Cable Guard | 25. Extension Column Locking Screw |
| 12. Cable Guard Height Lock | 26. Air Pump |
| 13. Dolly Leg Locking Button | 27. GH25 Fluid Head |

B

B-1

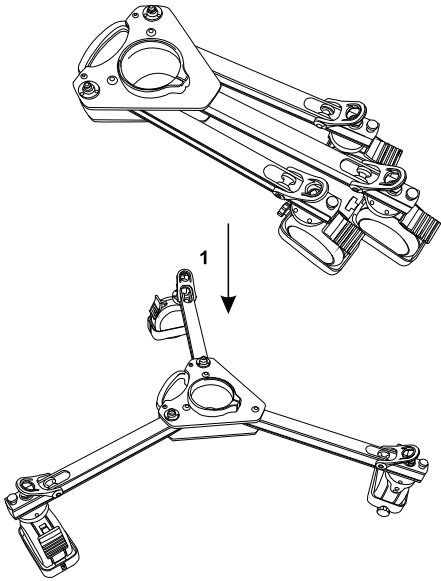

B-2

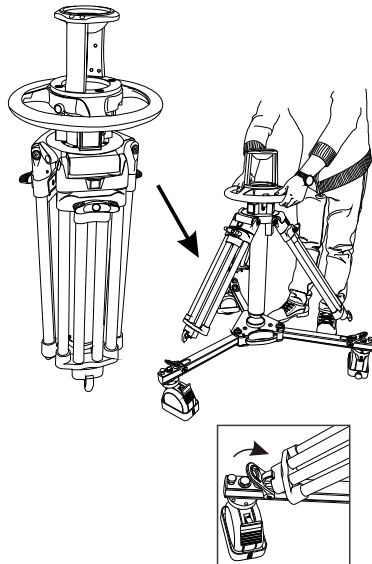

B: Setting up of the Pedestal

B-1: Setting up of the dolly

1. Remove the dolly from the box and spread the outer legs until the dolly leg locking buttons click into place.

B-2: Setting Pedestal on the dolly

1. Take the pedestal out of the box.
2. Spread the pedestal legs and insert the lower column into the center hole of the dolly until it stops at the column stopper.
3. Place the spiked feet over the rubber foot hook groove and secure the rubber hooks over the feet.
4. Engage the lower column lock.

C

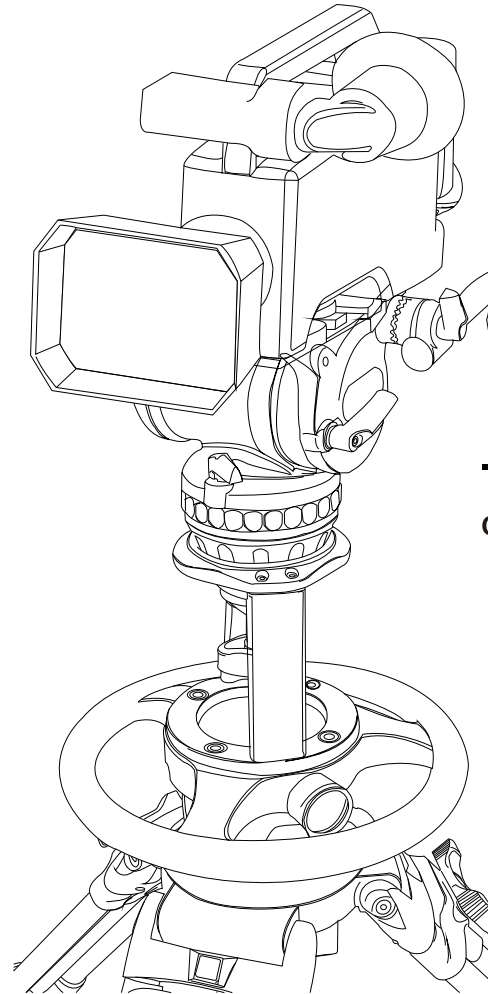

C: Mounting the Head

1. Place the GH25 Head into the 100mm bowl.
2. Secure the head with the locking knob and level the head using the built-in bubble level.
3. Attach the quick release plate to your camera and slide the plate onto the GH25 Head.

D

D-1

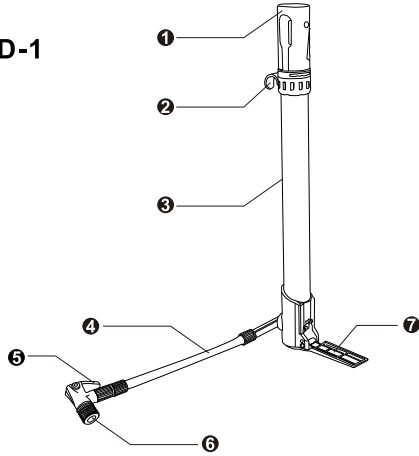

D-2

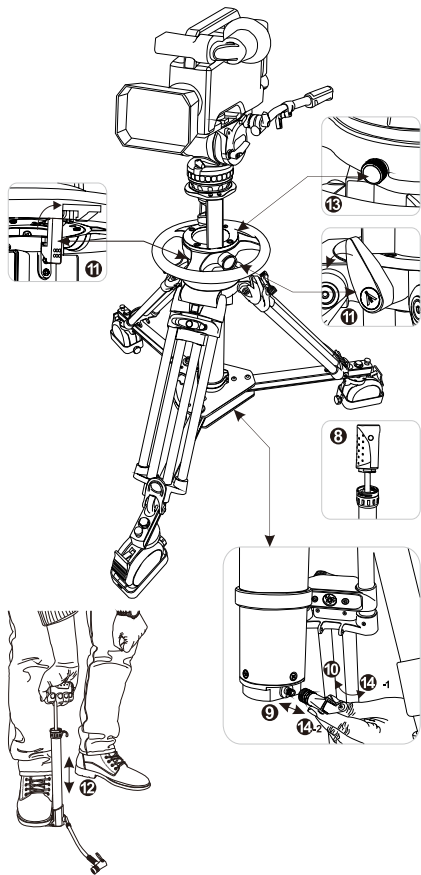

D: Air Pump operation

D-1: Air Pump Parts

1. Handle
2. Hose Hanger
3. Cylinder
4. Hose
5. Nozzle lock
6. Nozzle
7. Pump Feet

D-2: Air pump operation

1. Fully insert pump nozzle into air inlet.
2. Engage the nozzle lock lever and ensure the nozzle is secure.
3. Close the pedestal bleed valve and release the column lock and safety catch.
4. With the camera mounted on the pedestal, place the pump on stable ground and pump air into the column.
5. Continue adding air until the pedestal is at the required level. Use the bleed valve to release air if too much is added.
6. Unlock the pump nozzle and remove it from the air inlet.

E

E: Air Release Valve

It may become necessary to release air from the center column in certain circumstances like over-filling, storing, transport, and temperature changes. To release air:

1. Loosen the air release valve and air will begin to exit the column. The looser the valve, the faster the air leaves.
2. When enough air is out, tighten the valve until it is completely shut.

Attention :

- Air may leak from the valve if it is not completely tightened.
- DO NOT attempt to add air to the column through the air release valve.
- Make sure the column is lowered and locked before releasing air. Column may fall and cause damage or personal injury if it is not secured.

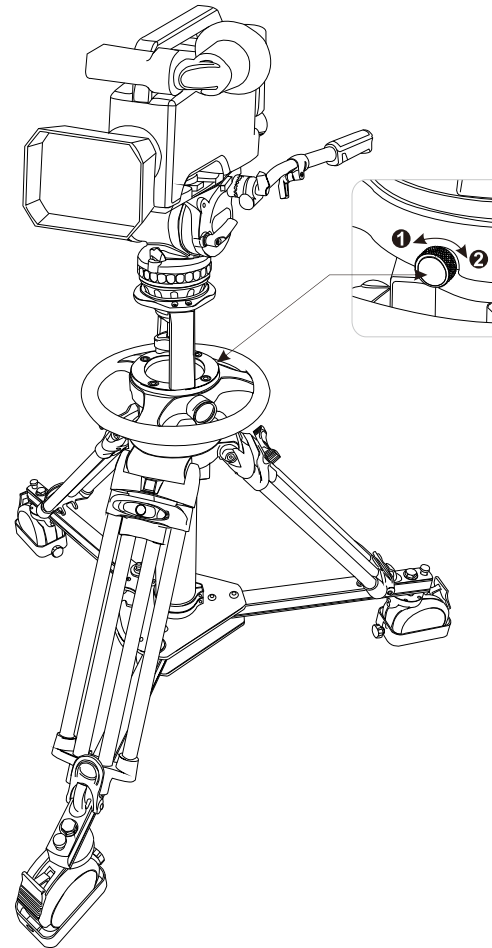

F

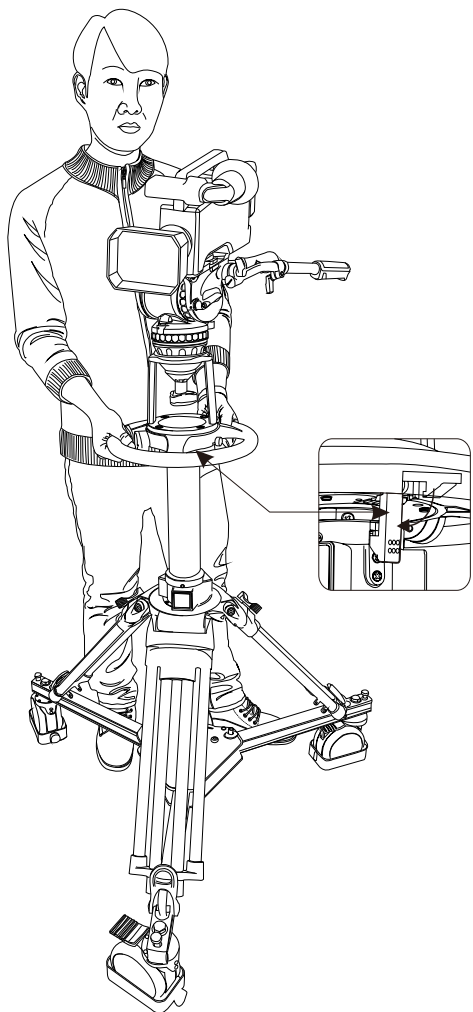

F: Safety lock operation

F-1: Engaging the Safety Lock

1. Hold the grip wheel and use your body weight to push the center column down as far as it will go.
2. Visually check the safety latch to make sure it has properly locked, and slowly reduce weight on the center column until locking is confirmed.

F-2: Release the safety locker

1. Hold the grip wheel and use your body weight to push down on the center column.
2. Release the safety latch and slowly allow the column to rise.

Attention :

- If air is still stored in the center column, the upper column may rise quickly and cause damage or personal injury. Make sure to keep weight on the column and allow it to rise slowly.
- DO NOT release the grip wheel until you are sure the column has risen as far as it can with the amount of air present in the column.

G

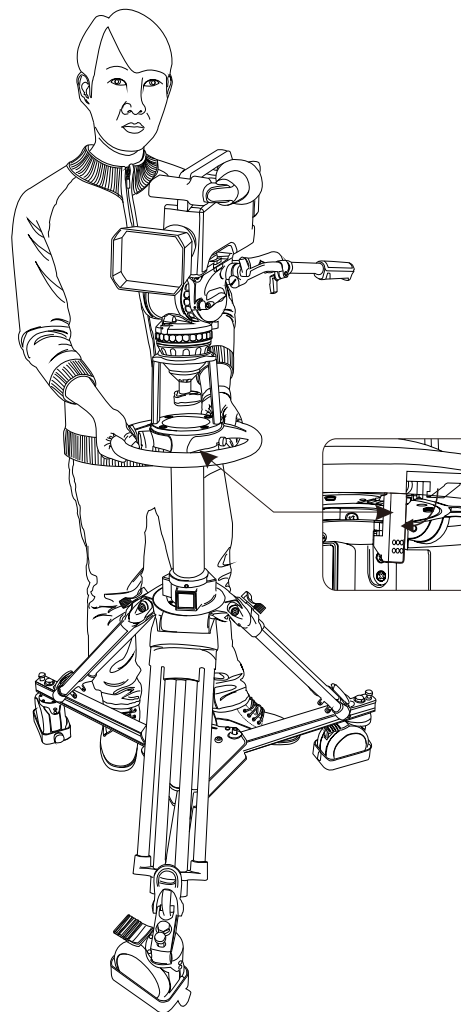

G: Column height adjustment

1. Unlock the upper column lock knob and release the column safety lock.
2. Adjust the upper column to the required height. Add air if it is too low, and release air if it is too high.
3. Lock the column lock knob.

Attention :

It is best practice to adjust column height while the camera is mounted on the pedestal.

H

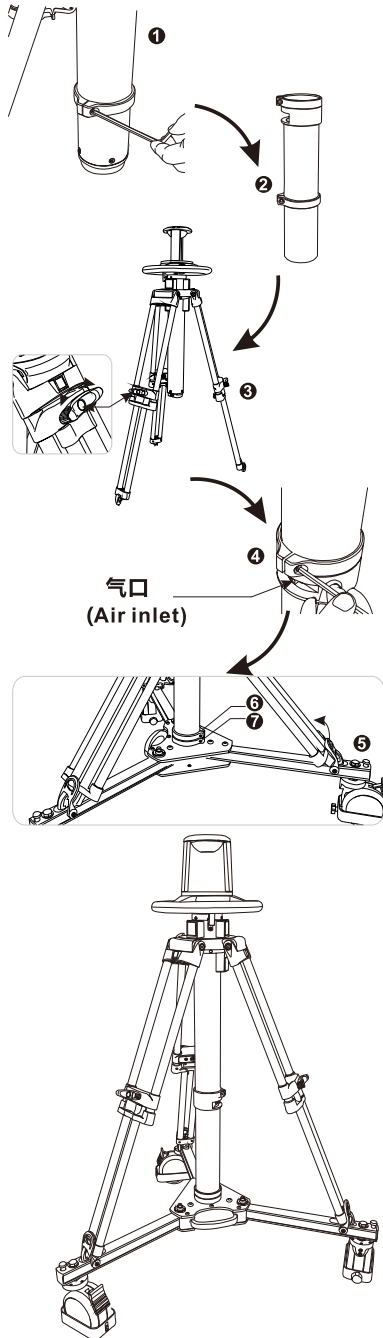

H: Setting Up the Extension Column

An extension column is included with the pedestal to securely add extra height to the pedestal.

1. Loosen the screw on the column stopper and slide the column stopper off of the lower column.
2. Install the column stopper on the bottom of the extension column.
3. Place the extension column into the central hole of the dolly until it stops at the column stopper.
4. Unlock the pedestal legs, and extend them fully, then locks the legs and attach the pedestal to the dolly, inserting the central column into the extension column and securing the rubber foot hooks onto the pedestal feet.
5. Secure the lower column lock on the extension column.

Attention:

Make sure the air inlet is exposed when inserting the central column into the extension column.

I

I: Cleaning and maintenance

We encourage regular cleaning of the product.

It should be wiped regularly with a clean and dry cloth to remove the dirt and dust during normal use.

Customer Information

Customer Name	Contact No.
Address	

Sales Manager

Sales Date	Dealer
Dealer Contact No.	

#1 Maintenance Record

Service Date	Signature of Repairman
Cause of Problem	
Service Result: <input type="checkbox"/> Solved <input type="checkbox"/> Unsolved <input type="checkbox"/> Refunded/ Replaced	