

Professional 15" High-Bright Beam Splitter Teleprompter

**OVERVIEW**

Ikan's professional teleprompter series is designed for a quick and easy setup to work efficiently in studio or broadcast applications. The teleprompter includes a 65/35 reflective glass that makes the reflection easier to see for the presenter. The lightweight aluminum teleprompter has multiple 1/4-20" and 3/8-16" threads for mounting to a tripod or pedestal. The monitor includes HDMI, Composite, and VGA video inputs. Its high bright screen ensures clear visibility in any lighting condition. An intuitive image flip button allows for easy adjustment of the display orientation. The monitor also features a wide viewing angle.

What's Included

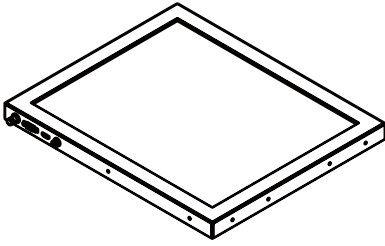

Monitor

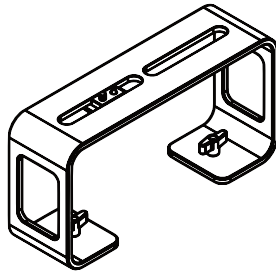

Tall Riser

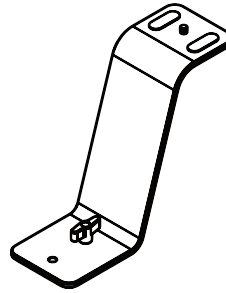

DSLR/Mirrorless Riser

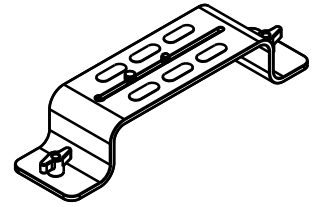

Short Riser

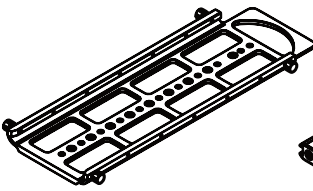

Sled

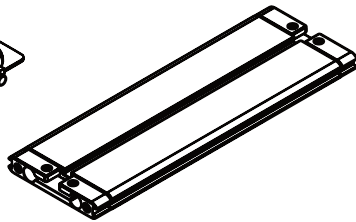

Base

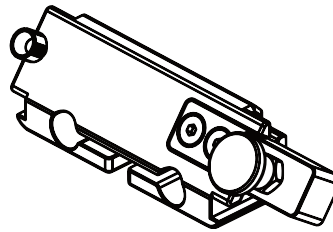

Glass Frame Holder Bracket
w/ Rod Clamps

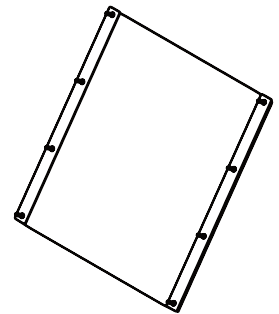

Glass

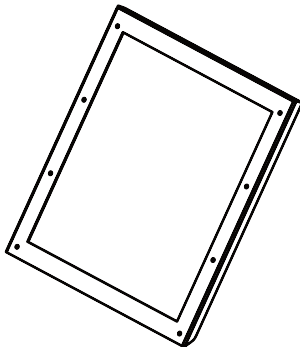

Hood Attachment Frame

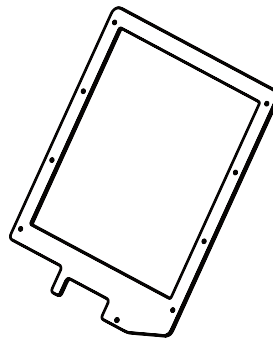

Glass Holder

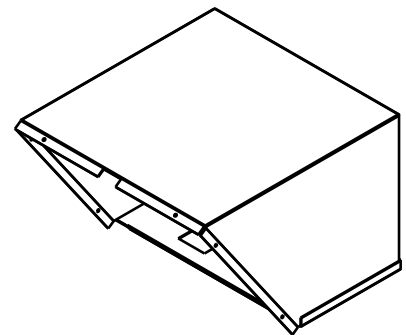

Hood

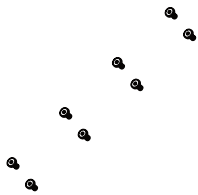

Glass Frame Screws

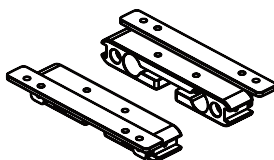

15mm Rod Clamps

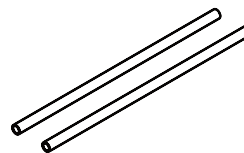

15mm Rods

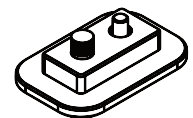

Large Riser
Bracket

Teleprompter Assembly Setup

Step 1

Place the Hood Attachment Frame over the Glass Holder. Then place the glass against the Glass Holder. Make sure the screws pass through the holes on the both the Hood Attachment Frame and the Glass Holder.

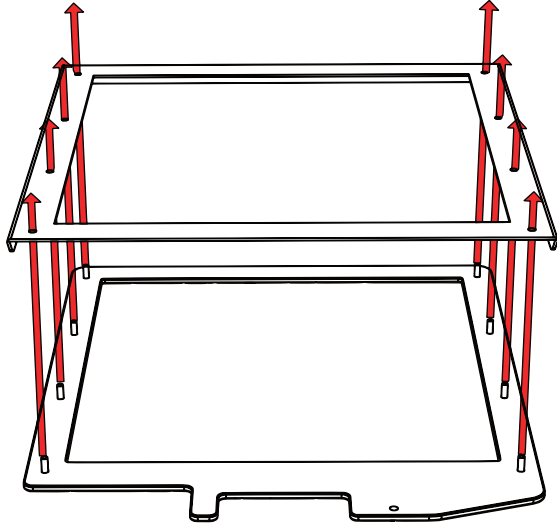

Step 2

Secure the Glass Holder by fastening the knurled nuts to the screws as pictured below.

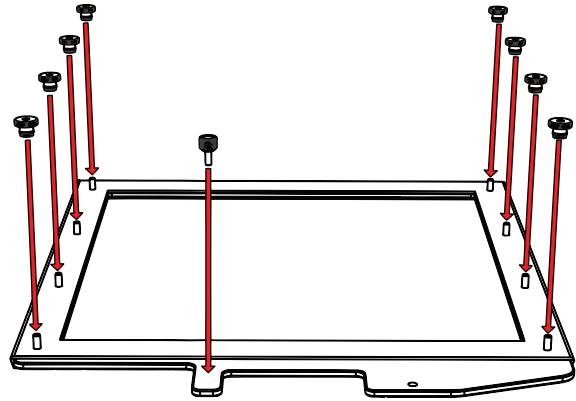

Step 3

Remove the monitor mounts from the teleprompter base using the included larger 4mm hex key to loosen from the 15mm rods.

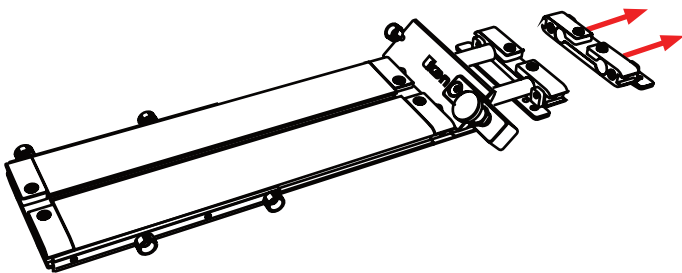

Step 4

Put the washers on before tightening the screws. The washers and 4 additional screws are inside a bag on the bottom foam.

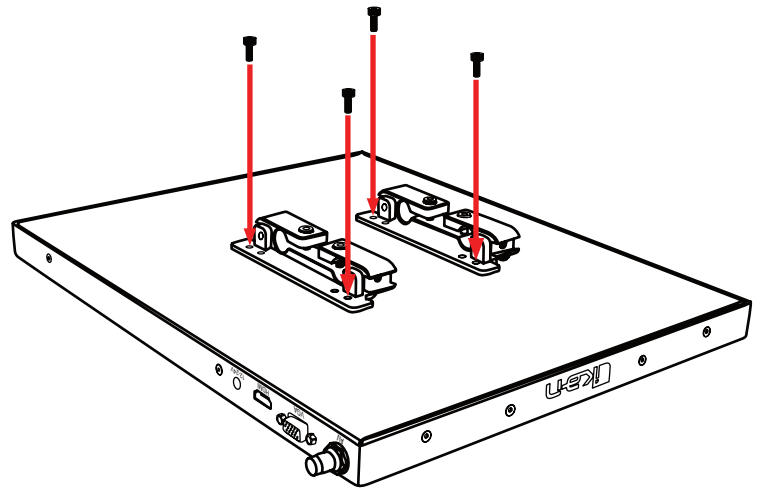

Step 5

After the monitor mounts are attached, adjust the 15mm rods to accommodate the monitor. Leave about 1 inch of room for the teleprompter bracket. Make sure the 15mm rods go through both set of monitor mounts. Please ensure that all screws are properly tightened after inserting the monitor.

SAFETY NOTE Make sure to leave at least 2 inches of the rods inside the teleprompter base.

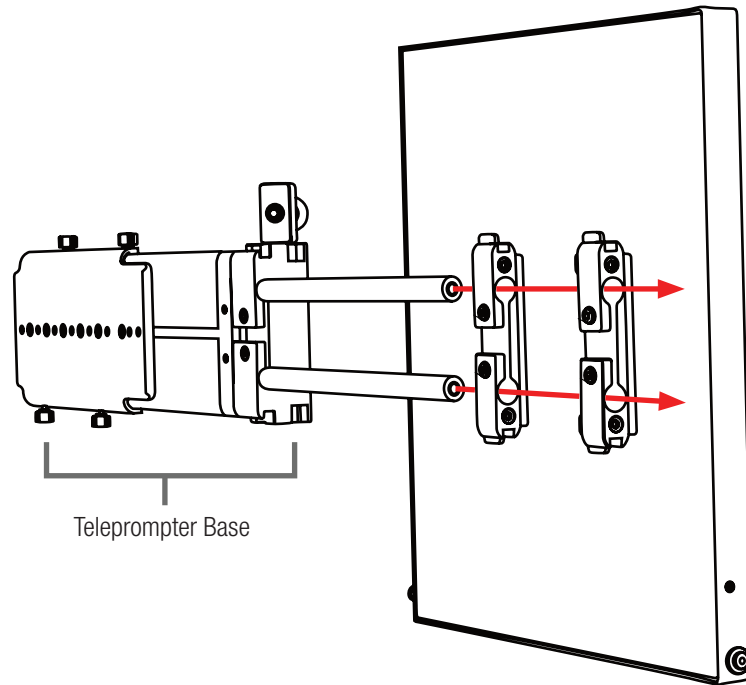

Step 6

While sliding the teleprompter bracket into the slot of the Glass Frame Holder Bracket, pull on the red knob to allow the bracket to fully slide in.

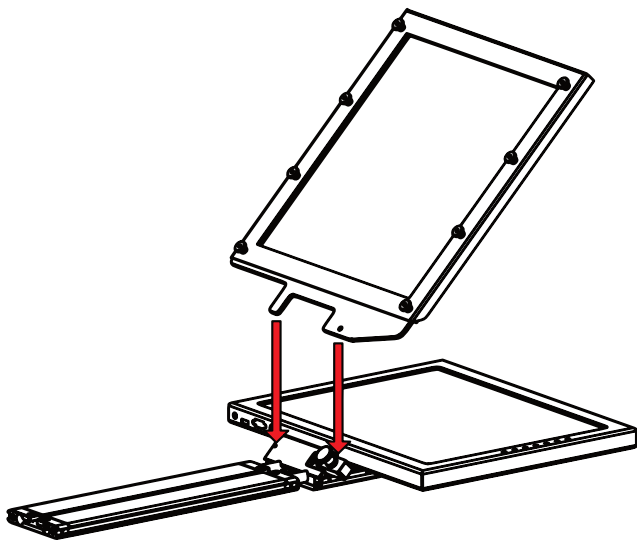

Step 7

Once the bracket is in place, tighten the side screw to lock in place. Double check and make sure all the screws are tightened with the included hex keys.

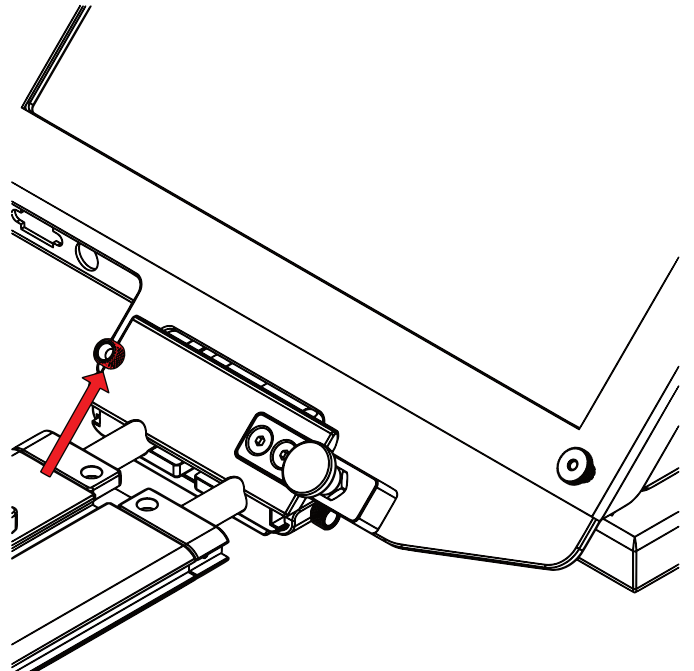

Step 8

Fold the flaps of the Hood alongside the edges of the Hood Attachment Frame. The Hood Attachment Frame includes six threaded clinch studs. Make sure to put the holes on the hood through the threaded clinch studs. The flaps of the Hood are magnetic so they will automatically attach and give extra support.

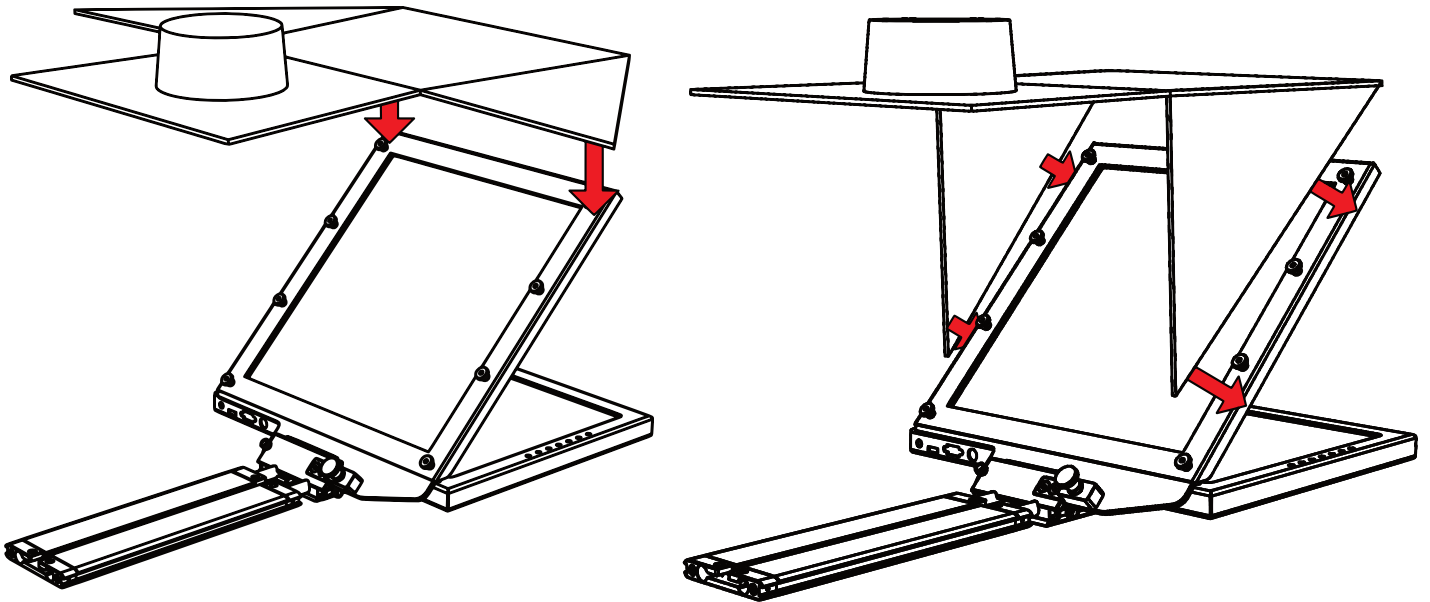

Step 9

To prevent light from leaking through the hood, seal both zippers down.

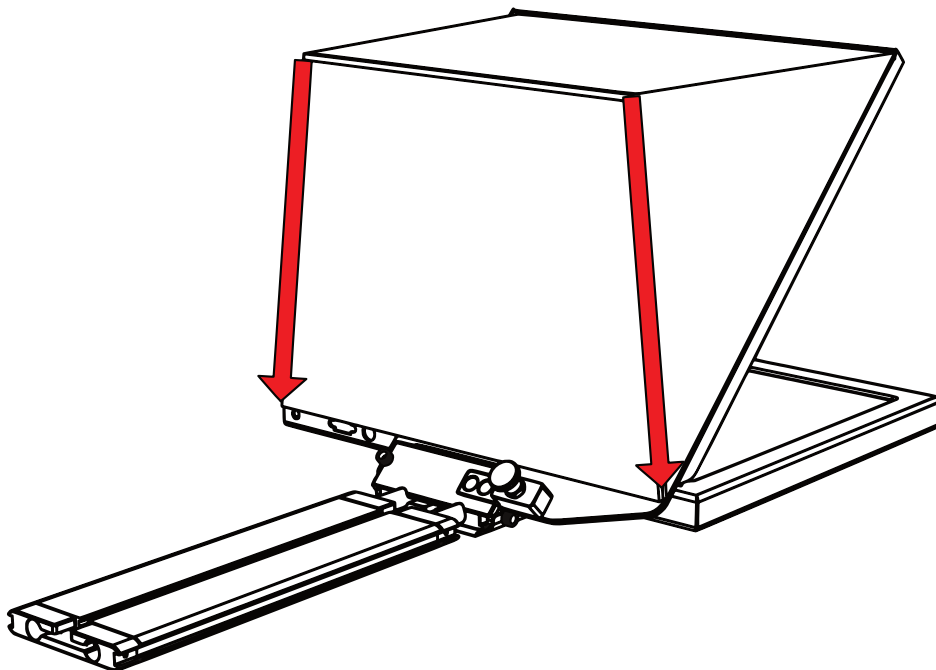

Step 10

Locate the threaded clinch studs on the Hood Attachment Frame and fasten the included nuts to the clinch studs.

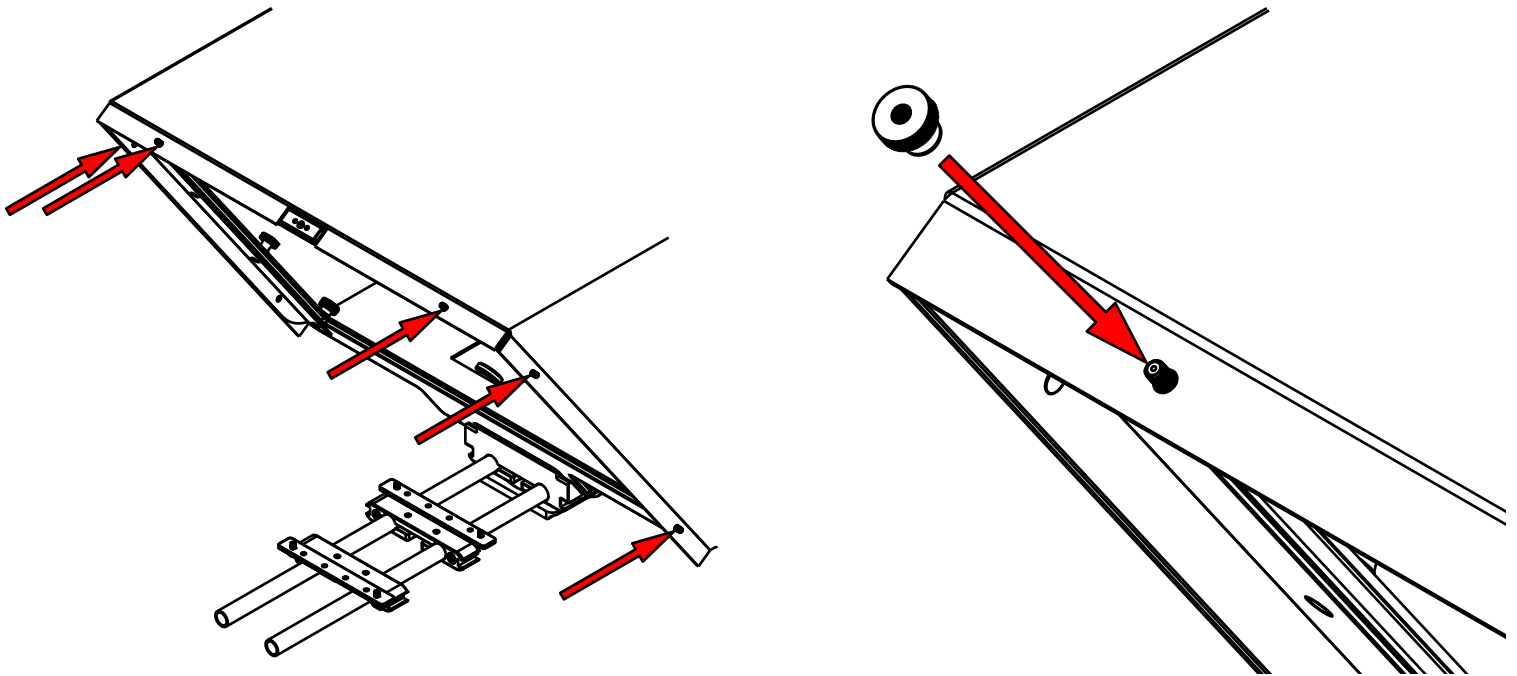

Step 11

Fasten all six of the nuts to the threads on the hood frame to secure the hood to the teleprompter.

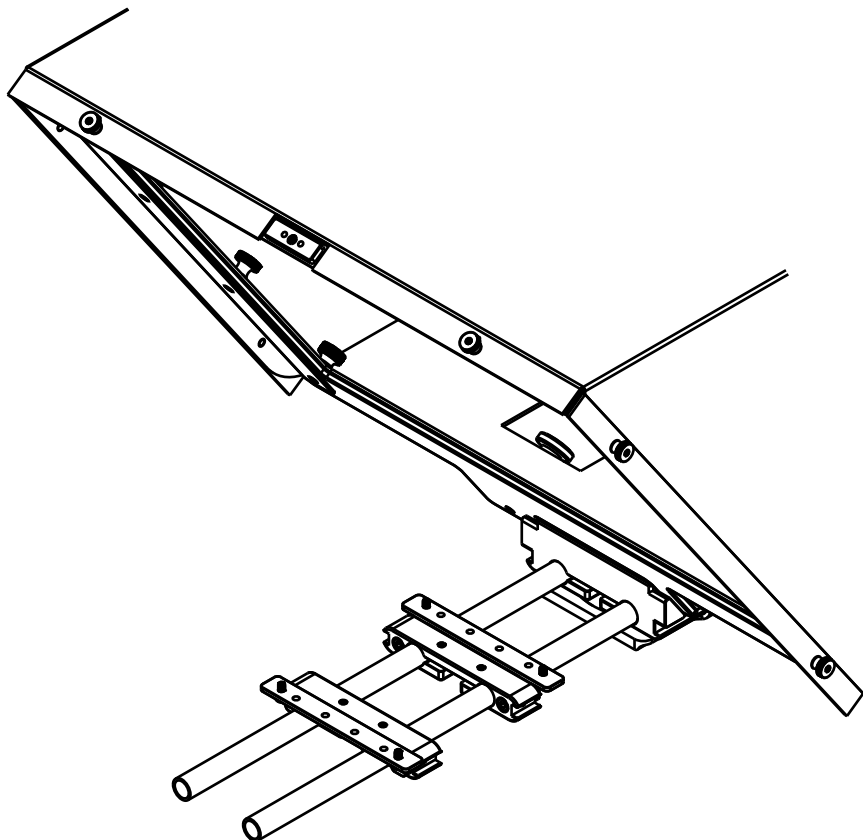

Step 12

If you need to use the Tall Riser Plate, you will need to use the Large Riser Bracket. Insert the Large Riser Bracket through the channel on the Tall Riser Plate. The Large Riser Bracket includes a location pin for use with cameras that feature a location pin hole. If your camera does not feature a location pin, you can remove the location pin by unscrewing it.

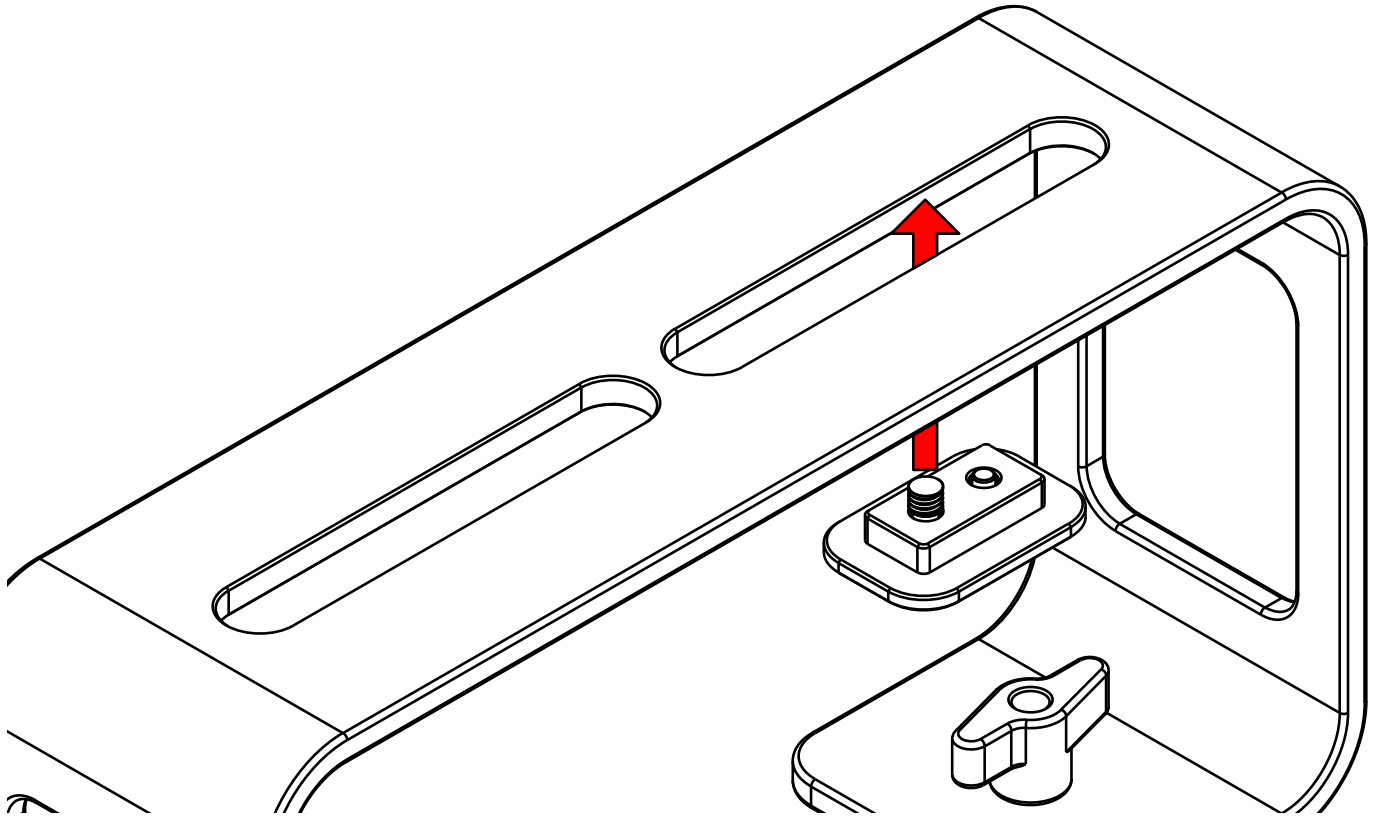

Step 13

Once the Large Riser Bracket is inserted into the channel. Hold it in place and move on to Step 14.

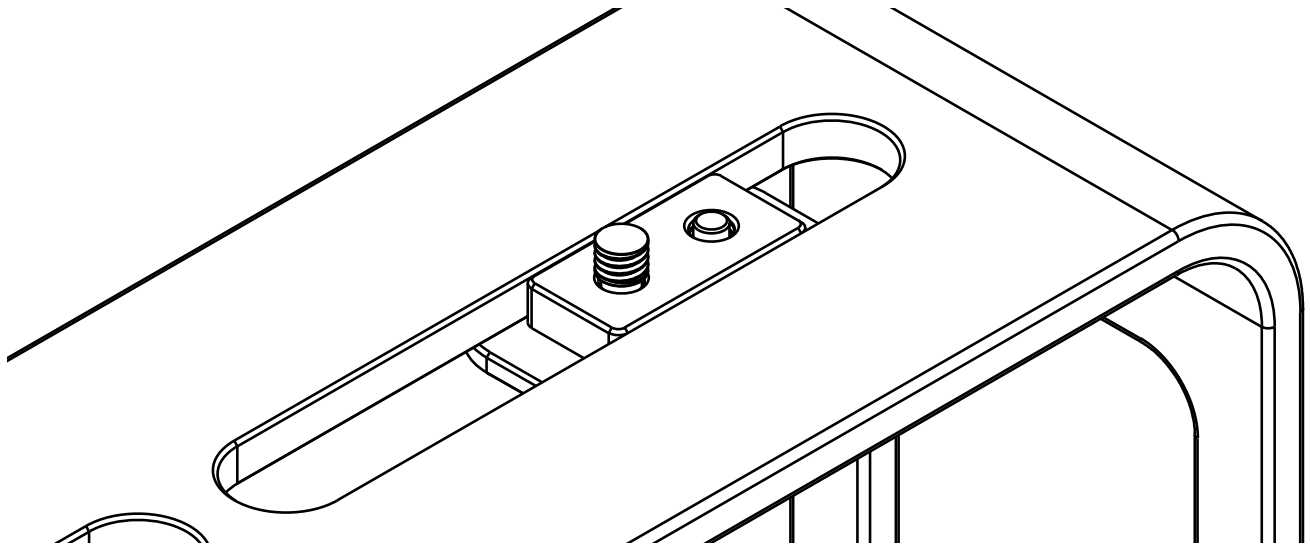

Step 14

Place the riser below your camera and fasten the 1/4-20 camera screw to the bottom of your camera to secure it to the riser plate.

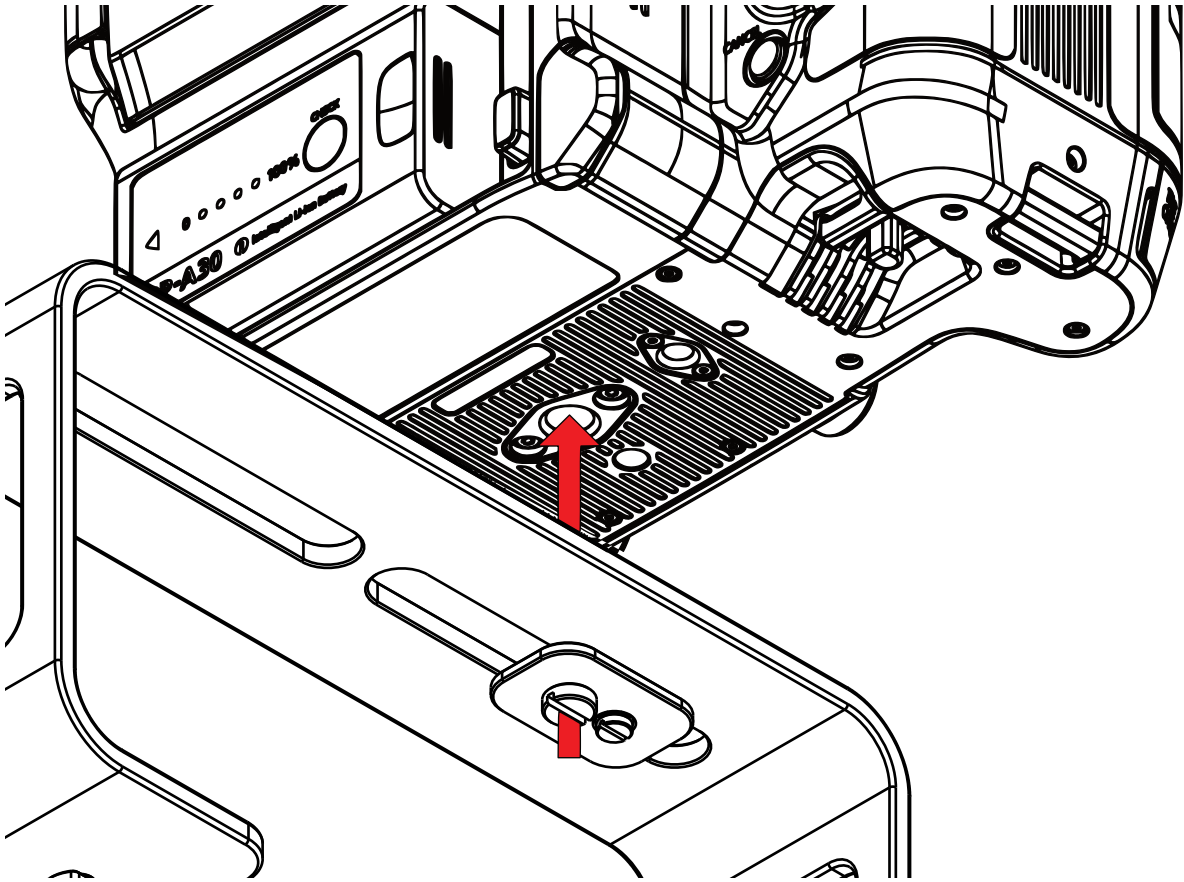

Step 15

Slide the threaded studs into the channel of the base. Make sure they are aligned to the spacing of the holes on the riser plate.

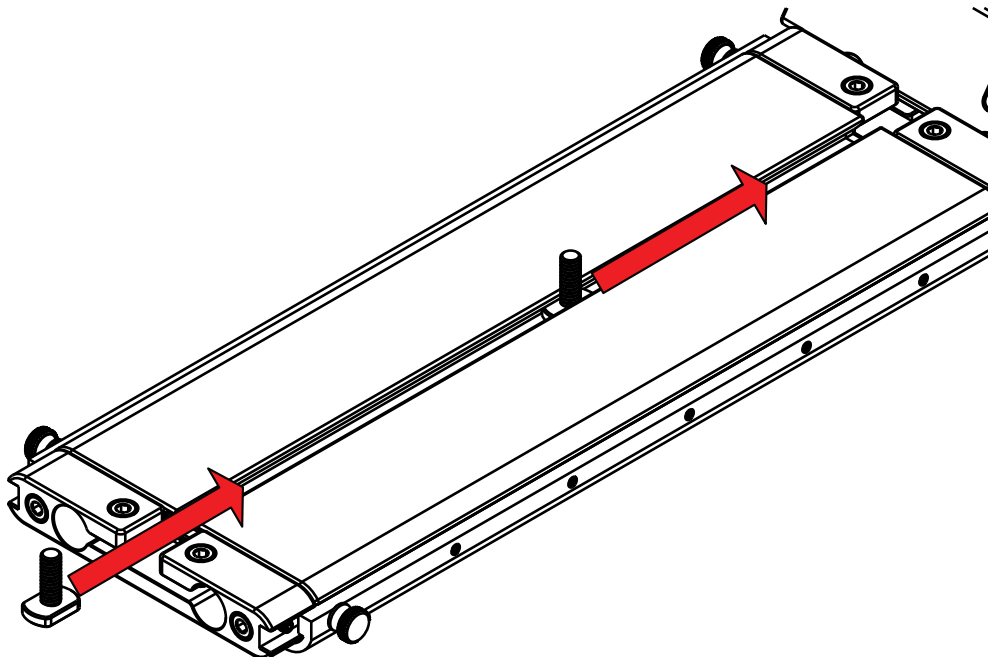

Step 16

Once the threaded studs are aligned to the holes of the riser plate, put the threaded studs through the holes of the riser plate.

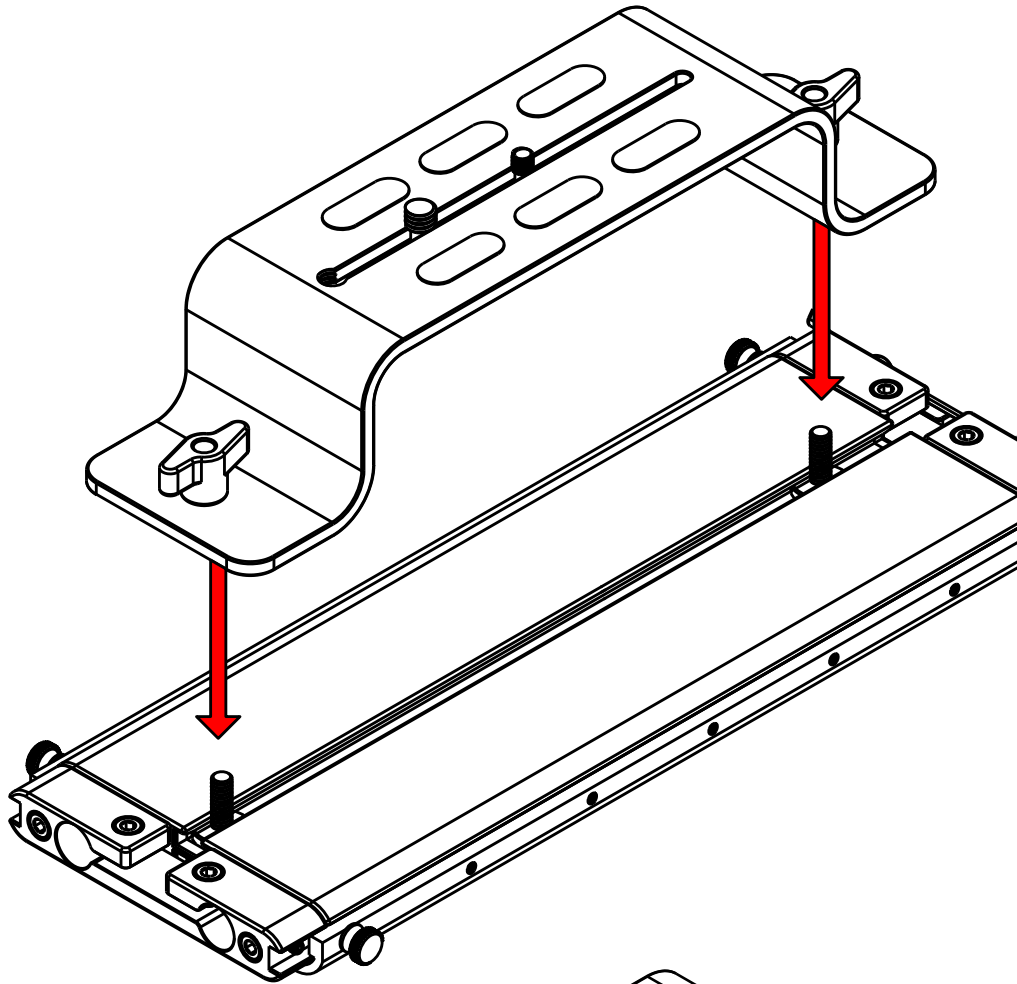

Step 17

Fasten the screws to the threaded studs to secure the riser plate to the base.

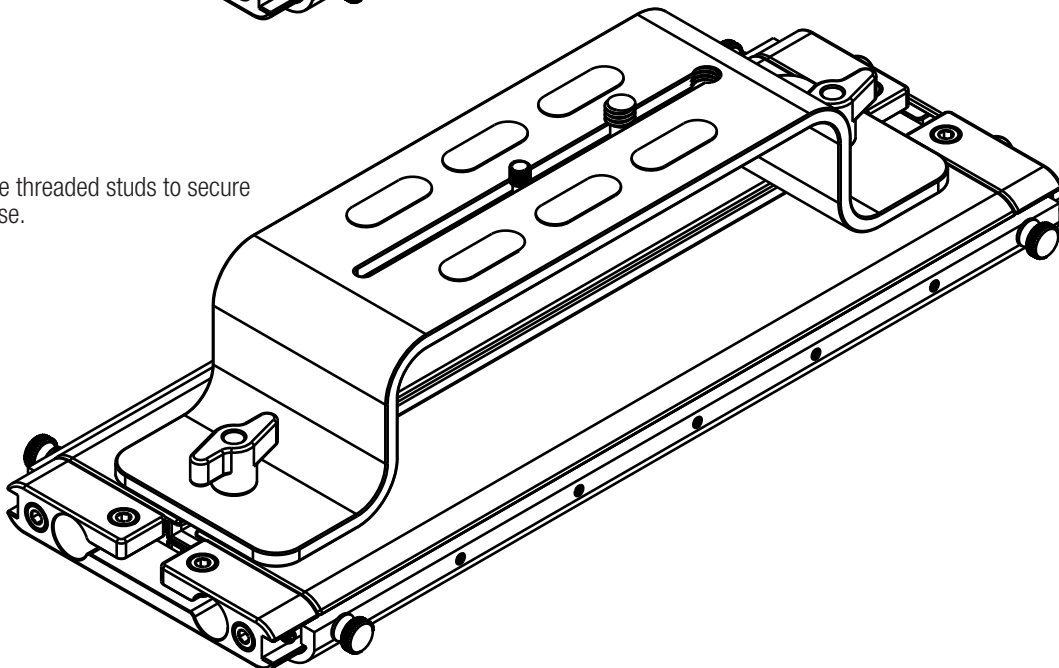

Step 18

Mount your own tripod plate to the sled by aligning the 1/4-20 and/or 3/8-16 screws and fastening them to the Sled. It is recommended that you connect your tripod plate to front of the Sled so that you can balance your teleprompter easier. Once your tripod plate is connected to the Sled, mount the tripod plate to your tripod head.

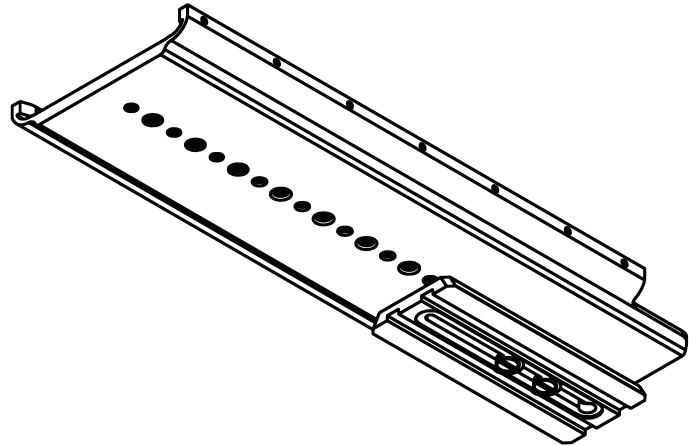
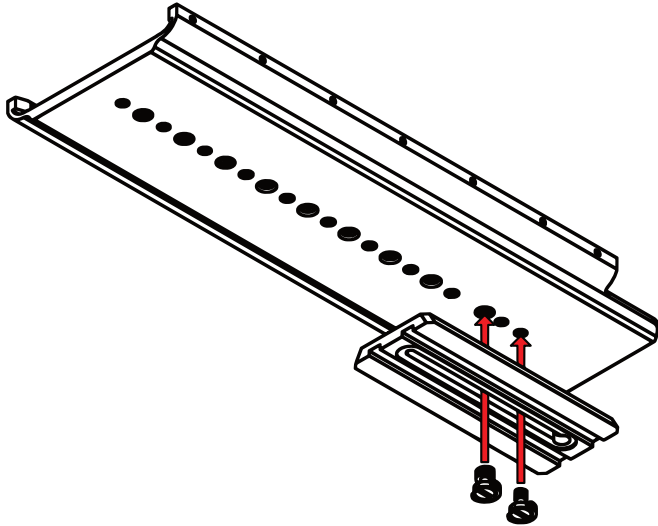

Step 19

Slide the entire teleprompter system into the Sled. Once the teleprompter system is inserted, you can balance it by sliding it along the Sled until the center of gravity is determined.

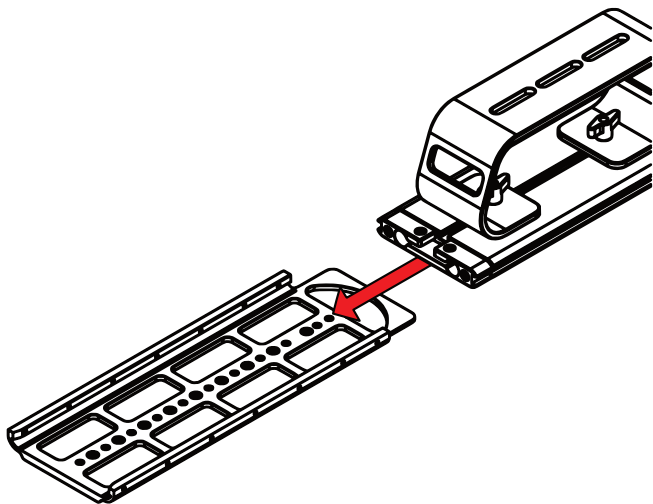

Step 20

Once the center of gravity has been determined, tighten the thumb screws to keep the base from sliding.

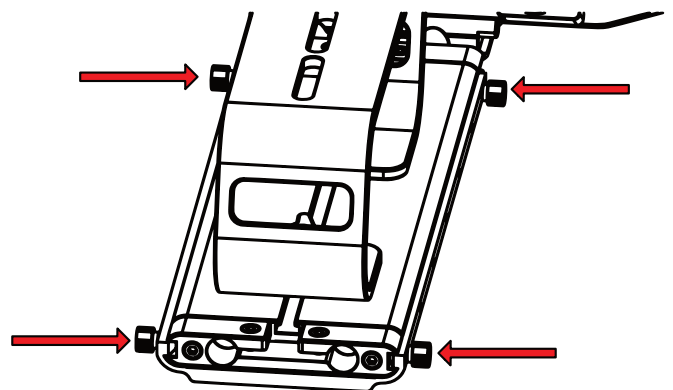

Step 21

To secure your teleprompter system, insert the included headless screws into the threads behind and in front of the Base.

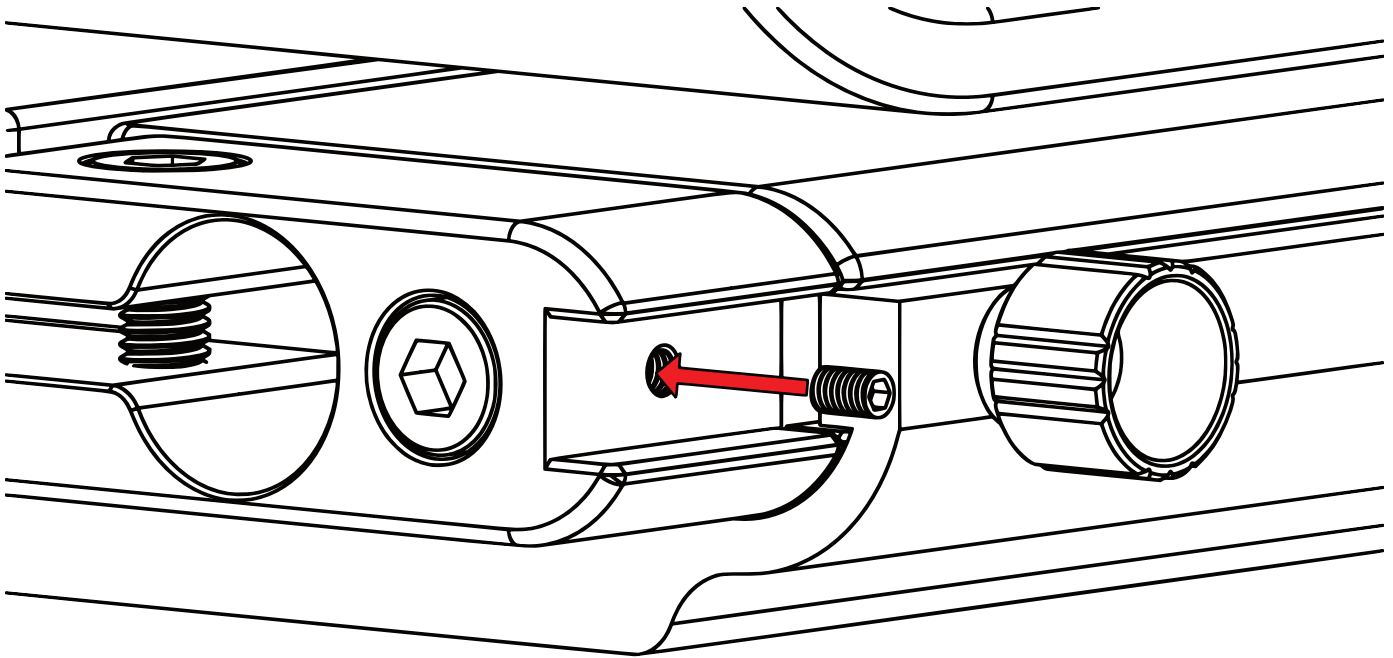

Step 22

The headless screws should be inserted to the threads as pictured below.

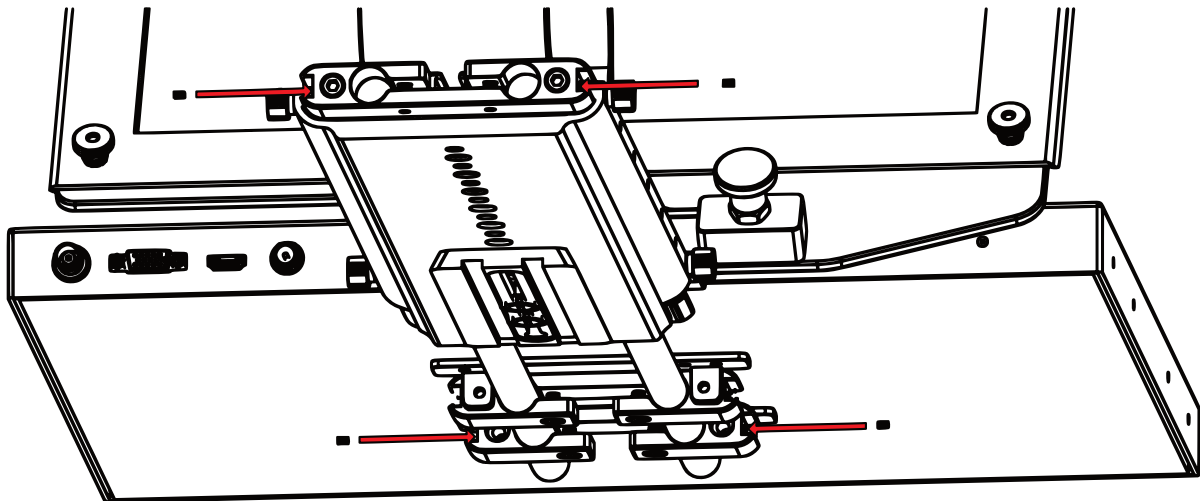

Monitor Ports

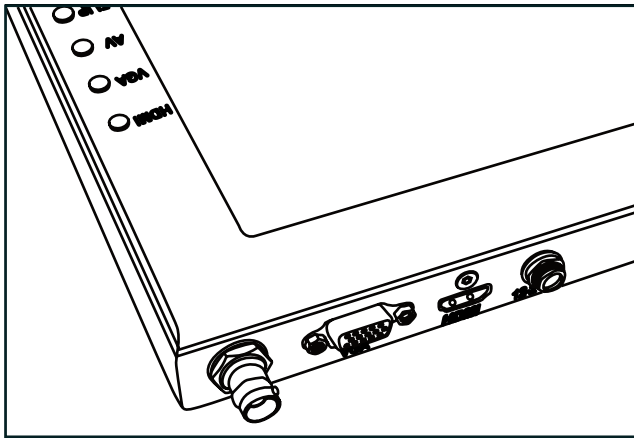

- BNC – AV Composite Input
- VGA – Video Graphics Array DE15 Connection
- HDMI – High-Definition Multimedia Interface Input Connection
- Power Port – 12-24v Input

Monitor Menu Settings

Video Config

- Contrast (White Level)
- Brightness (Black Level)
- Tint (Chroma Hue)
- Chroma (Chroma Saturation)
- Sharpness (Detail)
- RGB Setup – Manually configure RGB
- Return

System Config

- Menu Duration – Set duration of how long menu stays on screen
- Video Ratio – Set screen aspect ratio 16:9 or 4:3 (4:3 is native resolution, 16:9 will create black bars)
- Flip-H – Assign toggle button to flip image horizontally
- Flip-V – Assign toggle button to flip image vertically
- Reset – Factory reset
- Return

PC Setup (Only available for VGA)

- H-Position – Adjust horizontal position
- V-Position – Adjust vertical position
- Auto – Monitor automatically adjust position
- Return

Exit

How to set-up FLIP button feature:

1. Press MENU button
2. Navigate to SYSTEM CONFIG.
3. Navigate to FLIP-V or FLIP-H
4. Change FLIP-V and/or FLIP-H to "ON"
5. Exit MENU
6. The FLIP button should now be activated and can be pressed to mirror the image Horizontally or Vertically
7. When FLIP-H is ON, the image will flip Horizontally
8. When FLIP-V is ON, the image will flip Vertically
9. If both are ON, the FLIP button will toggle both Horizontal and Vertical flip

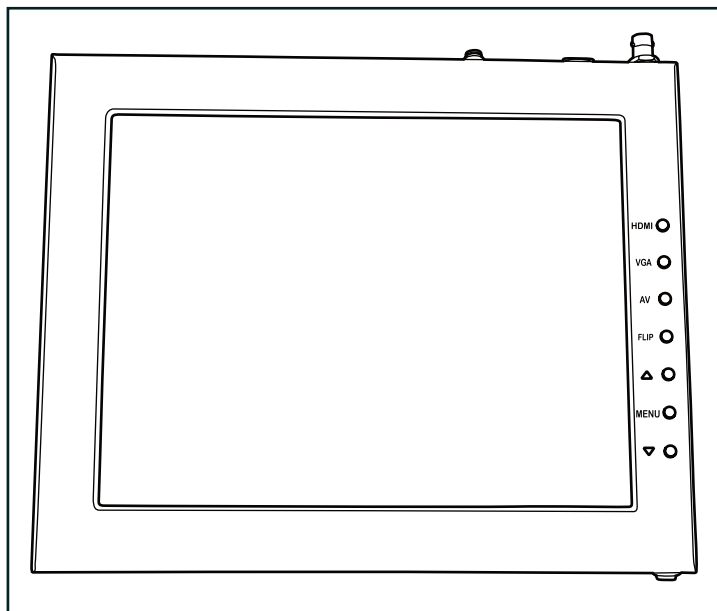

- HDMI – Switch HDMI input
- VGA – Switch to VGA input
- AV – Switch to composite BNC input
- Flip – Toggle image flip
(Can be set to horizontal, vertical, or both via menu)
- Up Arrow – Toggle up to adjust setting
- Menu – Access to monitor settings
- Down Arrow – Toggle down to adjust setting

Watch our VIDEO TUTORIAL on how to assemble PT4500-V3 Teleprompters:

<https://ikancorp.com/pt4900-v2-tutorial-videos/>



Specifications

PT4500-V3

15 in. Teleprompter

Riser Plate Height	Short: 2.06 in./52.5mm Tall: 5.31 in./135mm DSLR: 6.29 in./160mm
Length of Rods	15mm x 400mm
Build Material	Chassis: Anodized Aluminum Rods: Carbon Fiber
Reading Range	25 ft. / 7.62 m
Beamsplitter Ratio	65/35
Beamsplitter Shape	Rectangular
Beamsplitter Material	Glass
Tripod Mounts	11 x 1/4 in. -20 Female 9 x 3/8 in. -16 Female
Product Weight w/ Low Plate	29.6 lbs.
Product Weight w/ Medium Plate	30 lbs.
Product Weight w/ High Plate	30.13 lbs.
Product Weight w/ DSLR Plate	29.5 lbs.
Height of Teleprompter	16.1 in./ 411mm

15 in. Teleprompter Monitor

Aspect Ratio	4:3
Maximum Brightness	1000 cd/m2
Screen Size (Diagonal)	15 in.
Mount	VESA 100mm
Video Inputs	AV COMPOSITE, HDMI, VGA
Input Voltage	DC 12v
Power Consumption	28W
Product Weight	3.97 lbs.
Product Dimensions	12.13 in. x 14.25 in. x 1 in.
Native Resolution	1280 x 1024
Viewing Angle	160° (H) / 170° (V)
Build Material	Aluminum Chassis
Image Flip	Horizontal: Yes Vertical: Yes

Optional Accessories

PT4U-G	Replacement Glass for PT4500-V3
M15W	15" Talent Monitor Add On Kit for PT4500-V3
PT-PEDAL	Teleprompter Foot Control Pedal
PT-CONTROLLER	Teleprompter Rotary Controller
PT-CASE-4U	Rolling Hard Case for PT4500-V3 Teleprompter



Foam Case

To make your teleprompter more portable, we packed it in a reusable, high-quality foam. The shape and size of the foam was designed to fit into Ikan's PT-CASE-4U



****DO NOT THROW AWAY FOAM CASE****

Learn More

More dynamic information at official website: www.ikancorp.com

Support

Contact email: support@ikancorp.com

CONDITIONS OF WARRANTY SERVICE

- Free service for one year from the day of purchase if the problem is caused by manufacturing errors.
- The components and maintenance service fee will be charged if the warranty period is expired.

Free Service will not be Provided in the Following Situations:(*Even if the product is still within the warranty period.)

- Damage caused by abuse or misuse, dismantling, or changes to the product not made by the company.
- Damage caused by natural disaster, abnormal voltage, and environmental factors, etc.

©2024 Ikan International. All rights reserved.