



What's Included

- 1 x 18" Ring Light
- 1 x 18" Carry Bag
- 1 x Phone Mount
- 1 x Power Cord
- 1 x Remote Control

Warning

- Do not expose the light to rain or extreme moisture conditions.
- The ring light does not have charging capabilities. Use a dedicated charger to charge batteries.
- Do NOT use both AC adapter and battery at the same time.
- Do not attempt to open or modify the ring light.

Light Overview

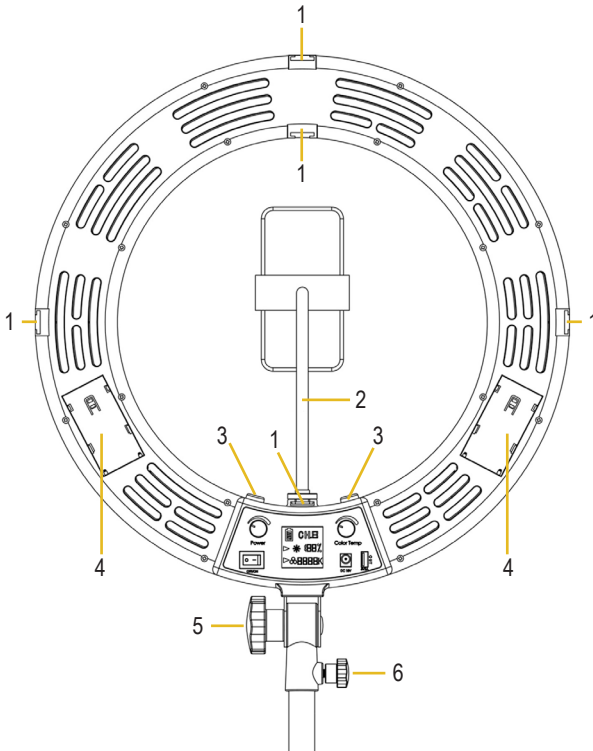

1. Shoe Mounts
2. Smartphone Holder
3. 1/4" - 20 Threads
4. Battery Slots
5. Light Angle Knob
6. Locking Knob
7. Brightness/Standby Knob
8. Color Temperature Knob
9. Power Switch
10. 18V DC Port
11. 5V 2A USB Power Output
12. Battery Level Indicator
13. Ring Light Mode
14. Brightness Display
15. Color Temperature Display

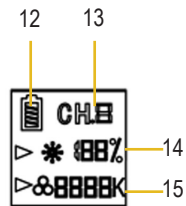
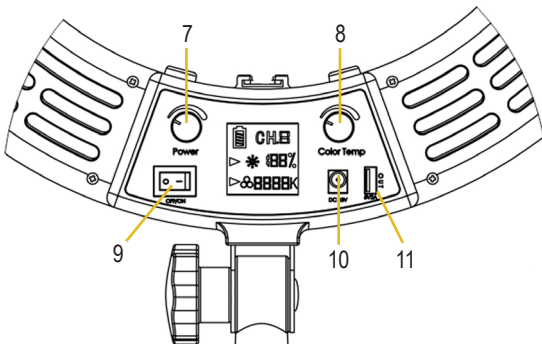

Basic Operation

The light can be powered with either the included power adapter or with L Series battery. For L series battery use either the F750 or F970.

Press the switch to the on side to power the light on. You can put the light into a standby mode by pressing the Brightness Knob. This will turn the LEDs off. While in standby mode the light can still be controlled with the included remote control.

Use the Brightness Knob to adjust the brightness from 0% to 100%. Brightness increases and decreases by values of 1%.

Use the Color Temperature Knob to adjust the color temperature from 2700K to 5600K. Color temperature increases and decreases by values of 100K.

Remote Control Operations

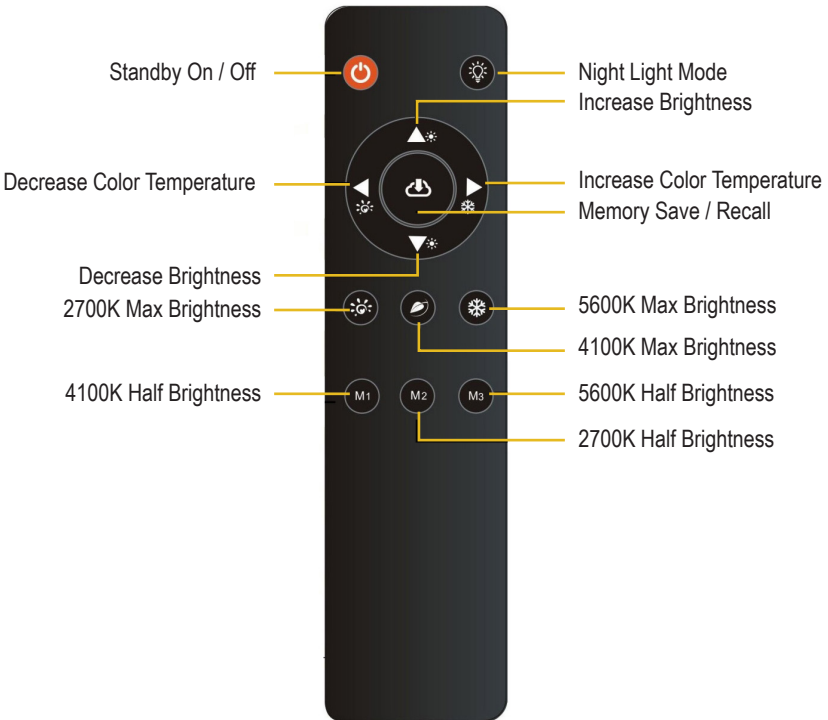

Ring Light Modes

Ch.0 – Standby Mode

Ch.1 – Manual Control Mode

Ch.2 – 5600K @ 50% Brightness

Ch.3 – 4100K @ 50% Brightness

Ch.4 – 2700K @ 50% Brightness

Ch.5 – 4100K @ 100% Brightness

Ch.6 – 5600K @ 100% Brightness

Ch.7 – 2700K @ 100% Brightness

Ch.8 – 4100K @ 4% Brightness

Specifications

Input Power	110V/240V 50Hz/60Hz
Output Power	90W
Brightness Range	0% - 100%
Color Temperature	2700K - 5600K
CRI	97
TLCI	98
Dimensions	Internal Diameter - 12.4 in. / 31.5 cm Outer Diameter - 18 in. / 45.5 cm Thickness - 1.4 in. / 3.5 cm



Learn More

More dynamic information at official website: www.ikancorp.com

Support

Contact email: support@ikancorp.com

CONDITIONS OF WARRANTY SERVICE

- Free service for one year from the day of purchase if the problem is caused by manufacturing errors.
- The components and maintenance service fee will be charged if the warranty period is expired.

Free Service will not be Provided in the Following Situations: (Even if the product is still within the warranty period.)

- Damage caused by abuse or misuse, dismantling, or changes to the product not made by the company.
- Damage caused by natural disaster, abnormal voltage, and environmental factors, etc.

©2020 Ikan International. All rights reserved.

