

# PT-ELITE-UL-RC

## QUICKSTART GUIDE

Elite Large Universal Tablet Teleprompter Kit w/ Elite Remote



ikan

[www.ikancorp.com](http://www.ikancorp.com)

[support@ikancorp.com](mailto:support@ikancorp.com)

|                   |
|-------------------|
|                   |
| <b>CHECKED BY</b> |

713.272.8822

© 2015 ikan Corporation. All rights Reserved

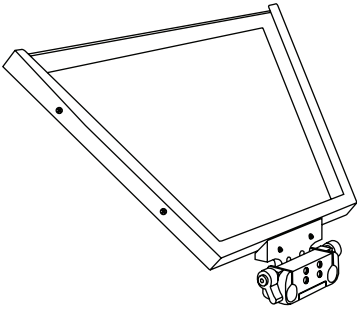

□□ Glass Frame

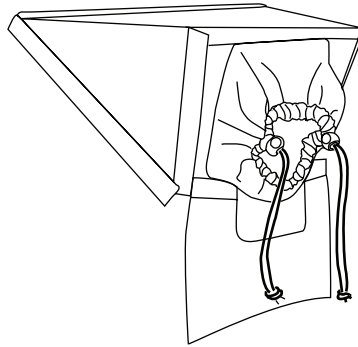

□□ Hood

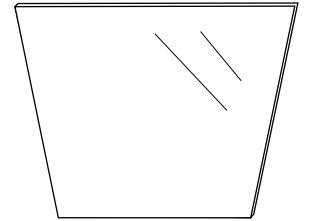

□□ 30/70 Prompter Glass

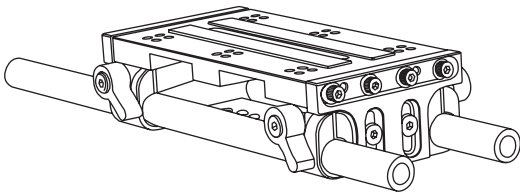

□□ EV2 Adjustable Camcorder Baseplate (Large)

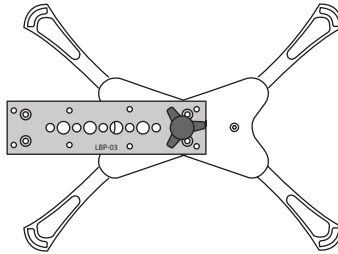

□□ iPad Teleprompter Mount

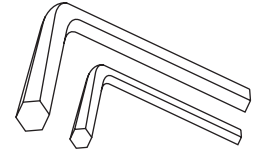

□□ 1 x Hex Key 3mm  
1 x Hex Key 2.5mm



□□ 4 x Bumper



□□ 1 x D-Ring



□□ 2 x 4mm X 12mm Socket Head Countersink Screw

# Getting Started

1. Fit Frame to iPad Mount. Secure with 2 x Socket Head Countersink Screw.

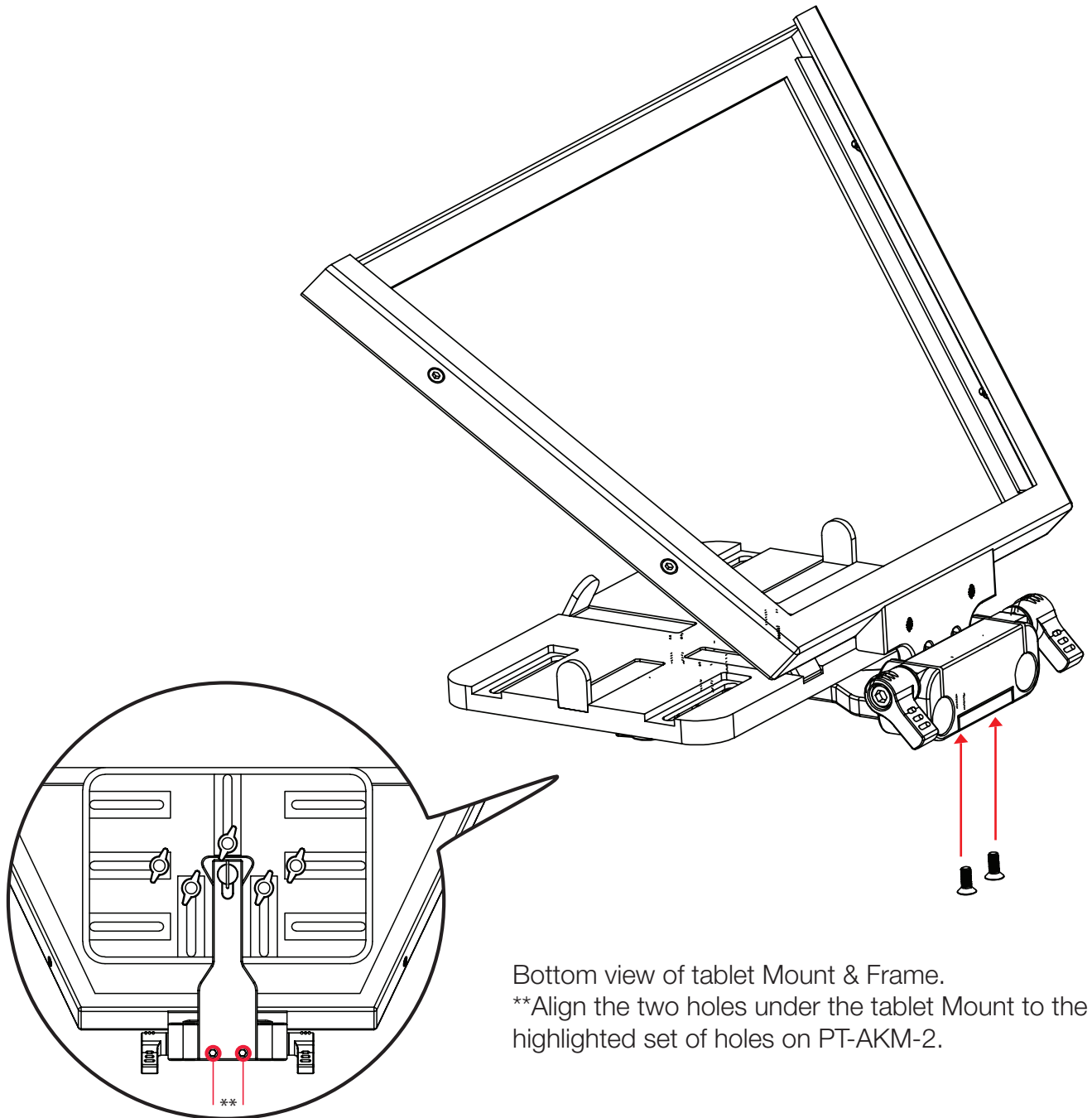

2. Remove 4 x Small frame screws and 2 x brackets.  
Insert prompter glass into frame. Secure prompter glass by replacing brackets and screws.

\*\* Glass with more reflectivity faces out.

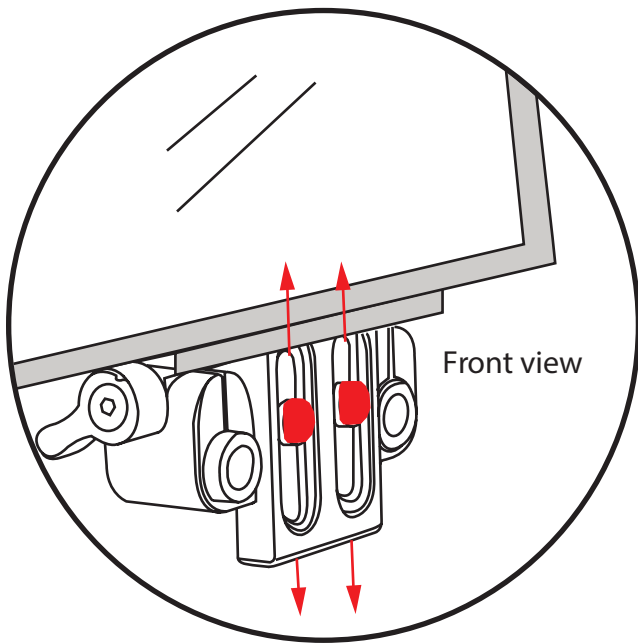
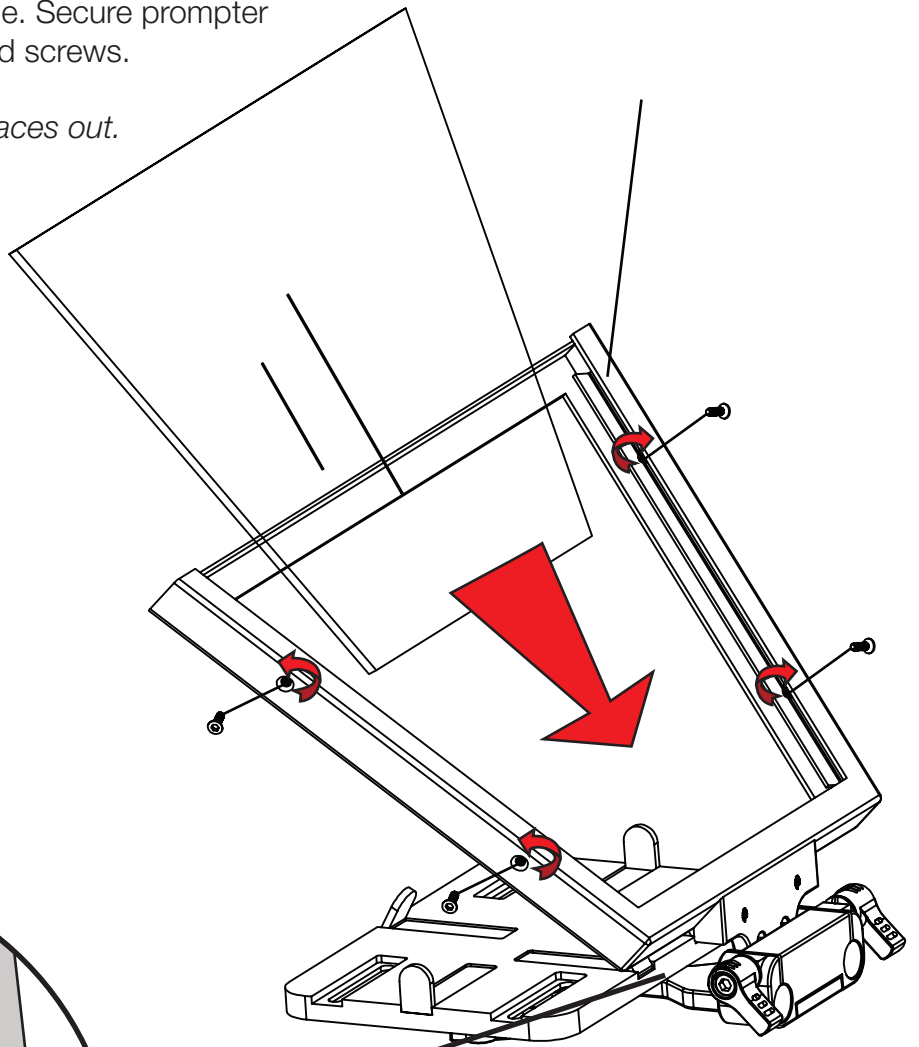

Vertical Adjustments to the frame can be made by loosening the Hex Screws located on the inside of the unit.

**Adjustment Points** (Adjust to fit your camera size)

Numerous Adjustment Points allow for precise positioning modifications. Loosen Thumb Screws to move forward/backwards along 12" Rods. Loosen Hex Screws to make vertical and horizontal adjustments.

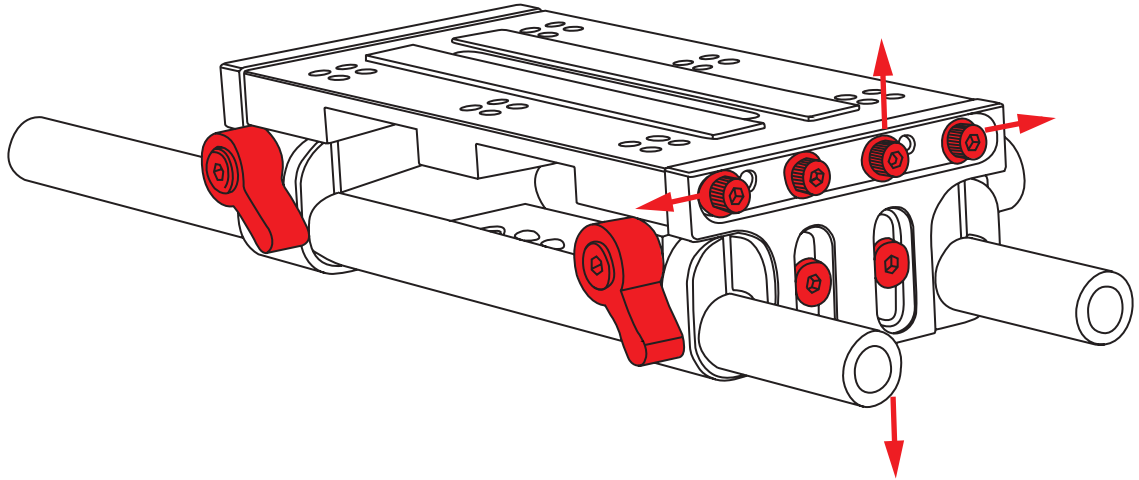

**3. Secure Large Baseplate Rods to Rod Clamp.**

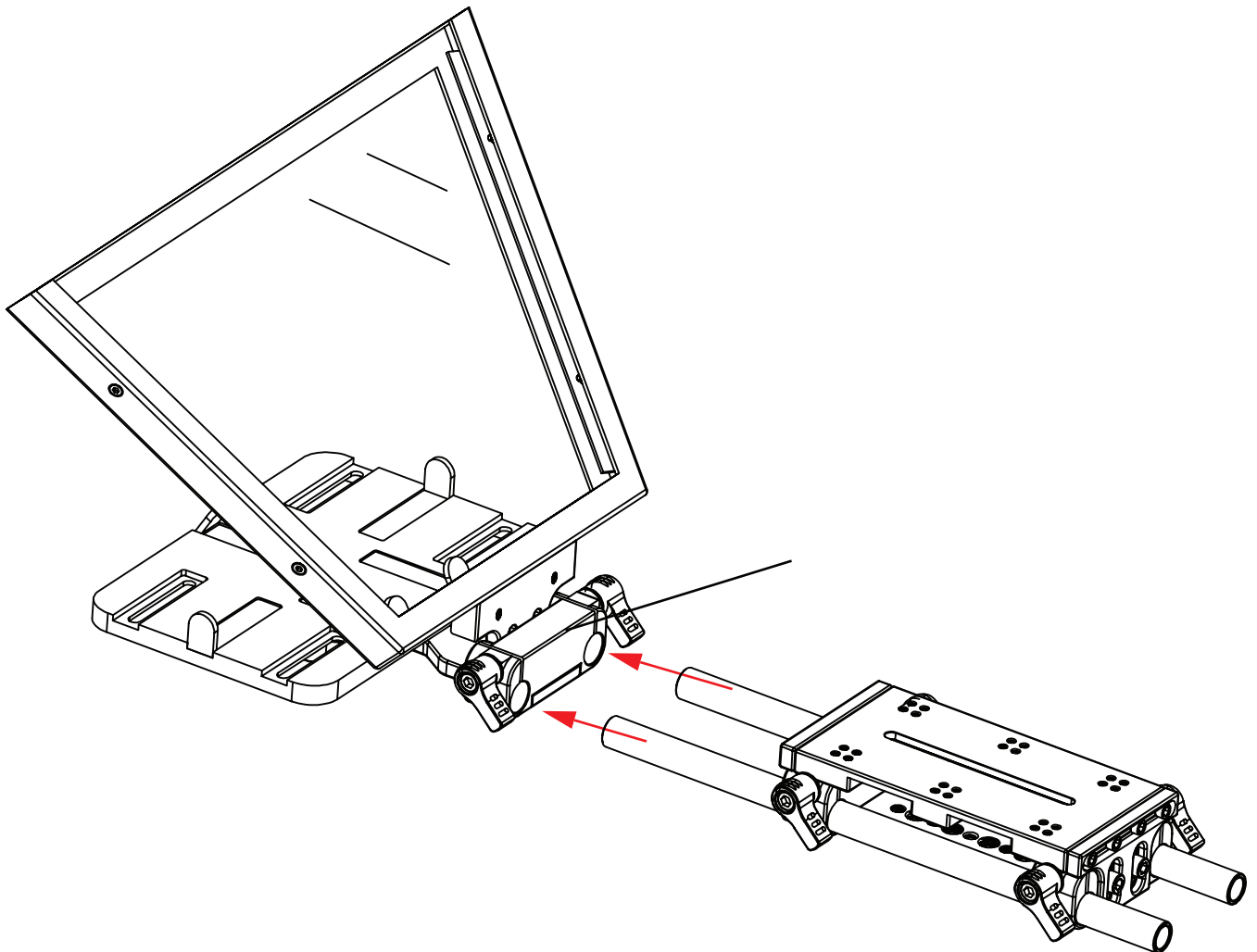

4. Attach the magnetic hood to glass frame.

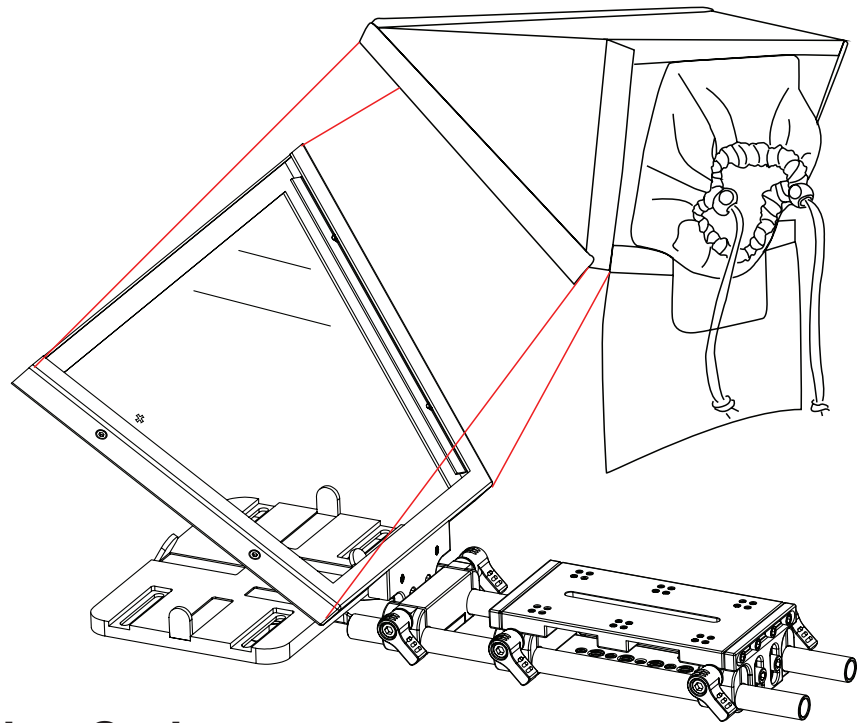

## Quick Release Mounting Options

The ikan Large Baseplate is compatible with both the Canon TA100 & ikan-WDGL Tripod Adapter Systems. Simply mount your Quick Release Plate to the bottom of the Large Baseplate component on the appropriate end, using four (4) Socket Head Countersink Screws.

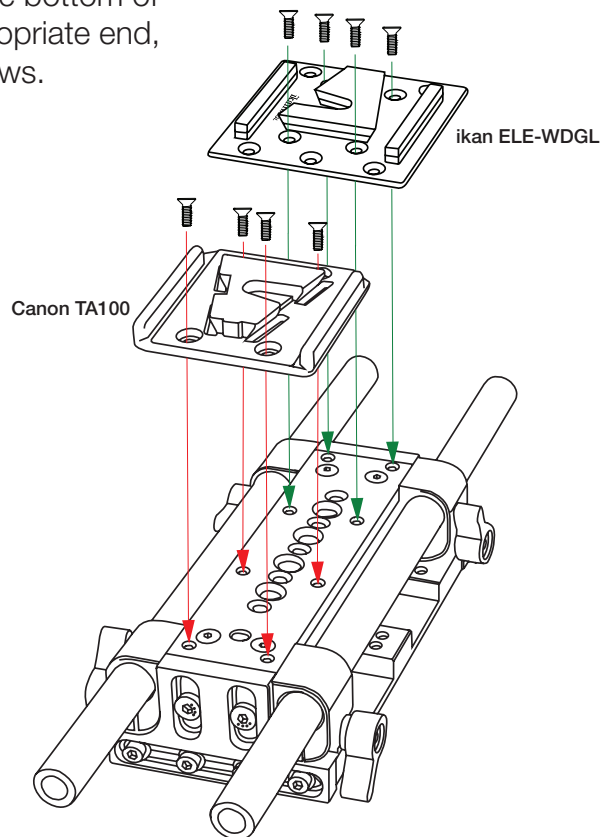

## **Learn More**

More dynamic information at official website: [www.ikancorp.com](http://www.ikancorp.com)

## **Support**

Contact email: [support@ikancorp.com](mailto:support@ikancorp.com)

### **CONDITIONS OF WARRANTY SERVICE**

- Free service for one year from the day of purchase if the problem is caused by manufacturing errors.
- The components and maintenance service fee will be charged if the warranty period is expired.

Free Service will not be Provided in the Following Situations: (\*Even if the product is still within the warranty period.)

- Damage caused by abuse or misuse, dismantling, or changes to the product not made by the company.
- Damage caused by natural disaster, abnormal voltage, and environmental factors, etc.