

OTTICA-4K



OTTICA NDI HX PTZ Video Camera 12x Optical Zoom POE 4K 60p

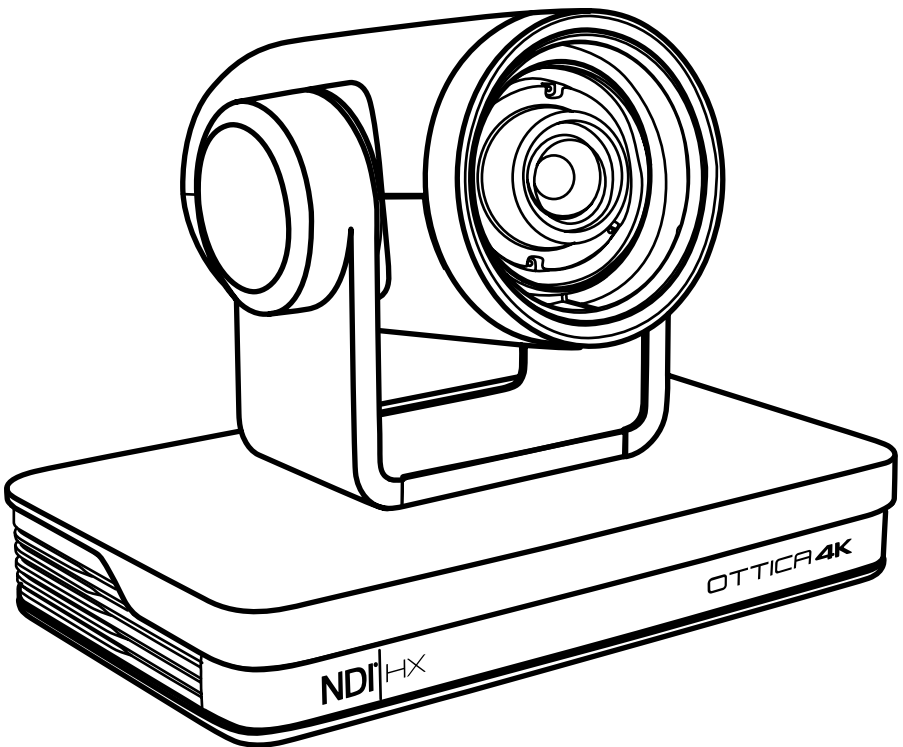

Table of Contents

1. Getting Started.....	3
1.1 Camera Interface.....	3
1.2 Power-On Initial Configuration.....	4
1.3 Video Output.....	4
1.4 Mounting Brackets.....	5
2. Product Overview.....	7
2.1 Product Introduction.....	7
2.1.1 Dimensions.....	7
2.1.2 Accessories.....	7
2.2 Main Features.....	8
2.3 Technical Specifications.....	9
2.4 Interface Instructions.....	12
2.4.1 External Interface.....	12
2.4.2 RS-232 Interface.....	12
3. Application Instructions.....	14
3.1 Video Output.....	14
3.2 Remote Control.....	14
3.2.1 Key Instructions.....	15
3.3 Menu Introduction.....	18
3.3.1 Main Menu.....	18
3.3.2 System Settings.....	18
3.3.3 Camera Settings.....	19
3.3.4 P/T/Z.....	21
3.3.5 Video Format.....	21
3.3.6 Version.....	22
3.3.7 Restore Default.....	22
4. Network Connection.....	23
4.1 Obtain Camera IP Address.....	23
4.2 IE Log In.....	24
4.2.1 Web Client.....	25
4.2.2 Preview.....	25
4.2.3 Configuration.....	25
4.2.4 Audio Configuration.....	25
4.2.5 Video Configuration.....	25
4.2.6 Network Configuration.....	29
4.2.7 System Configuration.....	30
4.2.8 Logout.....	32
5. Serial Communication Control.....	32
5.1 VISCA Protocol List.....	32
5.1.1 VISCA Protocol Return Command.....	32
5.1.2 VISCA Protocol Control Command.....	33

Table of Contents (cont.)

5.1.3 Inquiry Command	38
5.2 Pelco-D Protocol Command List	41
5.3 Pelco-P Protocol Command List	42
6. Camera Maintenance and Troubleshooting	43
6.1 Camera Maintenance	43
6.2 Troubleshooting	43

1. Getting Started

1.1 Camera Interface

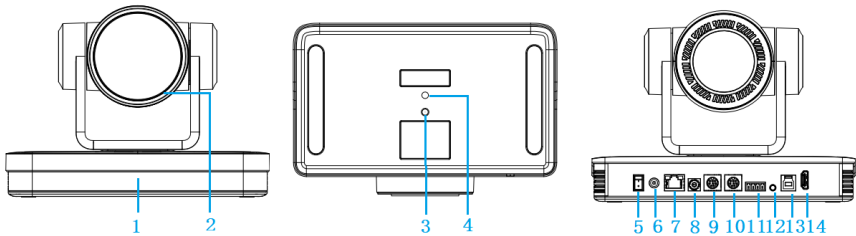

Figure 1.1 Product Interface

- | | |
|---------------------------------------|--------------------------------------|
| 1. Remote Control Receiving Indicator | 8. Rotary DIP Switch |
| 2. Camera Lens | 9. RS232 Control Interface (input) |
| 3. 1/4"-20 Screw Thread | 10. RS232 Control Interface (output) |
| 4. 1/4"-20 Screw Thread | 11. RS422/RS485 Input |
| 5. Power Switch | 12. Audio Input Interface |
| 6. DC12V Input Power Supply Socket | 13. USB 3.0 Interface |
| 7. LAN Port | 14. HDMI Output Interface |

1.2 Power-On Initial Configuration

1. Power-On: Connect the DC12V power supply adapter with the power supply socket.
2. Initial Configuration: Upon powering on, the remote control receiver light will turn on and start blinking red. The camera head will move and adjust into the HOME position (intermediate position of both horizontal and vertical). When the remote control receiver light stops blinking red, it will stay on and turn green; this means the self-checking is finished.
 - Note: After the Power-On self-test is completed If you press “set preset” then “0”, the camera head automatically moves to the preset HOME position any time you press “0”.

1.3 Video Output

The OTTICA has a variety of video outputs including LAN, HDMI and 3G-SDI.

1. Video Output from LAN

A. Network Cable Connection Port: No.12 in Figure1.1;

B. Webpage Login:

- The OTTICA-4K is set to auto DHCP so you'll need to connect the camera to devices that can automatically assign an IP address, such as routers and switches.
- Next, you'll have to use an IP scanning software to find the camera's IP address (visit the OTTICA-4K product page at www.ikancorp.com to find a link to our recommended software for IP scanning).
- Copy and paste the camera's IP address and paste it into your web browser's address bar and press “Enter” to proceed into the login page.
- Enter the user name “admin” and password “admin” (factory default) and press “Enter” to proceed into the preview page.
- If you do not have the latest version of Flash installed, click on the button that says “Get ADOBE Flash Player.”
- After you've installed the latest version of flash, the camera feed should be visible and you can now perform PTZ control, video recording, playback, configuration, and other operation.
- NOTE: See chapter 4.1 for more details.

2. HDMI Video Output

A. HDMI Video Cable Connection: Refer to No.11 in Figure1.1.

B. Connect the camera and monitor via HDMI video cable.

3. 3G-SDI Video Output

A. 3G-SDI video cable connection: Refer to No.10 in Figure1.1

B. Connect the camera and the monitor via 3G-SDI video cable

1.4 Mounting Brackets

Note: The bracket can only be mounted on a wall or ceiling on either template or concrete wall, but cannot be installed on plasterboard.

Wall Mount Steps

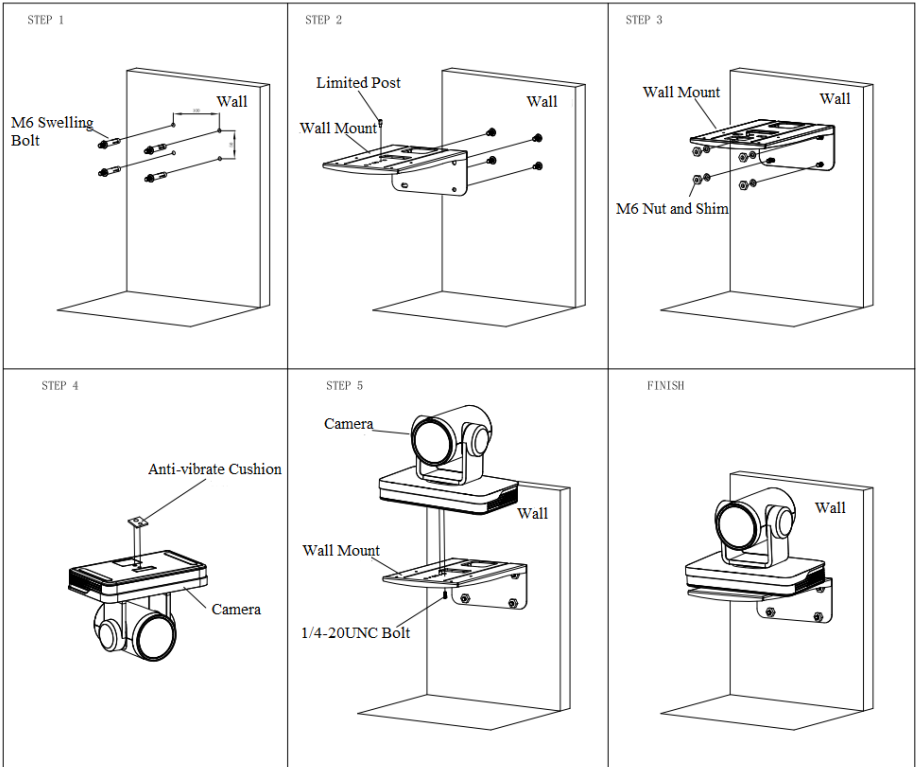
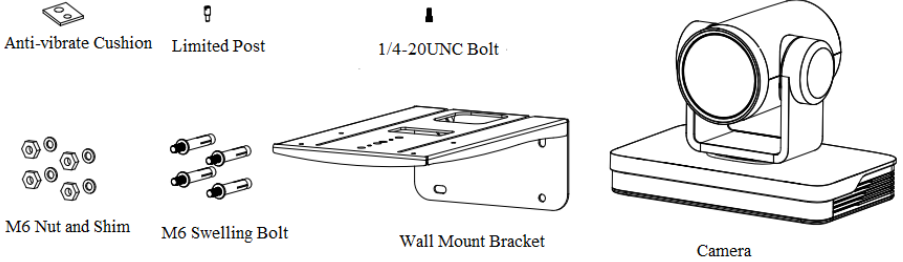

Ceiling Mount Steps

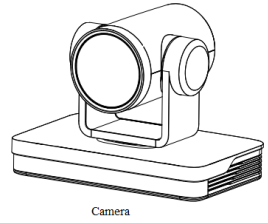
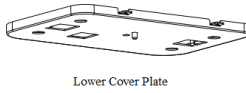
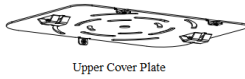

STEP 1

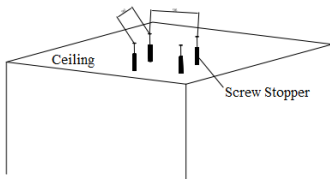

STEP 2

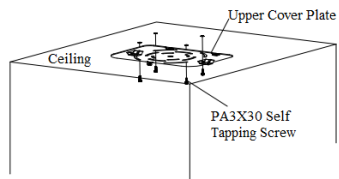

STEP 3

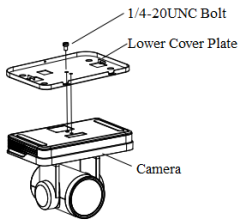

STEP 4

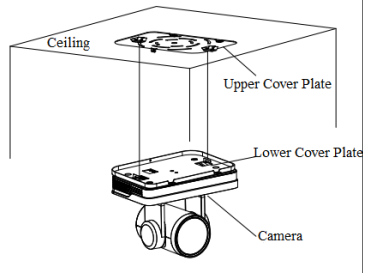

STEP 5

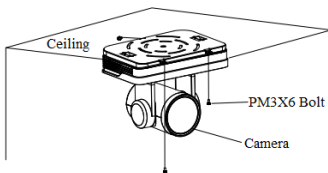

FINISH

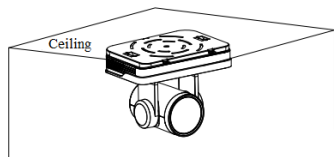

2. Product Overview

2.1 Product Introduction

2.1.1 Dimensions

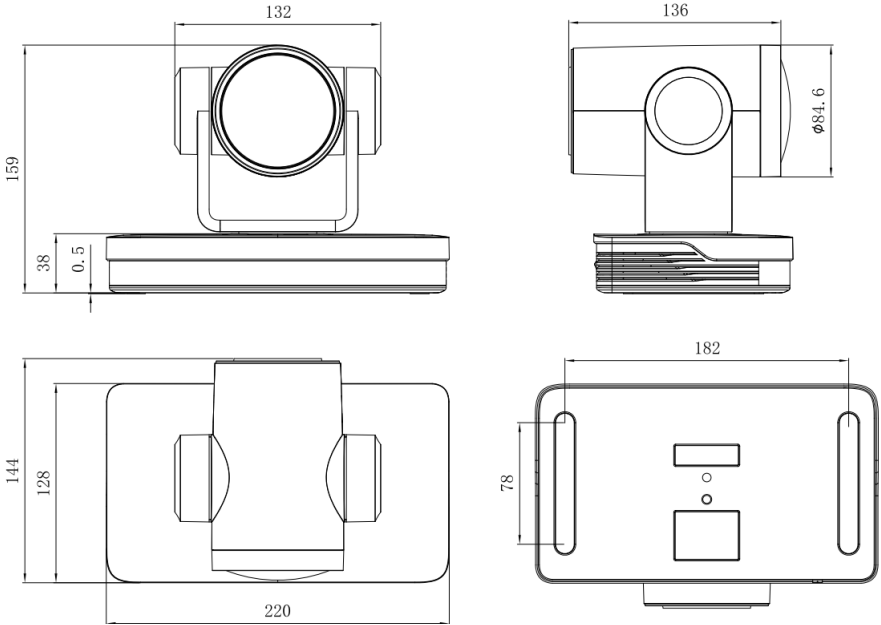

Figure 2.1 Camera Dimensions

2.1.2 Accessories

When unboxing, check that all the Standard Accessories are included:

Standard Accessories

- 1 x Power Adapter
- 1 x RS232 Cable
- 1 x IR Remote Controller
- 1 x Wall Mounting Bracket
- 1 x RS485 Connector
- 1 x Cascade Cable

Optional Accessories

- OTTICA Controller
- Ceiling Mount
- Wireless Remote Control

2.2 Main Features

The OTTICA-4K camera is a new UHD 4K camera with 12X optical zoom and a 80.4° wide angle lens. Featuring with advanced ISP processing algorithms, offering vivid and high resolution video with a strong sense of depth and fantastic color rendition.

1. 4K UHD Resolution: 1/2.5" high quality SONY CMOS sensor. Up to 4K 60fps Resolution/Frame rate.
2. Dual Stream Output: USB output can support main stream and sub stream output at the same time, and can meet the needs of near-end and far-end.
3. Optical Zoom Lens: 12X optical zoom. Wide 80.4° field of view.
4. Multi-format Video Outputs: Supports HDMI, USB 3.0, LAN, and outputs 4K audio and video simultaneously.
5. Leading Auto Focus Technology: Fast, accurate and stable auto focusing technology.
6. Low Noise and High SNR: The Low Noise CMOS effectively ensures high SNR of the camera video. Advanced 2D/3D noise reduction technology is also used to further reduce the noise, while ensuring image sharpness.
7. Multiple Audio/Video Compression Standards: LAN interface supports H.264/H.265 video compression, USB3.0 interface supports MJPG, H264, YUY2, NV12, H265; supports AAC, MP3 and G.711A audio compression, 8000, 16000, 32000, 44100, 48000 sampling frequencies.
8. Multiple Network Protocol: Supports NDI, ONVIF, GB/T28181, RTSP, RTMP protocols; Support RTMP push mode, easy to be connected to streaming server (Wowza, FMS); Support RTP multicast mode; Support network full command VISCA control protocol.
9. Control Interface: RS422 input (compatible with RS485), RS232 input/output, RS232 (cascade connection)
10. Multiple Control Protocol: VISCA, PELCO-D, PELCO-P protocols; Automatic identification protocols.
11. Multiple presets: Up to 255 presets (10 presets via remote control).
12. Multiple Application: Online-education, Lecture Capture, Webcasting, Video conferencing, Tele-medicine, Unified Communication, Emergency command and control systems, etc.

2.3 Technical Specifications

Camera Parameters	
Optical Zoom	12X; f=3.85 mm ~ 43.06 mm ±5%
View Angle	Parallel: 7.59° (N) ~ 80.4° (W) Vertical: 4.6° (N) ~ 50.0° (W)
AV	F1.8 ~ F3.56±5%
Sensor	1/2.5inch SONY CMOS sensor
Effective Pixels	8.51M megapixel 16:9
Video Format	<p>HDMI Video Format 4K@60fps/ 4K@50fps/ 4K@30fps/ 4K@25fps/ 1080P@60fps/ 1080P@50fps/ 1080I@60fps/ 1080I@50fps/ 1080P@30fps/ 1080P@25fps/ 720P@60fps/ 720P@50fps</p> <p>USB3.0 Interface Video Format YUY2/NV12: 1920×1080@30/25fps/ 1280×720@30/25fps/ 960×540@30/25fps/ 640×360@30/25fps/ 640×480@30/25fps/ 320×176@30/25fps MJPEG/H.264/H.265: 3840×2160@30/25fps/ 1920×1080@30/25fps/ 1280×720@30/25fps/ 960×540@30/25fps/ 640×360@30/ 25fps/640×480@30/25fps/ 320×176@30/25fps</p> <p>USB3.0 is Compatible with USB2.0 Video Format YUY2/NV12: 640×360@30/25fps/ 640×480@30/25fps/ 320×176@30/25fps MJPEG/H.264/H265: 3840×2160@30/25fps/ 1920×1080@30/25fps/ 1280×720@30/25fps/ 960×540@30/25fps/ 640×360@30/25fps/ 640×480@30/25fps/ 320×176@30/25fps</p>
Minimum Illumination	0.05Lux(F1.8, AGC ON)
DNR	2D&3D DNR
White Balance	Auto / Manual / One Push/ Specify Color Temperature
Focus	Auto / Manual / One Push Focus

Camera Parameters	
Exposure Mode	Auto/Manual / Shutter priority / Aperture Priority / Brightness Priority
Aperture	F1.8 - F11
Shutter Speed	1/25 - 1/10000
BLC	ON/OFF
WDR	OFF/ Dynamic Level Adjustment
Video Adjustment	Brightness, Color, Saturation, Contrast, Sharpness, B/W Mode, Gamma Curve
SNR	≥50dB

Input / Output Interface	
Video Interfaces	HDMI, LAN (POE), USB3.0 (Type-B compatible with USB2.0, A-IN, RS232-IN, RS232-OUT, RS422 (compatible with RS485), Rotary DIP switch, DC12V Power Supply, Power Switch
Video Compression Format	LAN Interface: H.264, H.265 USB 3.0 Interface: MJPG, H264, YUY2, NV12, H265
Audio Input Interface	Double track 3.5mm linear input
Audio Output Interface	HDMI, LAN, USB3.0
Audio Compression Format	AAC, MP3, G.711A
Network Interface	10M/100M/1000M Adaptive Ethernet port, support POE power supply, support audio and video output
Network Protocols	NDI ,RTSP, RTMP, ONVIF, GB/T28181; Network VISCA control protocol: Support remote upgrade, reboot and reset
Control Interface	RS232-IN,RS232-OUT, RS422 compatible with RS485
Serial Communication Protocol	VISCA/PELCO-D/PELCO-P Baud Rate: 115200/38400/9600/4800/2400
USB Communication Protocol	UVC (Video), UAC (Audio)
Power Interface	HEC3800 outlet (DC12V)
Supply Adapter	AC110V~AC220V to DC12V/2.5A

Input / Output Interface	
Input Voltage	DC12V±10%
Input Current	<1A
Power Consumption	<12W

PTZ Parameters	
Pan Rotation	-110° ~ +110°
Tilt Rotation	-30° ~ +30°
Pan Control Speed	0.1 -100°/sec
Tilt Control Speed	0.1-70°/sec
Preset Speed	Pan: 78.8°/s, Tilt: 31.7°/s
Preset Number	255 presets (10 presets via Remote Control)

Other Parameters	
Stored Temperature	-10°C ~ +60°C
Storage Humidity	20% ~ 95%
Working Temperature	-10°C ~ +50°C
Working Humidity	20% ~ 80%
Dimension	220mm (L) x 144mm (W) x 159mm (H)
Weight	1.7kg
Application	Indoor

2.4 Interface Instructions

2.4.1 External Interface

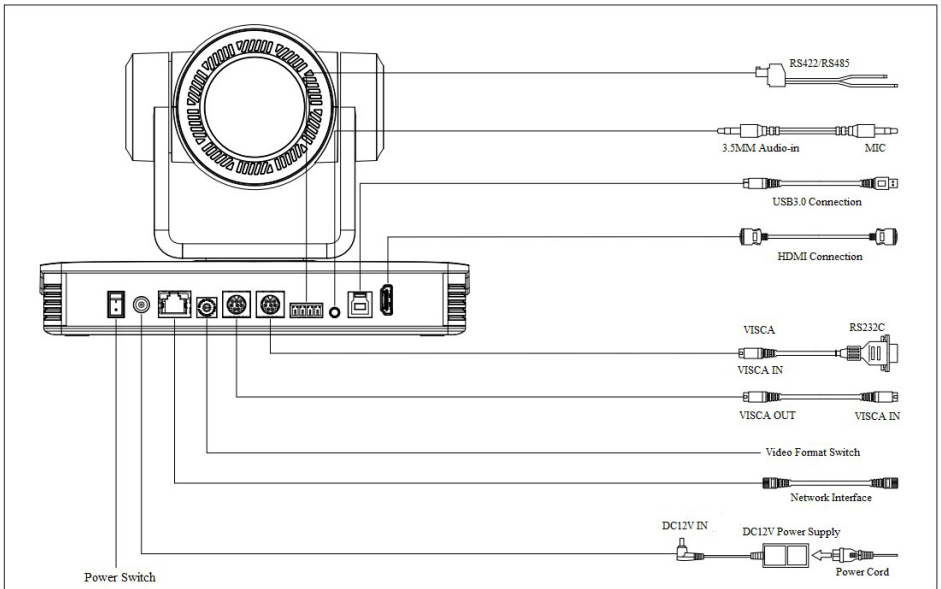
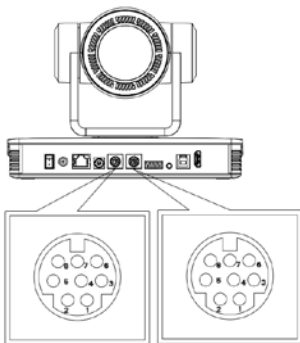

Figure 2.5 Wiring Diagram

2.4.2 RS-232 Interface

1. RS-232 Interface Definition



Computer / Keyboard & Camera Connection Method	
Camera	Windows DB-9
1. DTR	1. DCD
2. DSR	2. RXD
3. TXD	3. TXD
4. GND	4. DTR
5. RXD	5. GND
6. GND	6. DSR
7. IR OUT	7. RTS
8. NC	8. CTS
	9. RI

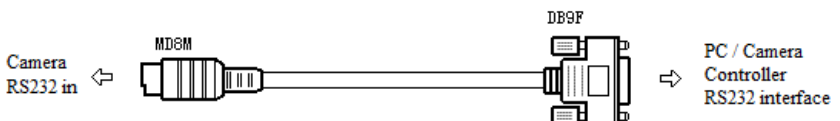

2. RS-232 Mini-DIN 8-pin Port Definition

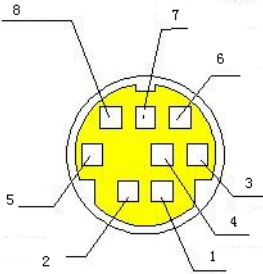

No.	Port	Definition
1	DTR	Data Terminal Ready
2	DSR	Data Set Ready
3	TXD	Transmit Data
4	GND	System Ground
5	RXD	Receive Data
6	GND	System Ground
7	IR OUT	IR Commander Signal
8	NC	No Connection

3. RS232 (DB9) Port Definition

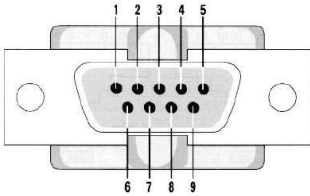

No.	Port	Definition
1	DCD	Data Carrier Detect
2	RXD	Receive Data
3	TXD	Transmit Data
4	DTR	Data Terminal Ready
5	GND	System Ground
6	DSR	Data Set Ready
7	RTS	Request to Send
8	CTS	Clear to Send
9	RI	Ring Indicator

4. VISCA Networking:

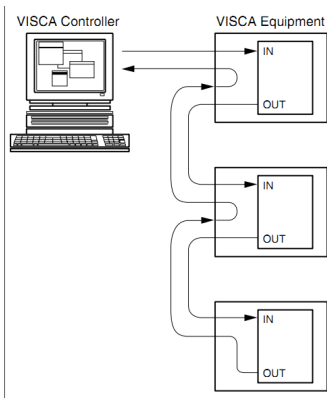

Camera Cascade Connection Method	
Camera 1	Camera 2
1. DTR	1. DTR
2. DSR	2. DSR
3. TXD	3. TXD
4. GND	4. GND
5. RXD	5. RXD
6. GND	6. GND
7. IR OUT	7. OPEN
8. NC	8. OPEN

Note: OTTICA-4K has RS232 input and output interface, so you can cascade as shown above.

3. Application Instructions

3.1 Video Output

Connect to the video output cable: the user can refer to Figure 1.1 product interfaces.

1. Network Output: Upon powering on, the remote control receiver light will turn on and start blinking red. The camera head will move and adjust into the HOME position (intermediate position of both horizontal and vertical). When the remote control receiver light stops blinking red, it will stay on and turn green; this means the self-checking is finished.
2. HDMI output: Connect the monitor with the corresponding video output interface.
3. USB3.0 output: Connect the camera to the computer with the USB3.0 interface (blue cable), open the Device Manager to see whether there is an imaging device and whether the Universal Serial Bus controllers recognize the USB3.0 device. After properly identified, open the software, choose the imaging device, and then it will output the image.

3.2 Remote Control

One to One Code Matching:

- Press the “set” and “*” keys combined for 3 seconds, the LED indicator will start flashing. The indicator will go off if the code matches successfully. The camera can be controlled by this wireless remote control only after one to one code pairing. Otherwise please clear the code matching of this remote control, or use another remote control to pair with the camera again.
- If one to one code matching has failed, the red LED light flashes for 20 seconds and then goes off and the camera will stop code matching and commence sleep mode. Press any key to wake up the camera and re-match code.

Note: After code matching is successful, please select the camera address to control it.

Clear Code:

- Press the “set” and “*” keys combined for 3 seconds. The LED indicator will start flashing. The camera will power off and on and the LED indicator will turn off if the clear code is successful.

Sleep Mode and Wake Up:

- Press any key to wake up the camera from sleep mode.



3.2.1 Key Instructions

1. Standby Key
After a 3-second long press, the camera will step into standby mode. After pressing the standby key for 3 seconds again, the camera will self-test again and go back to the HOME position.
2. Camera Address Selection
Select the camera address to be controlled.
3. Number Keys
Set or run 0-9 presets.
3. # + * Keys
Use for key combinations.
5. Focus Control Key
Auto Focus: Enter into auto focus mode.
Manual Focus: The camera focus mode is manual
Switch the camera focus mode to manual focus by pressing [focus +] or [focus -] to adjust.
6. Zoom Control Key
Zoom +: Zoom In.
Zoom -: Zoom Out.
7. Set or Clear Preset key:
Set Preset: Sets preset key + 0-9 number key.
Clear Preset: Clears preset key + 0-9 number key.
8. Pan/Tilt Control Key
Press Key: Tilts camera upwards.
Press Key: Tilts camera downwards.
Press Key: Pans camera left.
Press Key: Pans camera right.
"HOME" Key: Returns camera to the middle position. Also used to enter into the next level menu.
9. BLC Control Key
Back Light ON / OFF: Turn on or off the back light.
10. Menu Setting
Open or close the on-screen-display menu.
Enter / exit the on-screen-display menu or return to the previous menu.

11. Camera IR Remote Control Address Setting

- [*]+ [#]+[F1] : Camera Address No. 1
- [*]+ [#]+[F2] : Camera Address No. 2
- [*]+ [#]+[F3] : Camera Address No. 3
- [*]+ [#]+[F4] : Camera Address No. 4

12. Key Combination Functions

[#] + [#] + [#]: Clear all presets	[*] + [#] + [6]: Restore factory defaults
[*] + [#] + [9]: Flip switch	[*] + [#] + Auto: Enter into the aging mode
[*] + [#] + [3]: Menu set to Chinese	[*] + [#] + [4]: Menu set to English
[*] + [#] + Manual: Restore the default user name, password, and IP address	[#] + [#] + [0]: Switch video format to 1080p60
[#] + [#] + [1]: Switch video format to 1080p50	[#] + [#] + [2]: Switch video format to 1080i60
[#] + [#] + [3]: Switch video format to 1080i50	[#] + [#] + [4]: Switch video format to 720p60
[#] + [#] + [5]: Switch video format to 720p50	[#] + [#] + [6]: Switch video format to 1080p30
[#] + [#] + [7]: Switch video format to 1080p25	[#] + [#] + [8]: Switch video format to 720p30
[#] + [#] + [9]: Switch video format to 720p25	

Users can control the pan/tilt/zoom, settings and execute preset positions via the IR remote control.

Key Instructions:

- In these instructions, “press the key” means a click rather than a long-press. A special note will be given if a long-press for more than one second is required.
- When a key-combination is required, do it in sequence. For example, “[*] + [#] + [F1]” means press [*] first, then press [#], lastly press { F1 }



Camera Selection

- Select the camera address to control.

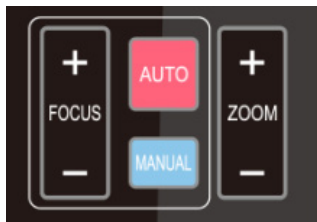

Focus Control

- Focus (near): Press FOCUS + Key
(Valid only in manual focus mode)
- Focus (far): Press FOCUS - Key
(Valid only in manual focus mode)
- Pressing and holding the "+" or "-" keys will result in the action of focus to continue. Release the key to stop the action of focus.
- Auto Focus: Enables auto focus function.
- Manual Focus: Enables manual focus function.

Zoom Control

- ZOOM IN: Press Zoom + Key
- ZOOM OUT: Press Zoom - Key
- By pressing and holding the key, the camera lens will keep zooming in or zooming out and stops as soon as the key is released.



Preset Setting

- To set a preset position, press the [SET PRESET] key first and then press the number key 0-9 to set a relative preset.
- Note: 10 preset positions in total are available by remote control.

Preset Running

- Press a number key 0-9 directly to run a relative preset.
- Note: Action will not be completed if a relative preset position doesn't exist.

Preset Clearing

- To clear a preset position, press the [CLEAR PRESET] key first and then press the number key 0-9 to clear the relative preset.
- Note: press the [#] key three times to clear all presets.



Pan/Tilt Control

- Up: Press Down: Press
- Left: Press Right: Press
- Back to middle position: Press HOME
- Press and hold the up/down/left/right key to pan or tilt the camera. The camera movement will ease from slow to fast until it reaches the endpoint. The pan/tilt movement stops as soon as the key is released.



BLC ON / OFF

- Enables and/or disables backlight compensation

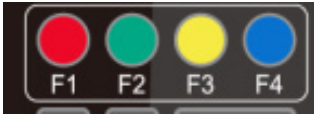

Remote Control Address Setting

- [*]+ [#]+[F1] : Camera Address No. 1
- [*]+ [#]+[F2] : Camera Address No. 2
- [*]+ [#]+[F3] : Camera Address No. 3
- [*]+ [#]+[F4] : Camera Address No. 4

3.3 Menu Introduction

3.3.1 Main Menu

In normal working mode, press the MENU key to display the menu. Use the scroll arrow to point at or highlight the selected items.

MENU

=====

Language	English
----------	---------

(Setup)
(Camera)
(P/T/Z)
(Video Format)
(Version)
(Restore Default)

[↑ ↓] Select [← →] Change Value
[MENU] Back [HOME] OK

[MENU] Back: Press MENU to Return
[HOME] OK: Press HOME to Confirm
Language Setting: English / Chinese
Setup: System Settings
Camera: Camera Parameter Settings
PTZ: Pan / Tilt / Zoom Settings
Video Format: Resolution & Frame Rate
Version: Camera Version Information
Restore Default: Reset All Settings

[↑ ↓] Select: Menu Selection
[← →] Change Value: Modify Parameters

3.3.2 System Settings

Move the arrow to the SETUP option in the Main Menu and click the HOME key to enter into the SETUP Settings Menu.

SETUP

=====

Protocol	Auto
Visca Address	1
Visca Address Fix	OFF
PELCO-P Address	1
PELCO-D Address	0
Baud Rate	9600
Auto Flip	OFF

[↑ ↓] Select [← →] Change Value

Protocol: VISCA / PELCO-P / PELCO-D/ AUTO
Visca ADDR: VISCA = 1~7
 PELCO-P = 1~255
 PELCO-D = 1~255
Visca Address Fix: ON / OFF
Baud Rate: 2400 / 4800 / 9600 / 115200
Auto Flip: ON / OFF

3.3.3 Camera Settings

Move the arrow to the CAMERA option in the Main Menu and click the HOME key to enter into the CAMERA Settings Menu.

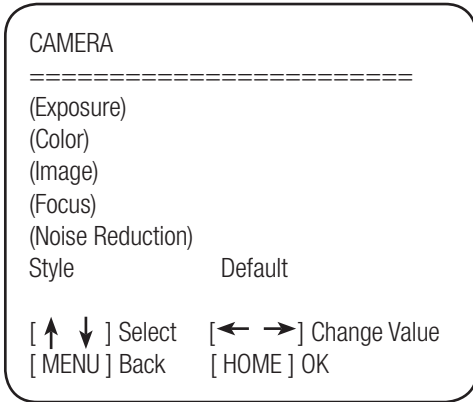

Move the arrow to desired setting (Exposure, Color, etc.) option in the CAMERA menu and click the HOME key to enter.

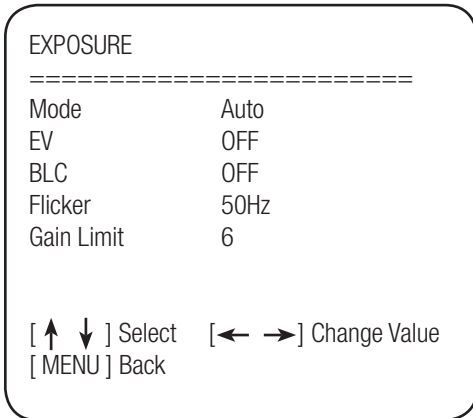

1. EXPOSURE

- Mode: Auto / Manual / Shutter Priority / Iris Priority / Brightness Priority
- EV: ON / OFF (Only available in Auto mode)
- Compensation Level: -7~7 (only available in auto mode when EV is ON)
- BLC: ON/OFF for options (only available in auto mode)
- Flicker: OFF/50Hz/60Hz for options (only available in Auto/Iris priority/Brightness priority modes)

- Gain Limit: 0~15(only available in Auto/ Iris Priority /Brightness Priority mode)
- Shutter Priority: 1/25, 1/30, 1/50, 1/60, 1/90, 1/100, 1/120, 1/180, 1/250, 1/350, 1/500, 1/1000, 1/2000, 1/3000, 1/4000, 1/6000, 1/10000 (only available in Manual and Shutter priority mode)
- IRIS Priority: OFF, F11.0, F9.6, F8.0, F6.8, F5.6, F4.8, F4.0, F3.4, F2.8, F2.4, F2.0, F1.8 (only available in Manual and Iris priority mode)
- Brightness: 0~23 (only available in Brightness Priority mode)

COLOR

=====

WB Mode	Auto
RG Tuning	-10
BG Tuning	-10
Saturation	100%
Hue	7
AWB Sensitivity	High

[↑ ↓] Select [← →] Change Value
[MENU] Back

2. COLOR

- WB Mode: Auto, 3000K, 3500K, 4000K, 4500K, 5000K, 5500K, 6000K, 500K, 7000K, Manual, One Push
- RG Tuning: -10 ~ 10
(only available in Automatic mode)
- BG Tuning: -10 ~ 10
(only available in Automatic mode)
- Red Gain: 0~255
(only available in Manual Mode)
- Blue Gain: 0~255
(only available in Manual Mode)
- Saturation: 60% ~ 200%
(in increments of 10%)
- Hue 0 ~ 14
- AWB Sensitivity: High/Middle/Low

IMAGE

=====

Brightness	7
Contrast	7
Sharpness	6
Flip-H	OFF
Flip-V	OFF
B&W-Mode	Color
Gamma	Default
DZoom	OFF
DCI	Close
Low-Light Mode	Close

[↑ ↓] Select [← →] Change Value
[MENU] Back

3. IMAGE

- Brightness: 0~14
- Contrast: 0~14
- Sharpness: 0~15
- Flip Horizontal: On/Off
- Flip Vertical: On/Off
- B&W Mode: Color, Black/White
- Gamma: default, 0.45, 0.50, 0.55, 0.63
- Digital Zoom Options: On/Off
- Dynamic Contrast: Off, 1~8
- Low-Light Mode: On/Off

FOCUS

=====

Focus Mode	Auto
AF-Zone	Center
AF-Sensitivity	Low

[↑ ↓] Select [← →] Change Value
[MENU] Back

4. FOCUS

- Focus Mode: Auto, Manual
- AF-Zone: Up, Middle, Down
- AF-Sensitivity: High, Middle, Low

NOISE REDUCTION

=====
NR-2D 3
NR-3D 3
Dynamic Hot Pixel 3

[↑ ↓] Select [← →] Change Value
[MENU] Back

4. NOISE REDUCTION

- 2D Noise Reduction: Auto, Close, 1~7
- 3D Noise Reduction: Close, 1~8
- Dynamic Hot Pixel: Close, 1~5 Auto, Close, 1~7

3.3.4 P/T/Z

Move the arrow to the P/T/Z option in the Main Menu and click the HOME key to enter into the P/T/Z Settings Menu.

P/T/Z

=====
Depth of Field ON
Zoom Speed 5
Image Freezing OFF
Acc Curve Slow

[↑ ↓] Select [← →] Change Value
[MENU] Back

- Speed by Zoom: Only effective for remote controller, On/Off;
- When zooming in, the PT control speed by remote will become slow)
- Zoom Speed: Set the zoom speed for remote controller, 1~8
- Image Freezing: On/Off
- Accelerating Curve: Fast/slow

3.3.5 Video Format

Move the arrow to the VIDEO FORMAT option in the Main Menu and click the HOME key to enter into the VIDEO FORMAT Settings Menu.

VIDEO FORMAT

=====
4KP60 4KP50
4KP30 4KP25
1080P60 1080P50
1080I60 1080I50
720P60 720P50

[↑ ↓] Select
[MENU] Back [HOME] OK

- Exiting the menu will save the modification of the parameter. Restart device for parameter modification to be enabled.

3.3.6 Version

Move the arrow to the VERSION option in the Main Menu and click the HOME key to enter into the VERSION Settings Menu.

VERSION		
=====		
MCU Version	3.1.0	2019-11-23
Camera Version	1.0.0	2019-12-4
AF Version	1.0.0	2019-08-20

- MCU Version: Display MCU version information
- Camera Version: Display camera version information
- AF Version: Display the focus version information

3.3.7 Restore Default

Move the arrow to the RESTORE DEFAULT option in the Main Menu and click the HOME key to enter into the RESTORE DEFAULT Settings Menu.

RESTORE DEFAULT	
=====	
Restore Default?	NO
[↑ ↓] Select	[← →] Change Value
[MENU] Back	[HOME] OK

- Restore default: Yes/No; (Color Style and Video Format cannot be restored to factory default.)
- Note: If the address of former remote is 2, 3, or 4, the corresponding camera address will restore to 1 when all parameters or system parameters are restored. User should change the remote address to be 1 (press No.1 according to the camera to get normal operation)

4. Network Connection

4.1 Obtain Camera IP Address

The OTTICA is set to Auto DHCP, so you'll need to obtain camera IP address before connecting to a network. See 2 common solutions to obtain the camera IP address.

Solution 1:

1. Connect the camera to a device that can automatically assign an IP address, such as routers and switches.
2. Use an IP Search Tool to search LAN segment, such as "192.168.5.0~192.168.5.255". We suggest using "SoftPerfect Network Scanner" or "Advanced IP Scanner" software to get the search results.
3. Then search the results and refer to the MAC address pasted on the bottom of the camera to obtain the camera IP address.

Reference Image:

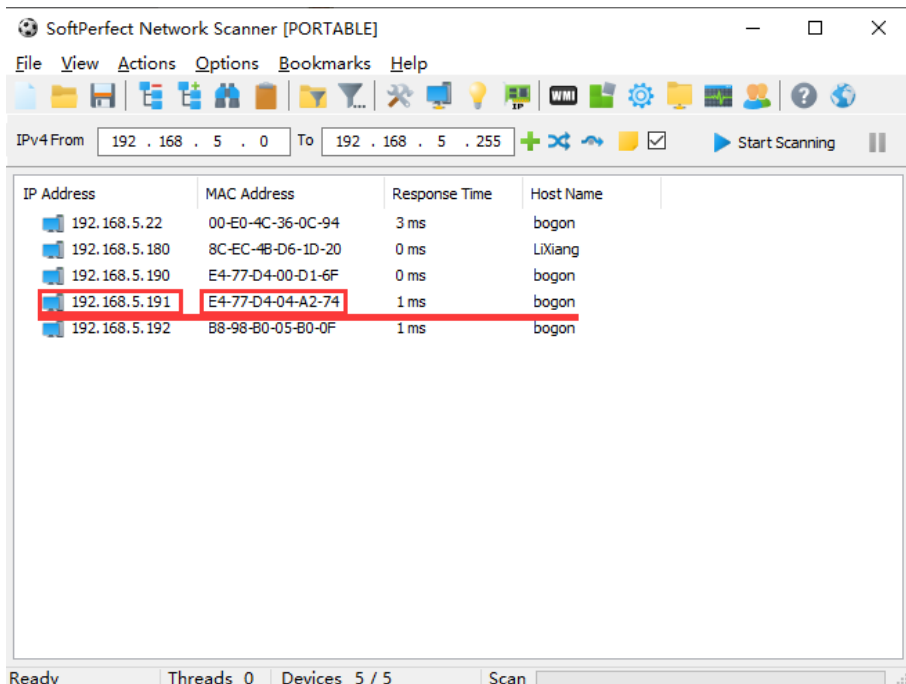

Solution 2:

1. Connect the camera to devices that can automatically assign IP address, such as routers and switches.
2. Enter into the Management Interface of the router or switch and obtain the camera IP address with reference to the MAC address pasted on the bottom of the camera.

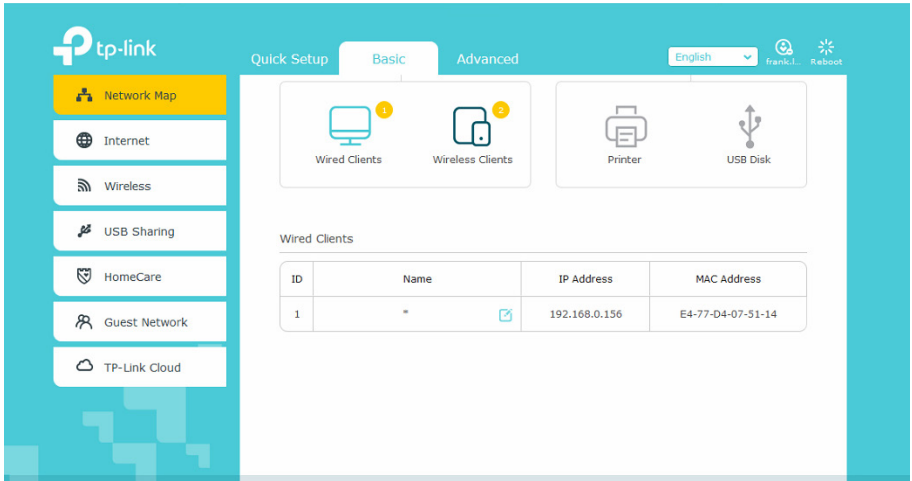

4.2 IE Log In

4.2.1 Web Client

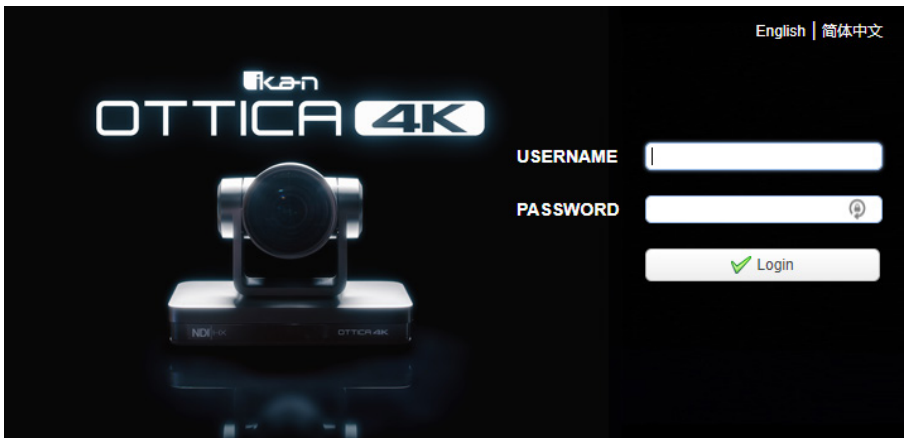

Web Client Log In

- Input the camera IP address (the IP address you obtain through Search Tool) in the address field of your browser and click the "Enter" button to proceed to the Web Client login page.

- You can login as the administrator and normal user. If logging in as an administrator, fill out the required fields with the following: Username: admin. Password: admin.
- Users can preview, playback, cancel, and configure in the Web Client; If logging in as a normal user, the default User name/Password is: user1 or user2. Users can only preview playback and cancel. There is no option for configuration.
- The camera's video feed should be visible and you can now perform PTZ control, video recording, playback, configuration, and other operations.

4.2.2 Preview

- After successfully logging into the management interface, the video preview interface will become visible. In this interface, users can control pan, tilt, zoom, focus, video capture, sound, full screen, set the preset position, run, delete, and other operations.

Note: There are no configuration rights for normal user login. To access the configurations menu, you will need to login as Username: admin / Password: admin

4.2.3 Configuration

- Click Configuration to enter into the settings page.
- There are the following options: Audio Configuration, Video Configuration, Network Configuration, System Configuration.

4.2.4 Audio Configuration

- Switch: Choose to enable the audio or not.
- Encoding Type: Set the audio compressing format and the device will reboot automatically after the change (default: AAC. optional: G.711A & MP3).
- Sample Rate: Set the sampling frequency and the device will reboot automatically after change (default: 48000; optional: 16000, 32000, 44100) (G.711A default: 8000)
- Sampling Bits: Set the sampling precision (Default: 16bits)
- Bit Rate: Set the audio compressing code rate (Default: 64kbps; Optional: 32, 48, 96, 128kbps)
- Input Volume: Set the volume level (default: 2; Optional: 1-10).

Note: Click "SAVE" and restart the device to enable the new settings.

4.2.5 Video Configuration

1. Video Encoding

- Compression Format: Set the video compression format (main / secondary stream default: H.264. H.265 is optional)
- Profile: Profile Mode Setting (default is set to HP. BP & MP are optional)
- Video Resolution: Set video image resolution (main stream default 1920x1080. 3840x2160, 2592x1944, 2304x1296, 1920x1080,1280x720 are optional; default secondary stream 320*180. 640x360, 320x240, 640x480, 320x180, 1280x720 are optional)

- Rate Control: Set rate control mode (main / secondary stream default variable bit rate, fixed rate is for option).
- Image Quality: Set the image quality, image quality can be changed only when rate control is variable bit rate.(main stream defaulted is better, secondary stream default is not good, there are best, better, good, bad, worse, worst for options).
- Bit Rate (kbs): Set the video bit rate (main stream default 8192b/s. 64-40960Kb/s are optional; secondary stream default 512Kb/s. 64-40960Kb/s are optional).
- Frame Rate (fps): Set the video frame rate (main/ secondary stream default 25fps. main stream 5-60fps are optional, secondary stream 5-30fps are optional).
- Frame Interval: Set the key frame interval (main / secondary stream default 100. main stream 1-300F optional. secondary stream 1-150F optional).
- Frame Min QP: Set the key frame minimum QP (default 20)
- Stream Name: When streaming via RTSP or RTMP , user can modify stream name. Main Stream (live/av0), secondary stream (live/av1)
- Click the “Save” button to display the “saved successfully” message. The new settings will then be activated.

2. Stream Publish

- Switch: Turn on/off the main / secondary stream.
- Protocol Type: Primary / secondary stream applies RTMP protocol.
- Host Address: Server IP addresses (Default: 192.168.5.11)
- Host Port: Server port number (Default 1935: Optional: 0-65535)
- Stream Name: Choose a different stream name (live / av0, live / av1 optional).
- User Name: Set the user name.
- Password: Set the password.
- Click on the “Save” button to display the “Save successful” message. The new settings will then be activated.
- Method of obtaining RTSP: rtsp: // device IP address: 554 / live / av0 (av0 main stream; av1 secondary stream).

3. RTP Multicast

- Main/Sub Stream: On/Off
- Protocol: RTP or TS
- Address: Default 224.1.2.3. It can be edited.
- Port: Main Stream Default Port: 4000, Sub Stream Default Port: 4002
- Visit: Address comes up after setting. Eg; rtp: //224.1.2.3:4000; udp: //@224.1.2.3:4000

4. Video Parameters

A. Focus Settings

- Focus Mode: Auto (default); Manual (optional)
- Focus range: Middle (default); Upper, Lower (optional)
- Focus Sensitivity: Low (default), High, Medium (optional)

B. Exposure

- Mode: Automatic (default), Manual, Shutter Priority (SAE), Aperture Priority (AAE), Brightness Priority.
- EV: Off (default), On (optional) Settings activated when Exposure Mode is set to Auto
- EV Value: 0 (default) -7 through 7 (optional); Settings activated when Exposure Mode is set to Auto
- BLC: Black Light Compensation Settings are activated only when Exposure Mode is set to Automatic (Default: OFF).
- Flicker: Anti-flicker settings are activated only when Exposure Mode is set to Automatic (Default: 50Hz. Optional: Off & 60Hz).
- Gain Limit: Gain limit setting are activated only when status is set to AAE or Brightness Priority (Default: 4; Optional: 0-15).
- Dynamic Range: (Default: 4; Optional: 1-8).
- Shutter Speed: Settings are activated only when Exposure Mode is set to Manual or Shutter-Priority (Default: 1/100. Optional: 1/25, 1/30, 1/50, 1/60, 1/90, 1/100, 1/120, 1/180, 1/250, 1/350, 1/500, 1/1000, 1/2000, 1/3000, 1/4000, 1/6000, 1/10000).
- Iris: Settings are activated only when Exposure Mode is set to Manual or AAE (Default: F1.8; Optional: Closed, F11, F9.6, F8.0, F6.8, F5.6, F4.8, F4.0, F3.4, F2.8, F2.4, and F2.0).
- Brightness: Settings are activated only when Exposure Mode is set to Brightness Priority (Default: 7; Optional: 0-23).

C. Color

- White Balance Mode: (Default: Automatic; Optional: 3000K, 3500K, 4000K, 4500K, 5000K, 5500K, 6500K, 7000K, Manual, One-push)
Note: Click the "Correction" button when selecting the One-push white balance mode.
- RG Tuning: Red Gain Tuning settings are activated only when WB mode is set to Automatic (Default: -10; Optional: -9~10)
- BG Tuning: Blue Gain Tuning settings are activated only when WB mode is set to Automatic (Default: -10; Optional: -9~10)
- Saturation: (Default: 60%; Optional: 70%, 80%, 90%, 100%, 110%, 120%, 130%, 140%, 150%, 160%, 170%, 180%, 190%, 200%).
- Auto White Balance Sensitivity: (Default: Low; Optional: High & Medium).
- Chroma: (Default: 7; Optional: 0-14).
- Red Gain: Red Gain settings are activated only when WB mode is set to Manual (Default: 255; Optional: 0-255).
- Blue Gain: Blue Gain settings are activated only when WB mode is set to Manual (Default: 199; Optional: 0-255).
- AWB Sensitivity: (Default: High; Optional: Low & Medium)

D. Image

- Brightness: (Default: 7; Optional: 0-14).
- Contrast: (Default: 7; Optional: 0-14).
- Sharpness: (Default: 6; Optional: 0-15).

- Gamma: (Default: 0.45; Optional: 0.50, 0.55, 0.63).
- DCI (Dynamic Contrast): (Default: OFF; Optional: 1-8)
- Black and White Mode: (Default: Color; Optional: Black &White).
- Auto Flip: (Default: OFF; Optional: ON)
- Flip Horizontal: (Default: OFF; Optional: ON)
- Flip Vertical: (Default: OFF; Optional: ON).
- DZoom (Digital Zoom): (Default: OFF; Optional: ON).

E. Noise Reduction

- 2D Noise Reduction: (Default: AUTO; Optional: 1-7 and OFF).
- 3D Noise Reduction: (Default: 5; Optional: 1-8 and OFF).
- Dynamic Dead Pixel Correction: (Default: OFF; Optional: 1-5).

Note: Click "Refresh" to make revision of any video parameters of a, b, c, d, e effective.

4. Character-Overlapping

- Display Date and Time: Set whether to display the time and date (default display).
- Display Title: Set whether to display the title (default display).
- Font Color of Time: (Default: White; Optional: Black, Yellow, Red, Blue).
- Font Color of Title: (Default: White; Optional: Black, Yellow, Red, Blue).
- Moving Characters: You can set the display position of moving date, time and title, click on the "Up, Down, Left, Right" buttons to move the corresponding character position.
- Title Content: You can set Title Content (default is set to CAMERA1).
- Time Content: You can set Time Content (default is set to 1970/01/10 05:36:00).
- After clicking on the "Save" button, the "Save Successful" message will be displayed. Your selected time settings will now be visible.

5. Character Size

- Main stream character size: Set the character size of the display, the device will restart automatically after changed and saved (Default: 48; Optional: 28-200).
- Secondary stream character size: You can set the Character Size on the display. The device will restart automatically after changed and saved (Default: 48; Optional: 28-200).
- After clicking on the "Save" button, the configuration will be validated when you see the "Parameter Saved Successfully" message displayed.

6. Video Output

- Output formats: 3840x2160P60, 3840x2160P50, 3840x2160P30, 3840x2160P25, 1080P60, 1080P50, 1080P30, 1080P25, 1080I60, 1080I50, 720P60, 720P50
- Click on the "Save" button to enable video output resolution & frame rate.

4.2.6 Network Configuration

1. Network Port

- Data port: Set the Data Port. The device will restart automatically after it's changed (Default: 3000; Optional: 0-65535).
- Web Port: Set the Web Port. The device will restart automatically after changed (Default: 80; Optional: 0-65535).
- Onvif Port: Set the Onvif Port. The device will restart automatically after changed (Default: 2000; Optional: 0-65535).
- Soap Port: Set the Soap Port (Default: 1936; Optional: 0-65535).
- RTMP Port: Set the RTMP Port (Default: 1935; Optional: 0-65535).
- RTSP Port: Set the RTSP Port. The device will restart automatically after changed (Default: 554; Optional: 0-65535).
- Visca Port: Set the Visca Port. The device will restart automatically after changed (Default: 1259; Optional: 0-65535).
- RTSP Obtaining method: rtp:// device IP address: 554 / live / av0 (av0 main stream; av1 secondary stream)
- RTMP Obtaining method: rtmp:// device IP address: 1935 / live / av0 (av0 main stream; av1 secondary stream)

2. Ethernet Parameters

- DHCP: Enable or disable the option to obtain IP automatically. By clicking on the "Save" button and rebooting the device, a display saying "Save successful" will be shown. (Default is set to ON).
- IP Address: You can set the IP Address. By clicking on the "Save" button and rebooting the device, a display saying "Save successful" will be shown. (Default is now set to 192.168.5.163).

Note: This IP address is the same with the one used to login to the web page..

- Subnet Mask: You can set the Subnet Mask (Default is set to 255.255.5.0).
- Default Gateway: You can set the Default Gateway (Default is set to 0.0.0.0).
- Physical Address: You can set the Physical Address (The parameter is read-only and can not be modified).
- By clicking on the "Save" button, the configuration will be validated when you see the display message: "Save successful"

3. DNS Parameters

- Preferred DNS Server: You can set the preferred DNS server (Default is set to 0.0.0.0).
- Alternate DNS Server: Alternate DNS server settings (Default is set to 0.0.0.0).
- By clicking on the "Save" button, the configuration will be validated when you see the display message: "Save successful".

4. NDI

- Switch: Set NDI function on or off.
NDI Name: User can change the NDI Name
NDI Group: User can change the NDI Group
- By clicking on the "Save" button, the configuration will be validated when you see the display message: "Save successful".

4.2.7 System Configuration

1. Device Properties

- Device Name: Set the device name (Default is Camera1. User can create their own).
- Device ID: Set the device ID (default is set to 1. Read-Only).
- System Language: Set the system language (Default: English; Optional: Simplified Chinese). Re-login after modification and save the setting.
- By clicking on the "Save" button, the configuration will be validated when you see the display message: "Save successful".

2. System Time

- Date Format: Set the Date Format (YYYY-MM-DD).
- Date Separator: (Default: "/" Optional: "." and "-").
- Time Zone: Set the Time Zone.
- Time Type: (Default: 24 hours; Optional: 12 hours).
- Time Setting: Set the Time Mode (to choose the computer time synchronization, NTP server time synchronization, or set manually).
- Computer Time: Set the time by synchronizing with your computer time.
- Update Interval: Set the NTP server to automatically update the time interval. Valid after setting NTP server synchronization (Default: One Day; Optional: 2-10 days).
- NTP Server Address or Domain Name: Set the NTP server address or domain name (default time.nits.gov). Valid after setting NTP server synchronization.
- NTP Server Port: Set the NTP server port (Default: 123). Valid after setting NTP server synchronization. - Set the time manually. Effective when set manually.
- By clicking on the "Save" button, the configuration will be validated when you see the display message: "Save successful".

3. User Management

- Select Users: You can set the User Type (the default is set to Administrator. Common User 1, Common User 2 are optional)
- User name: You can set the User Name (Select User Administrator default admin; select a common user1 default user1; to select a common user 2 default user2; user can modify their own)
- Password: You can set a Password (Select User Administrator default admin; select a common user1 default user1; to select a common user 2 default user2; user can modify their own).
- Password Confirmation: Confirm the input passwords are identical.
- By clicking on the “Save” button, the configuration will be validated when you see the display message: “Save successful”.

Note: User name and Password are case-sensitive.

4. Version Upgrade

- MCU Version: Displays MCU Version Information
- Camera Version: Displays Camera Version Information
- AF Version: Displays AF Version Information
- Update: Click “Browse ...” installation, to select the upgrade file in the pop-up window. Once you’ve selected the file, click on the “Upgrade” button. The upgrade dialog will appear and the device will reboot automatically after the update is successful. Make sure the power and network remains connected during the upgrading process.

Note: If you need to restore factory defaults, choose one of the three options:

- A. Through web to restore the factory default configuration.
- B. Through the recovery menu.
- C. Remote control shortcut: * # 6.

5. Restore Factory Setting

- Click on “Restore Factory Defaults” button and choose “yes” or “no”, then the device will restart automatically and restore factory setting.

6. Reboot

- Click on the “Reboot” button and choose “yes” or “no”.
- The device will restart automatically.

4.2.8 Logout

Click “Logout.” When the pop-up “Confirmation” dialog appears, select “Yes” or “No”. Choose “Yes” to exit the current page and return to the user login interface again.

5. Serial Communication Control

The OTTICA 4K can be controlled through RS232/RS485 interface; RS232C serial parameter are as follows:

Baud rate: 2400/4800/9600/115200 bits / sec;

Start bit: 1; data bits: 8; Stop bit: 1; Parity: None

5.1 VISCA Protocol List

5.1.1 VISCA Protocol Return Command

ACK/Completion Message		
	Command Packet	Note
ACK	z0 41 FF	Returned when the command is accepted.
Completion	z0 51 FF	Returned when the command has been executed.

Error Messages		
	Command Packet	Note
Syntax Error	z0 60 02 FF	Returned when the command format is different or when a command with illegal command parameters is accepted
Command Not Executable	z0 61 41 FF	Returned when a command cannot be executed due to current conditions. For example, when commands controlling the focus manually are received during auto focus.

5.1.2 VISCA Protocol Control Command

Command	Function	Command Packet	Notes
AddressSet	Broadcast	88 30 0p FF	p: Address setting
IF_Clear	Broadcast	88 01 00 01 FF	I/F Clear
CommandCancel		8x 21 FF	
CAM_Power	On	8x 01 04 00 02 FF	Power ON/OFF
	Off	8x 01 04 00 03 FF	
CAM_Zoom	Stop	8x 01 04 07 00 FF	
	Tele(Standard)	8x 01 04 07 02 FF	
	Wide(Standard)	8x 01 04 07 03 FF	
	Tele(Variable)	8x 01 04 07 2p FF	p = 0(low) - F(high)
	Wide(Variable)	8x 01 04 07 3p FF	
	Direct	8x 01 04 47 0p 0q 0r 0s FF	pqrs: Zoom Position
CAM_Focus	Stop	8x 01 04 08 00 FF	
	Far(Standard)	8x 01 04 08 02 FF	
	Near(Standard)	8x 01 04 08 03 FF	
	Far(Variable)	8x 01 04 08 2p FF	p = 0(low) - F(high)
	Near (Variable)	8x 01 04 08 3p FF	
	Direct	8x 01 04 48 0p 0q 0r 0s FF	pqrs: Focus Position
	Auto Focus	8x 01 04 38 02 FF	
	One Push Mode	8x 01 04 38 04 FF	
	Manual Focus	8x 01 04 38 03 FF	
CAM_Zoom Focus	Direct	8x 01 04 47 0p 0q 0r 0s 0t 0u 0v 0w FF	pqrs: Zoom Position tuvw: Focus Position

Command	Function	Command Packet	Notes
CAM_WB	Auto	8x 01 04 35 00 FF	
	3000K	8x 01 04 35 01 FF	
	4000k	8x 01 04 35 02 FF	
	One Push Mode	8x 01 04 35 03 FF	
	5000k	8x 01 04 35 04 FF	
CAM-WB (continued)	Manual	8x 01 04 35 05 FF	
	6500k	8x 01 04 35 06 FF	
	3500K	8x 01 04 35 07 FF	
	4500K	8x 01 04 35 08 FF	
	5500K	8x 01 04 35 09 FF	
	6000K	8x 01 04 35 0A FF	
	7000K	8x 01 04 35 0B FF	
CAM_RGain	Reset	8x 01 04 03 00 FF	Manual Control of R Gain
	Up	8x 01 04 03 02 FF	
	Down	8x 01 04 03 03 FF	
	Direct	8x 01 04 43 00 00 0p 0q FF	pq; R Gain
CAM_Bgain	Reset	8x 01 04 04 00 FF	Manual Control of B Gain
	Up	8x 01 04 04 02 FF	
	Down	8x 01 04 04 03 FF	
	Direct	8x 01 04 44 00 00 0p 0q FF	pq; B Gain
CAM_AE	Full Auto	8x 01 04 39 00 FF	Automatic Exposure mode
	Manual	8x 01 04 39 03 FF	Manual Control mode
	Shutter priority	8x 01 04 39 0A FF	Shutter Priority Automatic Exposure mode
	Iris Priority	8x 01 04 39 0B FF	Iris Priority Automatic Exposure mode
	Bright	8x 01 04 39 0D FF	Bright mode
CAM_Shutter	Reset	8x 01 04 0A 00 FF	Shutter Setting
	Up	8x 01 04 0A 02 FF	
	Down	8x 01 04 0A 03 FF	
	Direct	8x 01 04 4A 00 00 0p 0q FF	pq; Shutter Position

Command	Function	Command Packet	Notes
CAM_Iris	Reset	8x 01 04 0B 00 FF	Iris Setting
	Up	8x 01 04 0B 02 FF	
	Down	8x 01 04 0B 03 FF	
	Direct	8x 01 04 4B 00 00 0p 0q FF	pq: Iris Position
CAM_Gain Limit	Gain Limit	8x 01 04 2C 0p FF	p: Gain Positon
CAM_Bright	Reset	8x 01 04 0D 00 FF	Bright Setting
	Up	8x 01 04 0D 02 FF	
	Down	8x 01 04 0D 03 FF	
	Direct	8x 01 04 4D 00 00 0p 0q FF	pq: Bright Positon
CAM_ExpComp	On	8x 01 04 3E 02 FF	Exposure Compensation ON/OFF
	Off	8x 01 04 3E 03 FF	
	Reset	8x 01 04 0E 00 FF	Exposure Compensation Amount Setting
	Up	8x 01 04 0E 02 FF	
	Down	8x 01 04 0E 03 FF	
	Direct	8x 01 04 4E 00 00 0p 0q FF	pq: ExpComp Position
CAM_Back Light	On	8x 01 04 33 02 FF	Back Light Compensation
	Off	8x 01 04 33 03 FF	
CAM_WDRStrength	Reset	8x 01 04 21 00 FF	WDR Level Setting
	Up	8x 01 04 21 02 FF	
	Down	8x 01 04 21 03 FF	
	Direct	8x 01 04 51 00 00 00 0p FF	p: WDR Level Positon
CAM_NR (2D)		8x 01 04 53 0p FF	P=0-7 0:OFF
CAM_NR (3D)		8x 01 04 54 0p FF	P=0-8 0:OFF
CAM_Gamma		8x 01 04 5B 0p FF	p = 0 – 4 0: Default 1: 0.45 2: 0.50 3: 0.55 4: 0.63
CAM_Flicker	OFF	8x 01 04 23 00 FF	OFF
	50HZ	8x 01 04 23 01 FF	50HZ
	60HZ	8x 01 04 23 02 FF	60HZ

Command	Function	Command Packet	Notes
CAM_Aperture	Reset	8x 01 04 02 00 FF	Aperture Control
	Up	8x 01 04 02 02 FF	
	Down	8x 01 04 02 03 FF	
	Direct	8x 01 04 42 00 00 0p 0q FF	pq: Aperture Gain
CAM_Memory	Reset	8x 01 04 3F 00 pq FF	pq: Memory Number(=0 to 254) Corresponds to 0 to 9 on the Remote Commander
	Set	8x 01 04 3F 01 pq FF	
	Recall	8x 01 04 3F 02 pq FF	
CAM_LR_Reverse	On	8x 01 04 61 02 FF	Image Flip Horizontal ON/OFF
	Off	8x 01 04 61 03 FF	
CAM_PictureFlip	On	8x 01 04 66 02 FF	Image Flip Vertical ON/OFF
	Off	8x 01 04 66 03 FF	
CAM_ColorSaturation	Direct	8x 01 04 49 00 00 00 0p FF	P=0-14 0:60% 1:70% 2:80% 3:90% 4:100% 5:110% 6:120% 7:130% 8:140% 9:150% 10:160% 11:160% 12:180% 13:190% 14:200%
CAM_IDWrite		8x 01 04 22 0p 0q 0r 0s FF	pqrs: Camera ID (=0000 to FFFF)
SYS_Menu	ON	8x 01 04 06 06 02 FF	Turn on the menu screen
	OFF	8x 01 04 06 06 03 FF	Turn off the menu screen
IR_Receive	ON	8x 01 06 08 02 FF	IR (remote commander) receive On/Off
	OFF	8x 01 06 08 03 FF	
IR_ReceiveReturn	On	8x 01 7D 01 03 00 00 FF	IR(remote commander) receive message via the VISCA communication ON/ OFF
	Off	8x 01 7D 01 13 00 00 FF	
CAM_SettingvReset	Reset	8x 01 04 A0 10 FF	Reset Factory Setting
CAM_Brightness	Direct	8x 01 04 A1 00 00 0p 0q FF	pq: Brightness Position
CAM_Contrast	Direct	8x 01 04 A2 00 00 0p 0q FF	pq: Contrast Position

Command	Function	Command Packet	Notes
CAM_Flip	OFF	8x 01 04 A4 00 FF	Single Command For Video Flip
	Flip-H	8x 01 04 A4 01 FF	
	Flip-V	8x 01 04 A4 02 FF	
	Flip-HV	8x 01 04 A4 03 FF	
CAM_VideoSystem	Set camera video system	8x 01 06 35 00 0p FF	P: 0~E Video Format 0:1080P60 5:720P50 1:1080P50 6:1080P30 2:1080i60 7:1080P25 3:1080i50 8:720P30 4:720P60 9:720P25 A: 1080P59.94 B: 1080i59.94 C: 720P59.94 D: 1080P29.97 E: 720P29.97
Pan_tiltDrive	Up	8x 01 06 01 W WW 03 01 FF	VW: Pan speed 0x01 (low speed) to 0x18 (high speed) WW: Tilt speed 0x01 (low speed) to 0x14 (high speed) YYYY: Pan Position ZZZZ: Tilt Position
	Down	8x 01 06 01 W WW 03 02 FF	
	Left	8x 01 06 01 W WW 01 03 FF	
	Right	8x 01 06 01 W WW 02 03 FF	
	Upleft	8x 01 06 01 W WW 01 01 FF	
	Upright	8x 01 06 01 W WW 02 01 FF	
	DownLeft	8x 01 06 01 W WW 01 02 FF	
	DownRight	8x 01 06 01 W WW 02 02 FF	
	Stop	8x 01 06 01 W WW 03 03 FF	
	AbsolutePosition	8x 01 06 02 W WW 0Y 0Y 0Y 0Y 0Z 0Z 0Z 0Z FF	

Command	Function	Command Packet	Notes
Pan_tiltDrive (continued)	RelativePo- sition	8x 01 06 03 VV WW 0Y 0Y 0Y 0Y 0Z 0Z 0Z 0Z FF	VV: Pan speed 0x01 (low speed) to 0x18 (high speed) WW: Tilt speed 0x01 (low speed) to 0x14 (high speed) YYYY: Pan Position ZZZZ: Tilt Position
	Home	8x 01 06 04 FF	
	Reset	8x 01 06 05 FF	
Pan-tiltLimitSet	Set	8x 01 06 07 00 0W 0Y 0Y 0Y 0Y 0Z 0Z 0Z 0Z FF	W:1 UpRight 0:DownLeft YYYY: Pan Limit Posi- tion(TBD) ZZZZ: Tilt Limit Position(TBD)
	Clear	8x 01 06 07 01 0W 07 0F 0F 0F 07 0F 0F 0F FF	

5.1.3 Inquiry Command

Command	Function	Command Packet	Notes
CAM_PowerInq	8x 09 04 00 FF	y0 50 02 FF	On
		y0 50 03 FF	Off(Standby)
CAM_ZoomPosInq	8x 09 04 47 FF	y0 50 0p 0q 0r 0s FF	pqrs: Zoom Position
CAM_FocusAFModelInq	8x 09 04 38 FF	y0 50 02 FF	Auto Focus
		y0 50 03 FF	Manual Focus
		y0 50 04 FF	One Push Mode
CAM_FocusPosInq	8x 09 04 48 FF	y0 50 0p 0q 0r 0s FF	pqrs: Focus Position
CAM_WBModelInq	8x 09 04 35 FF	y0 50 00 FF	Auto
		y0 50 01 FF	3000K
		y0 50 02 FF	4000K
		y0 50 03 FF	One Push Mode
		y0 50 04 FF	5000K
		y0 50 05 FF	Manual
		y0 50 06 FF	6500K
		y0 50 07 FF	6500K
		y0 50 08 FF	3500K
		y0 50 09 FF	4500K
		y0 50 0A FF	5500K
		y0 50 0B FF	6000K
		y0 50 0B FF	7000K

Command	Function	Command Packet	Notes
CAM_RGainInq	8x 09 04 43 FF	y0 50 00 00 0p 0q FF	pq: R Gain
CAM_BGainInq	8x 09 04 44 FF	y0 50 00 00 0p 0q FF	pq: B Gain
CAM_AEModeInq	8x 09 04 39 FF	y0 50 00 FF	Full Auto
		y0 50 03 FF	Manual
		y0 50 0A FF	Shutter Priority
		y0 50 0B FF	Iris Priority
		y0 50 0D FF	Bright
CAM_ShutterPosInq	8x 09 04 4A FF	y0 50 00 00 0p 0q FF	pq: Shutter Position
CAM_IrisPosInq	8x 09 04 4B FF	y0 50 00 00 0p 0q FF	pq: Iris Position
CAM_Gain LimitInq	8x 09 04 2C FF	y0 50 0p FF	p: Gain Positon
CAM_BrightPosInq	8x 09 04 4D FF	y0 50 00 00 0p 0q FF	pq: Bright Position
CAM_ExpCompModeInq	8x 09 04 3E FF	y0 50 02 FF	On
		y0 50 03 FF	Off
CAM_ExpCompPosInq	8x 09 04 4E FF	y0 50 00 00 0p 0q FF	pq: ExpComp Position
CAM_BacklightModeInq	8x 09 04 33 FF	y0 50 02 FF	On
		y0 50 03 FF	Off
CAM_WDRStrengthInq	8x 09 04 51 FF	y0 50 00 00 00 0p FF	p: WDR Strength
CAM_NRLevel(2D) Inq	8x 09 04 53 FF	y0 50 0p FF	P: 2DNRLLevel
CAM_NRLevel(3D) Inq	8x 09 04 54 FF	y0 50 0p FF	P:3D NRLevel
CAM_FlickerModeInq	8x 09 04 55 FF	y0 50 0p FF	p: Flicker Settings(0: OFF,1: 50Hz,2:60Hz)
CAM_ApertureInq	8x 09 04 42 FF	y0 50 00 00 0p 0q FF	pq: Aperture Gain
CAM_PictureEffectModeInq	8x 09 04 63 FF	y0 50 00 FF	Off
		y0 50 04 FF	B&W
CAM_MemoryInq	8x 09 04 3F FF	y0 50 0p FF	p: Memory number last operated.
SYS_MenuModeInq	8x 09 06 06 FF	y0 50 02 FF	On
		y0 50 03 FF	Off
CAM_LR_ReverseInq	8x 09 04 61 FF	y0 50 02 FF	On
		y0 50 03 FF	Off

Command	Function	Command Packet	Notes
CAM_PictureFlipInq	8x 09 04 66 FF	y0 50 02 FF	On
		y0 50 03 FF	Off
CAM_ColorSaturationInq	8x 09 04 49 FF	y0 50 00 00 00 0p FF	p: Color Gain setting 0h (60%) to Eh (130%)
CAM_IDInq	8x 09 04 22 FF	y0 50 0p FF	p: Gamma ID
IR_ReceiveInq	8x 09 06 08 FF	y0 50 02 FF	On
		y0 50 03 FF	Off
IR_ReceiveReturn		y0 07 7D 01 04 00 FF	Power ON/OFF
		y0 07 7D 01 04 07 FF	Zoom tele/wide
		y0 07 7D 01 04 38 FF	AF ON/OFF
		y0 07 7D 01 04 33 FF	Camera _Backlight
		y0 07 7D 01 04 3F FF	Camera _Memery
		y0 07 7D 01 06 01 FF	Pan_titleDriver
CAM_BrightnessInq	8x 09 04 A1 FF	y0 50 00 00 0p 0q FF	pq: Brightness Position
CAM_ContrastInq	8x 09 04 A2 FF	y0 50 00 00 0p 0q FF	pq: Contrast Position
CAM_FlipInq	8x 09 04 A4 FF	y0 50 00 FF	Off
		y0 50 01 FF	Flip-H
		y0 50 02 FF	Flip-V
		y0 50 03 FF	Flip-HV
CAM_GammaInq	8x 09 04 5B FF	y0 50 0p FF	p: Gamma setting
CAM_VersionInq	8x 09 00 02 FF	y0 50 ab cd mn pq rs tu vw FF	ab cd: - vendor ID (0220) mn pq: - model ID ST (0950) U3 (3950) rs tu: - ARM Version vw: - Reserve

Command	Function	Command Packet	Notes
VideoSystemInq	8x 09 06 23 FF	y0 50 0p FF	P: 0~E Video format 0:1080P60 1:1080P50 2:1080i60 3:1080i50 4:720P60 5:720P50 6:1080P30 7:1080P25 8:720P30 9:720P25 A: 1080P59.94 B: 1080i59.94 C: 720P59.94 D: 1080P29.97 E: 720P29.97
Pan-tiltMaxSpeedInq	8x 09 06 11 FF	y0 50 ww zz FF	ww: Pan Max Speed zz: Tilt Max Speed
Pan-tiltPosInq	8x 09 06 12 FF	y0 50 0w 0w 0w 0w 0z 0z 0z 0z FF	www: Pan Position zzzz: Tilt Position

Note: [X] in the above table indicates the camera address to be operated, [y] = [x + 8].

5.2 Pelco-D Protocol Command List

Function	Byte1	Byte2	Byte3	Byte4	Byte5	Byte6	Byte7
Up	0xFF	Address	0x00	0x08	Pan Speed	Tilt Speed	SUM
Down	0xFF	Address	0x00	0x10	Pan Speed	Tilt Speed	SUM
Left	0xFF	Address	0x00	0x04	Pan Speed	Tilt Speed	SUM
Right	0xFF	Address	0x00	0x02	Pan Speed	Tilt Speed	SUM
Upleft	0xFF	Address	0x00	0x0C	Pan Speed	Tilt Speed	SUM
Upright	0xFF	Address	0x00	0x0A	Pan Speed	Tilt Speed	SUM
DownLeft	0xFF	Address	0x00	0x14	Pan Speed	Tilt Speed	SUM
DownRight	0xFF	Address	0x00	0x12	Pan Speed	Tilt Speed	SUM
Zoom In	0xFF	Address	0x00	0x20	0x00	0x00	SUM
Zoom Out	0xFF	Address	0x00	0x40	0x00	0x00	SUM
Focus Far	0xFF	Address	0x00	0x80	0x00	0x00	SUM
Focus Near	0xFF	Address	0x01	0x00	0x00	0x00	SUM

Function	Byte1	Byte2	Byte3	Byte4	Byte5	Byte6	Byte7
Set Preset	0xFF	Address	0x00	0x03	0x00	Preset ID	SUM
Clear Preset	0xFF	Address	0x00	0x05	0x00	Preset ID	SUM
Call Preset	0xFF	Address	0x00	0x07	0x00	Preset ID	SUM
Query Pan Position	0xFF	Address	0x00	0x51	0x00	0x00	SUM
Query Pan Position Response	0xFF	Address	0x00	0x59	Value High Byte	Value Low Byte	SUM
Query Tilt Position	0xFF	Address	0x00	0x53	0x00	0x00	SUM
Query Tilt Position Response	0xFF	Address	0x00	0x5B	Value High Byte	Value Low Byte	SUM
Query Zoom Position	0xFF	Address	0x00	0x55	0x00	0x00	SUM
Query Zoom Position Response	0xFF	Address	0x00	0x5D	Value High Byte	Value Low Byte	SUM

5.3 Pelco-P Protocol Command List

Function	Byte1	Byte2	Byte3	Byte4	Byte5	Byte6	Byte7	Byte8
Up	0xA0	Address	0x00	0x08	Pan Speed	Tilt Speed	0xAF	XOR
Down	0xA0	Address	0x00	0x10	Pan Speed	Tilt Speed	0xAF	XOR
Left	0xA0	Address	0x00	0x04	Pan Speed	Tilt Speed	0xAF	XOR
Right	0xA0	Address	0x00	0x02	Pan Speed	Tilt Speed	0xAF	XOR
Upleft	0xA0	Address	0x00	0x0C	Pan Speed	Tilt Speed	0xAF	XOR
Upright	0xA0	Address	0x00	0x0A	Pan Speed	Tilt Speed	0xAF	XOR
DownLeft	0xA0	Address	0x00	0x14	Pan Speed	Tilt Speed	0xAF	XOR
DownRight	0xA0	Address	0x00	0x12	Pan Speed	Tilt Speed	0xAF	XOR
Zoom In	0xA0	Address	0x00	0x20	0x00	0x00	0xAF	XOR
Zoom Out	0xA0	Address	0x00	0x40	0x00	0x00	0xAF	XOR
Focus Far	0xA0	Address	0x01	0x00	0x00	0x00	0xAF	XOR
Focus Near	0xA0	Address	0x02	0x00	0x00	0x00	0xAF	XOR

Function	Byte1	Byte2	Byte3	Byte4	Byte5	Byte6	Byte7	Byte8
Set Preset	0xA0	Address	0x00	0x03	0x00	Preset ID	0xAF	XOR
Clear Preset	0xA0	Address	0x00	0x05	0x00	Preset ID	0xAF	XOR
Call Preset	0xA0	Address	0x00	0x07	0x00	Preset ID	0xAF	XOR
Query Pan Position	0xA0	Address	0x00	0x51	0x00	0x00	0xAF	XOR
Query Pan Position Response	0xA0	Address	0x00	0x59	Value High Byte	Value Low Byte	0xAF	XOR
Query Tilt Position	0xA0	Address	0x00	0x53	0x00	0x00	0xAF	XOR
Query Tilt Position Response	0xA0	Address	0x00	0x5B	Value High Byte	Value Low Byte	0xAF	XOR
Query Zoom Position	0xA0	Address	0x00	0x55	0x00	0x00	0xAF	XOR
Query Zoom Position Response	0xA0	Address	0x00	0x5D	Value High Byte	Value Low Byte	0xAF	XOR

6. Camera Maintenance and Troubleshooting

6.1 Camera Maintenance

1. If the camera hasn't been used for long time, please turn off the power adapter switch and AC plug.
2. Use a soft cloth or tissue to clean the camera cover.
3. Use soft cloth to clean the lens. Do not use strong or corrosive cleanser and avoiding scuffing.

6.2 Troubleshooting

1. No Video Output

- A. Check whether the camera power supply is connected, that the voltage is normal, and that the power indicator is lit.
- B. Check to see if the camera performs the self-inspection after restarted.
- C. Check whether the bottom of the DIP switch is in the normal operating mode
- D. Check whether the video output cable or video display is normal.

2. Image Dithering When Zooming In or Out

- A. Check whether the camera installation position is solid.
- B. Whether there is a shaking machine or objects around the camera.

3. Remote Controller Not Working

- A. The remote control address could be set to 1 (if the has been set back to the factory defaults, the remote control addresses need to be set back to 1 also).
- B. Check if the batteries are low or if they are installed properly in the remote controller.
- C. Check if the camera working mode is the normal operating mode
- D. Check whether the menu is closed. Camera control through the remote controller is only available after exiting the menu. If video is being output from LAN, the menu will not be displayed. After the menu automatically exists 30 seconds later, it can be controlled by remote controller.

4. Serial Port Not Working

- A. Check if the camera serial device protocol, baud rate, and address are all consistent.
- B. Check if the control cable is connected properly.
- C. Check if the camera working mode is in the normal operating mode

5. Web Page Not Logging In

- A. Check if the camera outputs video normally by connecting directly to the screen or monitor.
- B. Check whether the network cable is connected properly. (Ethernet port flashes yellow light to indicate normal network cable connection).
- C. Check if your camera's IP address is consistent with the computer network segment.

OTT-CONTROLLER



OTTICA IP PTZ Camera Controller VISCA, ONVIF, PELCO



Precautions

1. What is the function of CAM NUM when adding a network device?

CAM NUM will be associated and bound with the currently entered IP and port information.

It will quickly switch to the CAM NUM bound device when adding a device with the “CAM” button.

2. How do I enter an IP address?

The camera controller doesn't have a “.” button, so please enter the IP address with four segments.

Take the IP address 192.168.0.1 for example. It will automatically jump to next segment when finished inputting a segment with three numbers, 192 and 168; but after inputting a segment with only one number, 0, you must move the joystick rightward to switch over to the next segment to continue inputting.

3. How do I clear while in input mode?

Move the joystick leftward to clear the input information.

4. The home page of each mode refers to the displayed page when the controller initialization is complete.

In IP VISCA and ONVIF Mode, if you see the prompts of “Visca!” and “Onvif!”, the IP address displayed on the screen is local IP address of the controller. While the prompts of “Visca:” and “Onvif:” are shown on the page, the IP address displayed on-screen belongs to the connected device.

Table of Contents

Precautions	2
1. Product Overview	4
1.1 Product Features	4
1.2 Wiring Diagram	4
1.3 Technical Specifications	5
2. Function Description	5
2.1 Button Description	5
2.2 Rocker Switch and Knob	7
2.3 Joystick Control	7
2.4 Terminal Description of Back Panel Interfaces	8
3. Local Settings (SETUP)	8
3.1 Basic Settings	8
3.2 VISCA & IP VISCA Mode Shared Setting	9
3.3 IP VISCA Mode Setting	9
3.4 VISCA Mode Setting	9
3.5 PELCO Mode Setting	9
3.6 ONVIF Mode Setting	10
4. Connection and Control	10
4.1 Connection and Control in ONVIF Mode	10
4.2 Connection and Control in IP VISCA Mode	11
4.3 Control in VISCA & PELCO Mode	11
5. Web Page Configuration	11
5.1 Home Page	11
5.2 LAN Settings	12
5.3 Upgrade	13
5.4 Restore Factory	13
5.5 Reboot	13
Support, Warranty, Copyright	14

1. Product Overview

1.1 Product Features

Two IP control modes: IP VISCA & ONVIF

Two analog control modes: RS422 & RS232

Three Control Protocols: VISCA, ONVIF and PELCO

1.2 Wiring Diagram

Both the Controller and PTZ camera must be connected to the same LAN. The IP addresses of both the PTZ Camera and Controller must operate within the same network segment.

For example:

192.168.1.123 is within the same segment as 192.168.1.111

192.168.1.123 is not within the same segment as 192.168.0.125

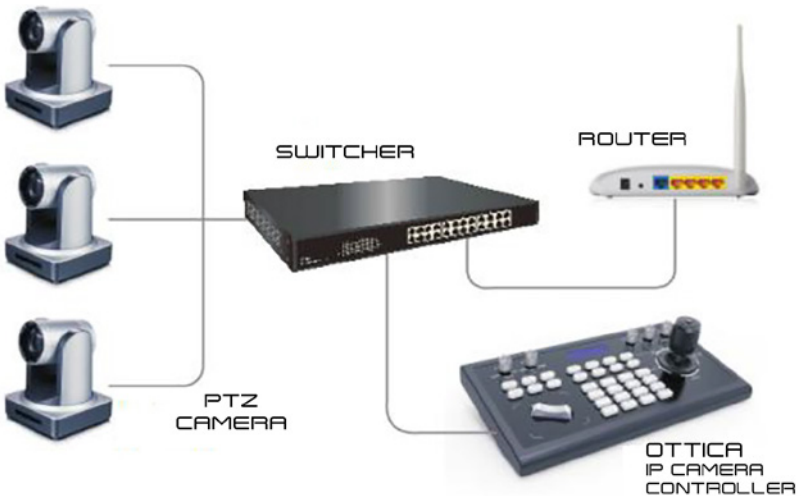

1.3 Technical Specifications

Ethernet	1 x Ethernet Port
Joystick	Four-dimensional joystick control (up, down, left, right) Rotatable for zooming Tele/Wide
Connection	Lead
Display	LCD
Prompt Tone	Button Sound Prompts On/Off
Power Supply	DC 12V1A±10%
Power Consumption	0.6 W Max
Operating Temperature	32°F-122°F
Storage Temperature	-4°F-158°F
Dimensions	320 x 180 x 100mm

2. Function Description

2.1 Buntton Description

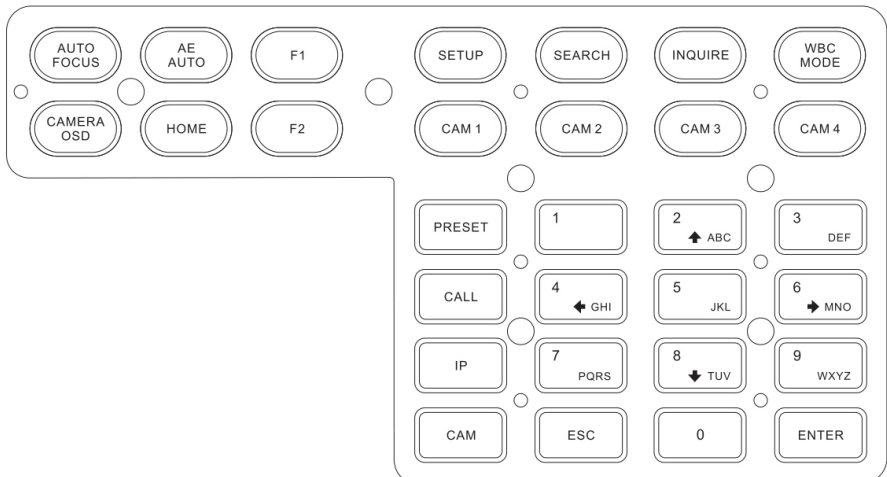

[AUTO FOCUS] Sets the camera in auto focus mode with this button. It will light up when the camera is in manual focus mode.

[AE AUTO] (Auto Aperture) Set the camera in automatic aperture mode with this button. It will light up when camera is in manual aperture mode.

[CAMERA OSD] Call/Close the camera OSD

[HOME] Returns the camera back to home position if camera OSD is off. When the camera OSD is on, the home button confirms the function of camera OSD.

[F1]~[F2] Custom function buttons. In VISCA and IP VISCA modes.

[SETUP] Local settings button, modifies & views local settings. Navigate menus using Joystick.

[SEARCH] Search for all available devices with ONVIF protocol in the LAN (only in ONVIF Mode).

[INQUIRE] Check added devices.

[WBC MODE] (Auto White Balance) Sets the camera in auto white balance mode. Button will light up when camera is in manual white balance mode.

[CAM1]~[CAM4] Quickly switch device button: Quickly switch to CAM NUM 1-4 devices (ONVIF, IP VISCA), or to address code 1-4 devices (VISCA, PELCO).

[PRESE] Short presses will enable you to set presets; long presses will enable you to delete presets. Use the number keys and the "ENTER" button, when setting or deleting presets.

[CALL] Use the number keys and "ENTER" button to move the camera to a preset.

[IP] Manually adds network devices (only in ONVIF and IP VISCA modes). Use the "ENTER" button to confirm each step of the setup.

[CAM] In IP VISCA and ONVIF modes, it will quickly switch to the CAM NUM bound device when adding a device via CAM.

In VISCA and PELCO modes, it will switch to the address code when entering a certain address. Use the "ENTER" button to confirm each step of the setup.

[1]~[9] Number keys of 0,1,2,3,4,5,6,7,8,9.

2,4,6,8 also serve as directional keys, which can control pan and tilt rotation, and camera OSD.

[ESC] Return

[ENTER] Confirm Button. Be sure to press this button to confirm any/all settings.

2.2 Rocker Switch and Knob

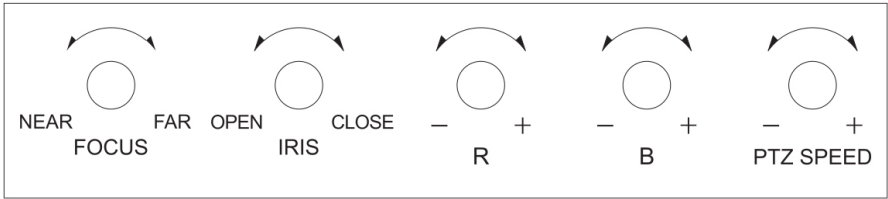

[NEAR] [FAR] Manually adjust the focal length.

[OPEN] [CLOSE] Manually adjust the aperture, OPEN(Aperture Plus)/CLOSE(Aperture minus)

[R-] [R+] Manually adjust the Red Gain

[B-] [B+] Manually adjust the Blue Gain

[PTZ SPEED-] [PTZ SPEED+] Adjust PTZ Speed 1-8: “-” = Slow. “+” = Fast.

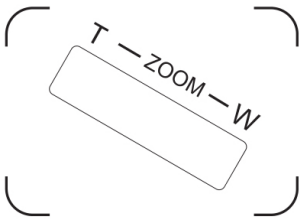

[T-ZOOM-W] Zoom Tele and Zoom Wide

2.3 Joystick Control

	Up		Down		Left
	Right		Zoom In		Zoom Out

2.4 Terminal Description of Back Panel Interfaces

Back Panel Details: RS422, RS232, DC-12V, Ethernet, Power Switch

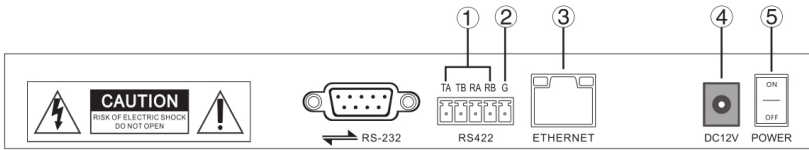

Number	Label	Physical Interface	Description
1	RS422	Control Output (TA, TB, TA, TB)	Connect to RS422 bus of the camera: TA to camera RA TB to camera RB RA to camera TA RB to camera TB
2	Ground	Control line ground (G)	Control signal Line ground
3	ETHERNET	Ethernet Port	Network Connection
4	DC-12V	Power Input	DV 12V Power Input
5	POWER	Power Switch	Power ON / OFF

3. Local Settings (SETUP)

3.1 Basic Settings

Move the joystick up and down to switch between basic settings. Move the joystick left or right to alter settings. Confirm settings with “ENTER” button.

1. Delete Device
2. Network Type: Dynamic and Static
3. Button Sound Prompt: On and Off
4. Language Setting: English and Chinese
5. Mode: VISCA, IP VISCA, ONVIF, PELCO
6. Local IP
7. Version Information
8. Restore Factory Settings
9. Function Button 1 (“F1”) Setup
10. Function Button 2 (“F2”) Setup

3.2 VISCA & IP VISCA Mode Shared Setting

1. F1: Custom function for F1 button (VISCA command)
2. F2: Custom function for F2 button (VISCA command)

Input custom name > ENTER > Input VISCA command

For example: If the command is 8101040702FF, then input 01040702 (0 can't be omitted)

3.3 IP VISCA Mode Setting

Delete the saved device:

Move the joystick up and down to view devices; Move the joystick rightward to view the device's port information; Move the joystick leftward to view the IP, CAM NUM information; ENTER to delete the selected device.

3.4 VISCA Mode Setting

Control Settings (set the baud rate for a certain address code):

Move the joystick up, down, left and right to switch addresses (1-7) > ENTER > Move the joystick left and right to switch baud rate > ENTER

EX: Select the address: 1 > ENTER > Select the baud rate: 9600 > ENTER

When the controller is switched to address 1, the control baud rate is 9600

3.5 PELCO Mode Setting

Control Settings (set the baud rate for a certain address code):

Move the joystick up, down, left and right to switch addresses (1-255) > ENTER > Move the joystick left and right to choose protocols > ENTER > Move the joystick left and right to switch baud rate > ENTER

EX: Select the address: 1 > ENTER > Select the protocol: PELCO-D > ENTER > Select the baud rate: 9600 > ENTER

When the controller is switched to address 1, the control baud rate is 9600, protocol is PELCO-D

3.6 ONVIF Mode Setting

Delete Saved Device:

Move the joystick up and down to view devices. Move the joystick rightward to view the device's port information. Move the joystick leftward to view the IP, CAM NUM information. Press "ENTER" to delete the selected device.

4. Connection and Control

4.1 Connection and Control in ONVIF Mode

Search and Add

In ONVIF mode, follow the steps below to add a LAN device to the PTZ controller:

1. After the controller has obtained IP address, simply press the SEARCH button.
2. All available devices with the ONVIF protocol in the LAN will be displayed on the controller when search process is complete.
3. Move the joystick up/down to select the device. Press the "ENTER" button to confirm.
4. It's required to enter the device's username, password and CAM NUM information when adding a device.
5. Press the "ENTER" button to save.
6. Alternatively, use the [IP] button to add a device manually.
7. Press the "INQUIRE" button to view the added device. Move the joystick up/down to view the saved device (move the joystick rightward to view the port). Press the "ENTER" button to select a camera to control, or use the CAM button to connect and control.

4.2 Connection and Control in IP VISCA Mode

The Searching function is not available in IP VISCA mode, but you can manually add a device.

1. Manually add device via the [IP] button.
2. Press the “INQUIRE” button to view the added device. Move the joystick up/down to view the saved device (move the joystick rightward to view the port); Press the “ENTER” button to select a camera to control, or use the CAM button to connect and control.

4.3 Control in VISCA & PELCO Mode

Simply set the address code and baud rate to control.
In PELCO Mode, correctly set the PELCO-D or PELCO-P protocol.

5. Web Page Configuration

5.1 Home Page

The Searching function is not available in IP VISCA mode, but you can manually add a device.

1. Connect the controller and computer to the same LAN and enter the controller’s IP address into the browser.
2. Default username: admin | Password: empty
3. Home page is as below:

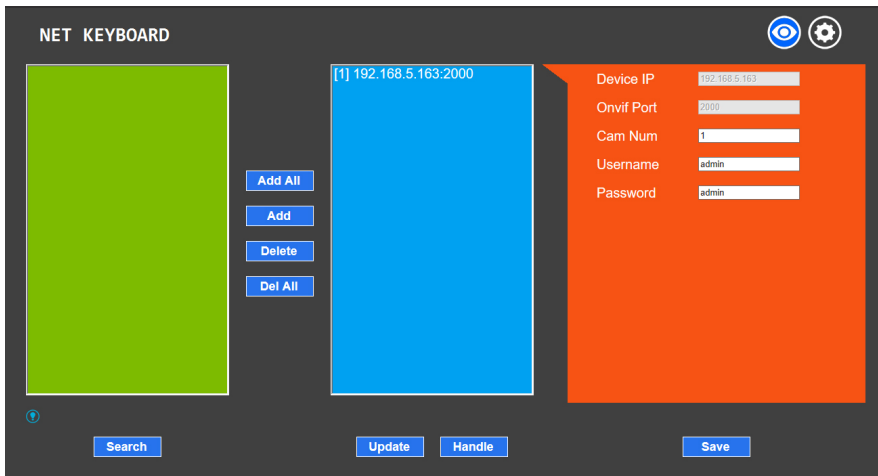

4. The home page consists of three segments: Search Device List (green); Added Device List (blue) or Manually Add (yellow); Device Details (orange).
5. Click the “Search” button to find ONVIF devices in the LAN. Devices will be displayed in the green frame automatically.
6. Select the device in the “Search Device List”, and click “Add” to complete. Press “Ctrl” for multiple selections.
7. Select the device in the “Added Device List”, and click “Delete” to complete. Press “Ctrl” for multiple selections.
8. After successfully adding a device, click the IP address in the “Added Device List” to edit the account and port information of the device.
9. After addition, deletion, and modification, click the “Save” button to confirm.

Note: Any modification to the configuration on home page needs to be saved by clicking the “Save” button; otherwise any modifications are invalid.

5.2 LAN Settings

To modify the device IP access way and port parameters in LAN Settings, refer to image below:

Click save to confirm.

NET KEYBOARD

LAN

Users

Upgrade

Restore Factory

Reboot

LAN				
Network Type	Static Address			
IP Address	192	168	5	210
Subnet Mask	255	255	255	0
Gateway	192	168	5	1
DNS Server	192	168	1	1

Save Update

Dynamic address (default access way): the Controller will automatically acquire IP address from the router.

Static address: Change the network to static address when necessary; simply input the network segment information to modify.

5.3 Upgrade

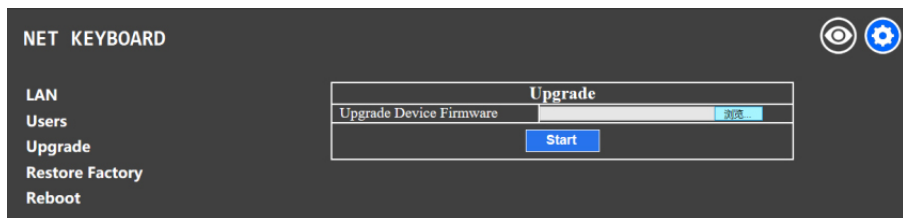

The upgrade function is available for maintenance and updates.

Choose the update file and click “start” to update the controller. It will auto reboot after updating.

Note: Do not operate the controller, shut the power off, or disconnect the device from the network during the upgrade process.

5.4 Restore Factory

Restore the controller to factory default settings when an unexpected failure occurs due to improper modifications. Please use factory restoration with caution.

5.5 Reboot

Click Reboot for maintenance if the controller has been running for a long period of time.

Learn More at www.ikancorp.com

Support

Contact email: support@ikancorp.com

CONDITIONS OF WARRANTY SERVICE

- Free service for one year from the day of purchase if the problem is caused by manufacturing errors.
- The components and maintenance service fee will be charged if the warranty period is expired.

Free service will not be provided in the Following Situations: (*Even if the product is still within the warranty period.)

- Damage caused by abuse or misuse, dismantling, or changes to the product not made by the company.
- Damage caused by natural disaster, abnormal voltage, and environmental factors, etc.

©2020 Ikan International. All rights reserved.