

LBX8-POE & LBX10-POE

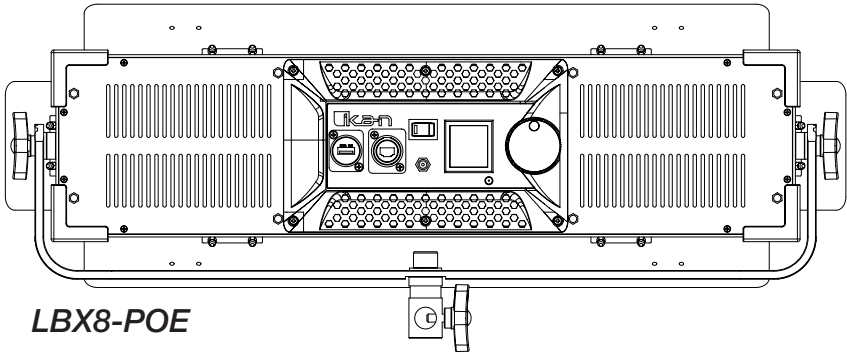

Ikan Lyra POE Light Series



LBX8-POE

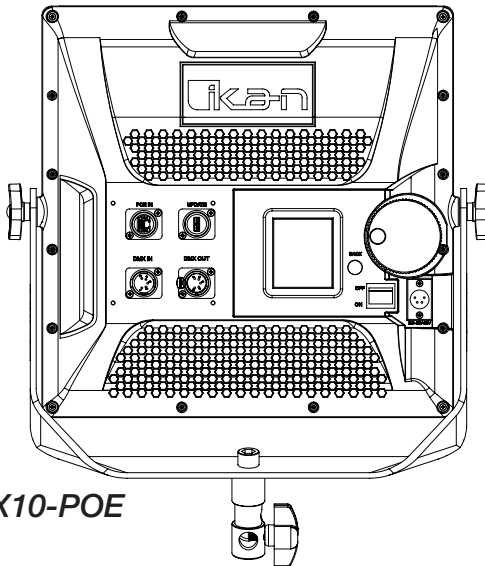

LBX10-POE

Table of Contents

1. Introduction	3
1.1 Overview	3
1.2 Key Features	3
1.3 Package Contents (What's Included)	3
2. Safety Information	3
2.1 General Safety Guidelines	3
2.2 Electrical Safety	3
2.3 Maintenance and Cleaning	4
2.4 Environmental Considerations	4
2.5 Compatible Cables	4
3. Specifications	4
3.1 LBX8-POE Specifications	4
3.2 LBX10-POE Specifications	4
4. Getting Started	4
4.1 Unpacking	4
4.2 Mounting Options	4
4.3 Powering On and Off	5
4.4 Basic Controls	5
5. POE Information	5
5.1 Understanding Power over Ethernet (PoE)	5
5.2 802.3bt Type 4 Compatibility	5
5.3 Connecting to PoE Source	5
5.4 Troubleshooting PoE Issues	5
6. Operation	6
6.1 Intensity Control	7
6.2 Color Temperature Adjustment	7
6.3 DMX Address	7
6.4 Net State (Art-Net, sACN, IP Address)	8
6.5 Firmware Updates	8
6.6 Web Interface	8
7. Maintenance	9
7.1 Cleaning and Care	9
7.2 Storage Guidelines	9
8. Troubleshooting	9
8.1 Power Issues	9
8.2 Light Output Issues	9
9. Warranty and Support	10
9.1 Limited Warranty	10
9.2 Contact Information	10

1. Introduction

1.1 Overview

The Ikan LYRA POE are lighting solutions designed to be effortlessly installed in studios with limited ceiling clearance. PoE++ lights are easy to install as they can be quickly and easily connected using an Ethernet cable. Equipped with high CRI LED chips and a soft panel, it emits a gentle, wraparound light that offers a clean and sharp shadow. With a color temperature range of 3200K to 5600K, it is highly versatile and ideal for any lighting production. The 100-degree beam angle offers ample coverage and the sturdy yoke, with its tension knobs, allows for easy adjustments and secure placement at any angle.

1.2 Key Features

- PoE++ (802.3bt Type 4) Compatibility
- LBX8-POE: 50W Power Output / Consumption
- LBX10-POE: 85W Power Output / Consumption
- Color Temperature Adjustable
- Intensity Control
- Art-Net & sACN DMX over IP

1.3 Package Contents

- LBX8-POE or LBX10-POE LED Light Fixture
- Yoke (Installed)
- Barn Doors (Installed Non-removable)
- Combo Pin
- Safety Wire
- User Manual

2. Safety Information

2.1 General Safety Guidelines

- Read and follow all instructions in this manual.
- Keep the light away from moisture and extreme temperatures.
- Do not attempt to disassemble the light; there are no user-serviceable parts inside.
- Keep the light away from flammable materials during operation.

2.2 Electrical Safety

- **NOTE:** Check minimal cable specs in section 2.5.
- Ensure that the power source complies with local electrical standards.
- If the cable is damaged, replace it immediately.

2.3 Maintenance and Cleaning

- Disconnect the light from the power source before cleaning.
- Use a soft, dry cloth for cleaning; do not use solvents or abrasive materials.

2.4 Environmental Considerations

- Dispose of the light and packaging in accordance with local regulations.
- Do not expose the light to rain or wet conditions.

2.5 Compatible Cables

- Use only Category 6 (Cat 6) or higher Ethernet cables.
- Choose cables with a minimum American Wire Gauge (AWG) of 24.
- Shielded cables are recommended to minimize electromagnetic interference.

3. Specifications

3.1 LBX8-POE Specifications

Power Output	50W
Color Temp Range	3200K to 5600K
Color Rendering Index (CRI)	>97

3.2 LBX10-POE Specifications

Power Output	85W
Color Temp Range	3200K to 5600K
Color Rendering Index (CRI)	>97

4. Getting Started

4.1 Unpacking

- Carefully unpack the light and its accessories. Ensure that all items listed in the Package Contents are present.

4.2 Mounting Options

- Use included combo pin to attach the light to a light stand or other mounting surfaces.

4.3 Powering On and Off

- Connect the Cat6 (24AWG or better) cable to the light and a compatible PoE++ power source.
- Flip the switch to the on position.
- The light will take up to 5 seconds to boot up. The readout screen flashing white is a normal indication that the light is turning on.

4.4 Basic Controls

- The yellow circular knob serves as both the enter button and a scroll wheel to adjust values. After adjusting to the values you want, confirm by pressing the back button and returning to previous options.

5. POE Information

5.1 Understanding Power over Ethernet (PoE)

- PoE allows for the simultaneous transmission of power and data over a single Ethernet cable, simplifying installation and reducing cable clutter.

5.2 802.3bt Type 4 Compatibility

- Ensure that the PoE source complies with the 802.3bt Type 4 standard to provide the necessary power for the LBX8-POE or LBX10-POE.

5.3 Connecting to PoE Source

- Connect a Cat6 or higher Ethernet cable to the light and a compatible PoE++ power source. Verify the connection is secure.

5.4 Troubleshooting PoE Issues

- If power issues arise, check the PoE source and cable for faults. Contact customer support if problems persist.

6. Operation

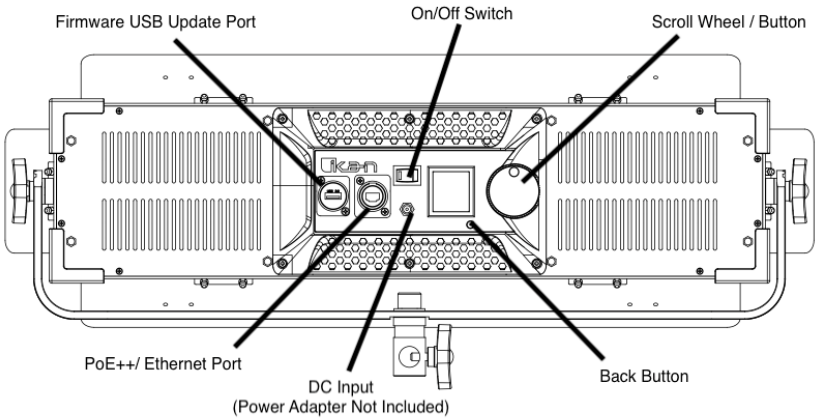
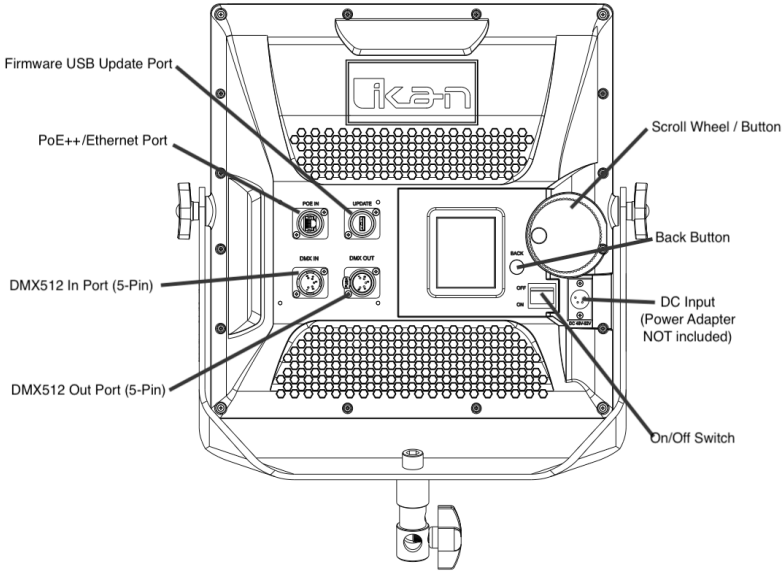

Intensity: 10%

CCT: 3200K

DMX Address: 01

Net State: ART-NET

IP: 192. 168. 000. 050

IP Mode: Static

Universe: 01

6.1 Intensity

- Adjust the brightness to achieve the desired illumination level. The light can be set from 0-100%, increasing and decreasing by increments of 1%.

6.2 CCT (Color Temperature)

- Adjust the color temperature between 3200K and 5600K.

6.3 DMX Address

- DMX512 channel selection from 1 to 511. Each light requires two channels for use.
- The first channel is intensity and the second is color temperature. DMX control has priority.
- When the light receives DMX signal a green dot will appear indicating that DMX signal is received.
- NOTE: Local control not available when DMX is connected.

6.4 Net State:

- Turns on the usage of DMX over IP protocols Art-Net or sACN. Once one of these are selected, select the following:

IP: IP address of the light. The light can be set as the following:

192.168.xxx.xxx

172.xxx.xxx.xxx

10.xxx.xxx.xxx

IP Mode: Set either DHCP or Static

Universe: Select the address for Art-Net or sACN

6.5 Firmware Updates

- Check the manufacturer's website for firmware updates to ensure optimal performance. Firmware updating instructions will be available with the firmware update files.

6.6 Web Interface

- The light fixture is equipped with a web-based Graphical User Interface (GUI) that facilitates the adjustment of DMX address, Art-Net settings, sACN settings, as well as Ethernet configurations including IP address, Net Mask, and Gateway preferences.
- Access the web interface by entering the IP address on the back of the light. For example, if the light shows 192.168.0.50 enter that into the web browser of a computer on the same network as the light fixture.

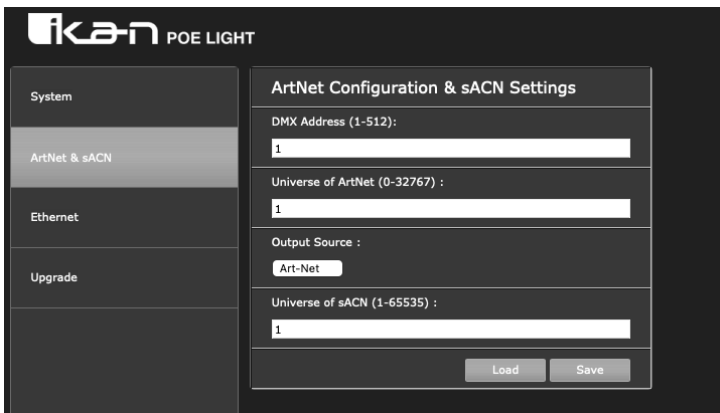

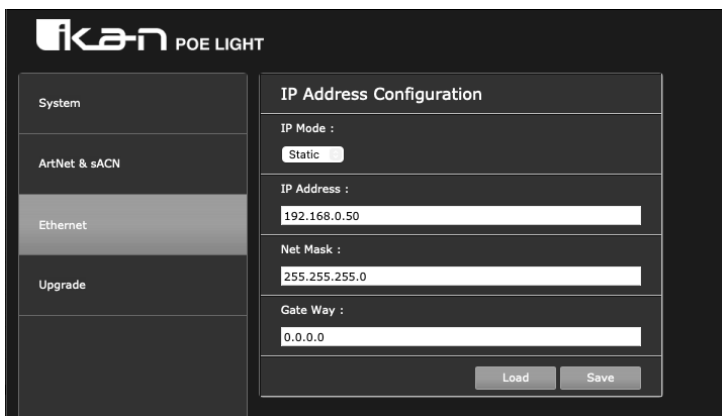

7. Maintenance

7.1 Cleaning and Care

- Clean the light with a soft, dry cloth. Avoid using solvents or abrasive materials.

7.2 Storage Guidelines

- Store the light in a dry, cool environment. Disconnect from power during extended periods of use.

8. Troubleshooting

8.1 Power Issues

- Check the PoE source, cable, and connections. Ensure proper compatibility with the 802.3bt Type 4 standard on PoE Switch.

8.2 DMX over IP Controls Not Working

- Check that the lights are in the correct universe in the controller and the light fixture.

8.2 FAQs

What are the advantages of PoE++ lights over the traditional versions?

- **Power Grid-Independent Installation:** PoE++ lights do not require new power outlets in the ceiling grid. This will save time and money required to create electrical drawing plans, apply for permits, and hire certified electricians to install the new outlets.

- **Simplified Power Management:** A single Ethernet cable will simultaneously power and DMX control the lights. This will simplify your installation and reduce clutter. Not only does this necessitate fewer cables, but when utilized in tandem with drop ceiling mounts, the discreet placement of Cat6 cables above the ceiling panels becomes possible. This contrasts with traditional AC-power cables, which must be installed below drop-ceiling tiles per code regulations. *Requires cables rated Cat6 24AWG Sheilded or better. Ikan's PoE++ lights include both Art-Net and sACN DMX-Over-IP protocols.*
- **Enhanced Flexibility:** PoE++ lights can be easily moved and repositioned without the constraints of traditional power outlets nor the need to manage the traditional DMX daisy chain.

What kind of PoE switch will I need?

- The lights require 802.3bt Type 4 switch with minimal 90W per port. Netgear's 90W AV PoE++ Switches have been fully tested and certified to be compatible with all Ikan PoE++ lights. They include the **IKM4250-10G2XF-PoE++** 8 port switch and the **IKM4250-26G4F-PoE++** 24 port switch.

	IKM4250-10G2XF-PoE++	IKM4250-26G4F-PoE++
PoE++ Ports (90W/port)	8	24
PoE++ Power Budget	720W	1440W
Non-PoE RJ45 Ports	2	2
SFP Ports	2	4
Power Consumption	With PoE: 837.7W	Single AC With PoE: 889W Dual AC With PoE: 1734W

How many lights can I put on each switch?

- The information below demonstrates the number of PoE++ lightings that can be supported by either the 8 port or 24 port Netgear PoE++ switches.

IKM4250-10G2XF-PoE++

- 8 x LBX10-POE (85W x 16 = 680W)
- 8 x LBX8-POE
- 8 x Any combination of LBX8-POE and LBX10-POE

IKM4250-26G4F-PoE++

- 16 x LBX10-POE (85W x 16 = 1360W)
- 24 x LBX8-POE
- If doing a combination of Lyra POE lights, calculate the total wattage of all lights to make sure the switch can support it.
 - For example, if using 10 x LBX10-POE and 10 x LBX8-POE
 - LBX10-POE 85W x 10 = 850W
 - LBX8-POE 50W x 10 = 500W
 - 850W + 500W = 1350W
 - 1350W is lower than the switch's max power budget of 1440W, and only uses 20 PoE++ ports, so this switch can support this configuration.

If I have both DMX512 5-pin and ArtNet or sACN RJ45 plugged in, which has control priority?

- DMX512 would have priority.

If both a power adapter and PoE++ are plugged in, will it damage the light?

- No, the light will automatically use the power adapter as that has priority over PoE++.
Power supply NOT included.

Learn More at www.ikancorp.com

Support

Contact email: support@ikancorp.com

CONDITIONS OF WARRANTY SERVICE

- Free service for 1 year from the day of purchase if the problem is caused by manufacturing errors.
- The components and maintenance service fee will be charged if the warranty period is expired.

Free service will not be provided in the Following Situations: (*Even if the product is still within the warranty period.)

- Damage caused by abuse or misuse, dismantling, or changes to the product not made by the company.
- Damage caused by natural disaster, abnormal voltage, and environmental factors, etc.

©2024 Ikan International. All rights reserved.