

# EVF50-KIT



5" 4K Support HDMI Electronic Viewfinder LCD Monitor Kit with Canon LP-E6 Battery Plate



## What's Included

- 1 x DH5e Monitor
- 1 x AC Adapter
- 1 x Canon E6 Battery Plate
- 1 x Monitor Cage with Viewfinder
- 1 x Screen Cleaning Wipe
- 1 x Screen Protection Film
- 1 x Sunhood
- 1 x Bluestar Eye Cushion



CHECKED BY



## Rear View

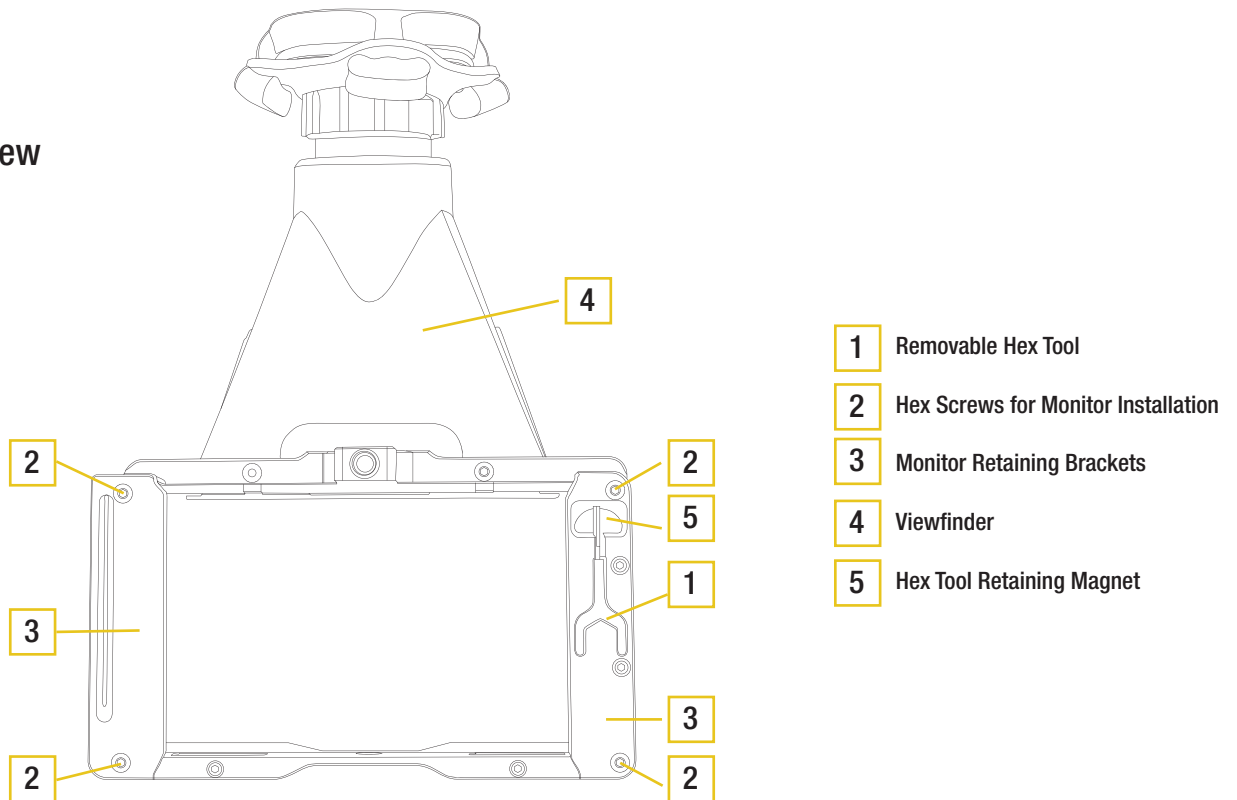

## Installation

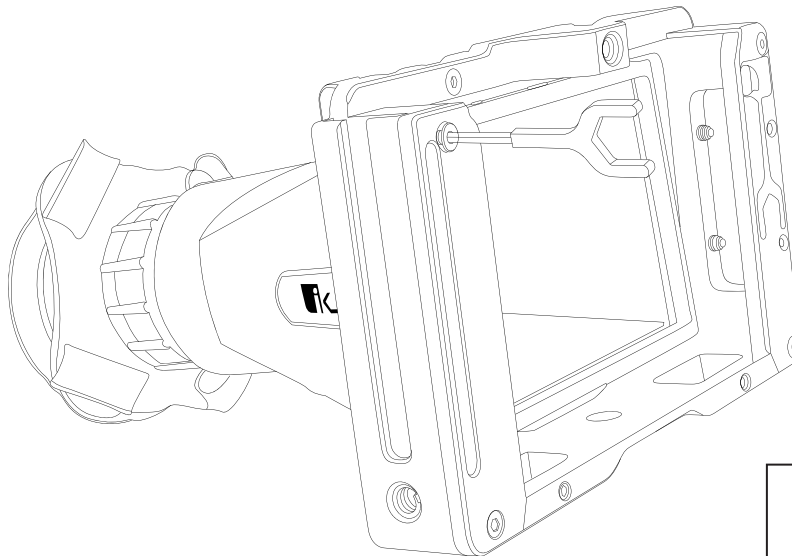

### NOTE:

You can also use the hex tool to tighten the cable lock screw.

1. Remove monitor retaining brackets with included hex tool
2. Slide in DH5e monitor from the rear
3. Re-install monitor retaining bracket

# Getting Started

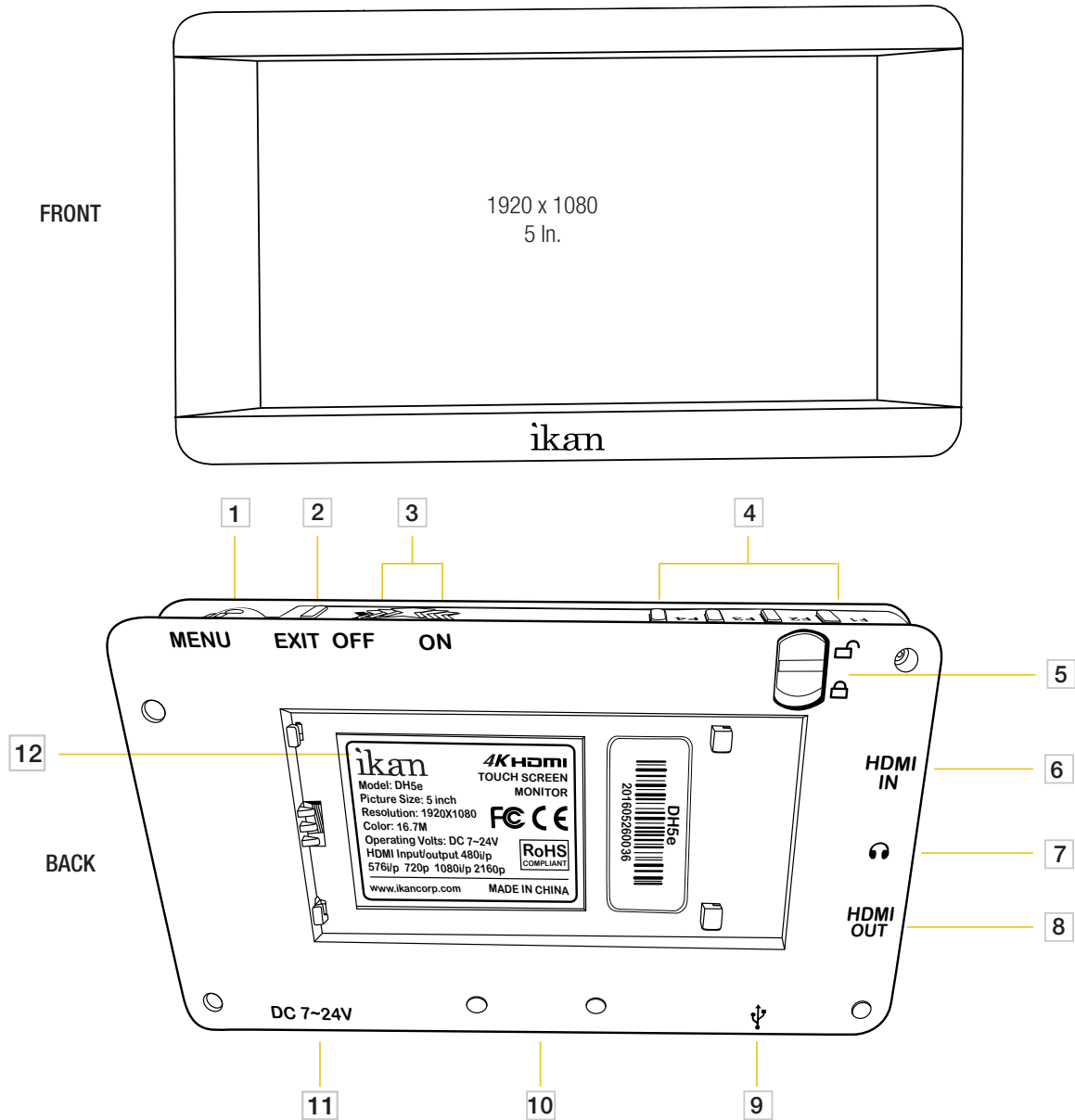

- |  |  |
|--|--|
| <p><b>1</b> <b>Menu Button - Scroll Wheel</b><br/>Used to enter and navigate the menu.</p> <p><b>2</b> <b>Exit / Aspect</b><br/>Used to exit the menu.</p> <p><b>3</b> <b>Power Button</b><br/>Power ON/OFF</p> <p><b>4</b> <b>Function Buttons</b><br/>Functions can be selected in the menu</p> <p><b>5</b> <b>Battery Plate Lock</b><br/>Locks Battery Plate</p> <p><b>6</b> <b>HDMI Input Terminal</b></p> | <p><b>7</b> <b>3.5mm Headphone Output</b></p> <p><b>8</b> <b>HDMI Output Terminal</b></p> <p><b>9</b> <b>USB Connector</b><br/>Used for Software Updates</p> <p><b>10</b> <b>1/4"-20 Threaded Insert</b></p> <p><b>11</b> <b>DC 7-24V Power Terminal</b><br/>Standard DC Connection</p> <p><b>12</b> <b>DV Battery Plate Slot</b><br/>Used for mounting DV Battery plate</p> |
|--|--|

# Touch Functions

- 1 Tap the screen to bring up the status display. From here you can check various settings. You can also see current menu settings. In addition, you can enable and disable features mapped to the function buttons.

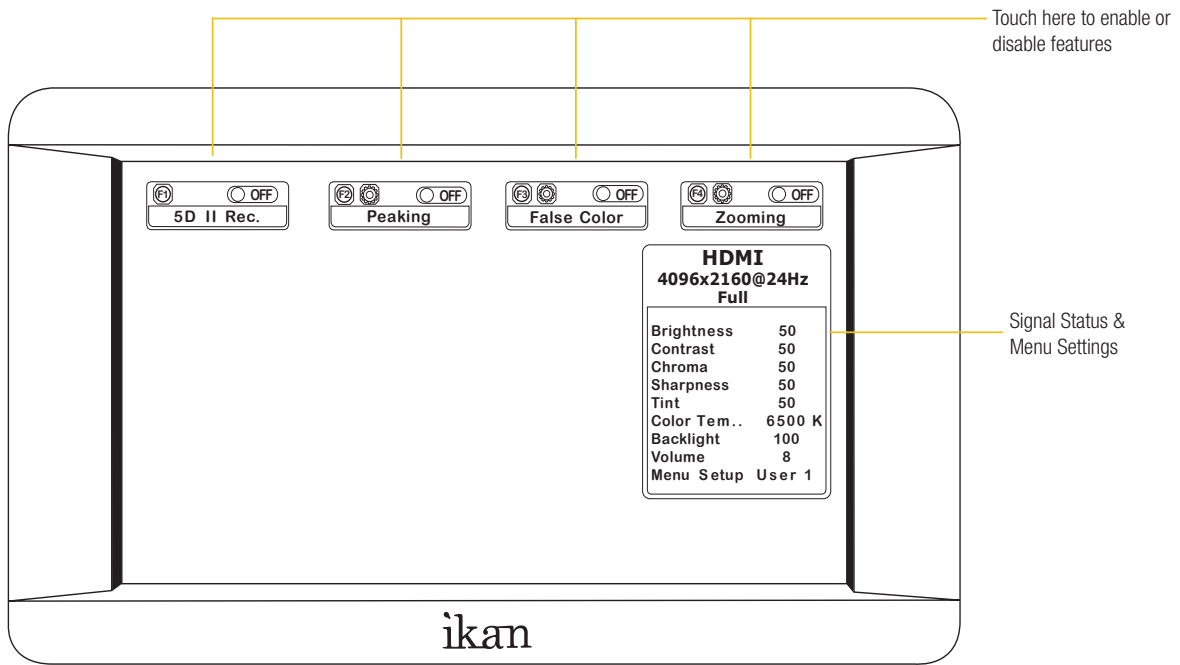

- 2 Pinch-to-Zoom allows you to zoom into your image by using your fingertips, similar to your smartphone!

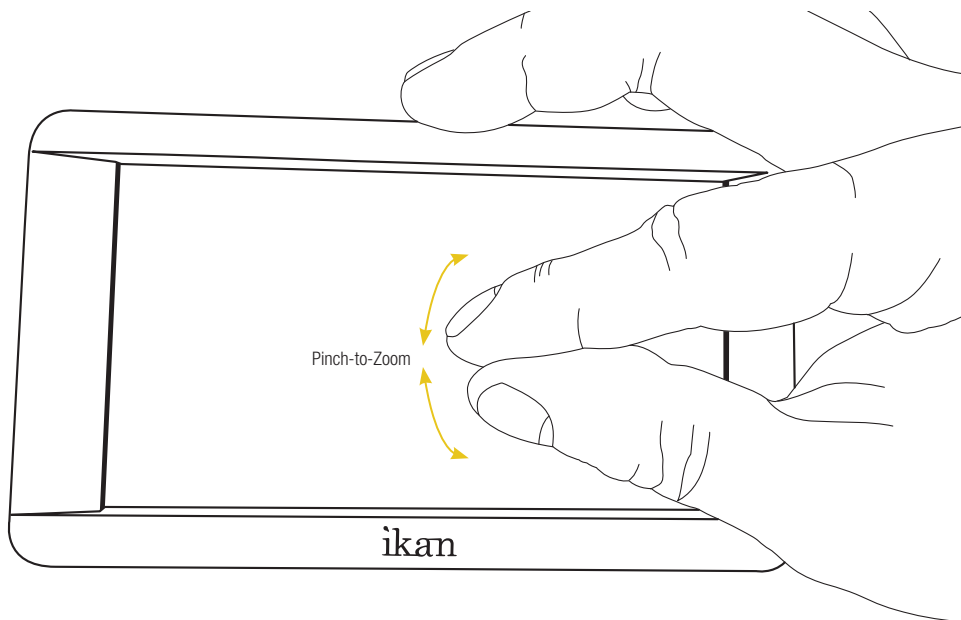

## Configuration of Setting Menus

Guide Masks	Toggle between the following: 80%, 90%, 15:9, 4:3, 1.5:1, 1.85:1, 2:1, 2.35:1, Custom
Crosshair	Activates Crosshair on center of screen.
Grids	Activates grid on the screen to assist with framing.
Video Config	Brightness: 0-100 Contrast: 0-100 Chroma: 0-100 Sharpness: 0-100 Tint: 0-100
Color Temperature	5600K, 6500K, 9300K, Manual
Backlight	Allows user to fine tune the intensity of the LCD Panel's backlight.
Aspect	Allows user to change the aspect ratio of the image.
System Config	OSD - Language: Choose between English & Chinese for OSD. OSD - Duration: Choose how long the menu stays active without activity. OSD - Transparency: Choose from low, medium, high, or off. MENU Setup - Allows 5 users to save menu settings. System Reset - Reset Settings to factory defaults.
Display Flip Mode	On/Off H Flip - Horizontal Flip On/Off V Flip - Vertical Flip On/Off OSD - Flip Mode - On/Off - Allows you to flip the On-Screen display to match the video. H Flip - Horizontal Flip On/Off V Flip - Vertical Flip On/Off
Touch Control	On/Off - Allows you to enable or disable the touch screen.

**Function Set Up on following page.**

# Function Set Up

## Function Set Up 1-4

Guides

Crosshair

Peaking

Underscan

DSLR Scaling

Zooming

EVF Mode

Pixel-to-Pixel

Check Field

HV Delay

Grids

False Color

Audio Wave

Clip Guides

Histogram

5DII Rec.

Firmware Version

Information

Update (USB)

Displays a crosshair on the center of the screen.

The DH5e is equipped with Monochrome Peaking features, which highlight the desired focus area in a bright, red outline. The operator adjusts the focus control until the red indicator outlines on the desired area are razor sharp, indicating optimal focus. For best results, be sure object is properly exposed.

The DSLR Scaling function will allow users to extend their DSLR camera's HDMI Video Output any option of four; Normal 3:2, 16:9, or Full Screen. Convenience Made simple.

This feature allows you to enlarge the image up to 3x.

Used with EVF Accessory. SOLD SEPARATELY.

The 1:1 pixel-to-pixel mapping allows you to emphasize on individual chosen elements in the shot. This feature is essential for ensuring that you are in focus.

Toggles between the Blue only, Red only, Green only, & Mono Modes. This is to help calibrate the image.

This function displays the blanking portion of the incoming signal.

Activates grid on screen to assist with framing.

This feature utilizes a full spectrum of assigned color indicators, ensuring flawless shot exposure. Under/Over luminance warnings enable the user to get the desired quality every time.

Displays Audio Stereo Levels.

The DH5e offers adjustable upper Clip Guide levels to accurately display overexposed images in any shooting condition. The operator simply assigns the upper IRE to their preference and any exposure over the set IRE limit will flash in a vivid purple, indicating only the over exposed area.

A graphical representation of the pixels exposed in your image. The left side of the graph represents the blacks or shadows, the right side represents the highlights or bright areas and the middle section is mid-tones. How high the peaks reach represent the number of pixels in that particular tone. This tool helps you get proper exposure.

Displays currently installed firmware.

Used to update firmware when a USB containing update file is inserted.

### NOTE:

To see further options for an active function, hold the function key for 2 seconds until option mode appears.



## Specifications

Aspect Ratio	16 x 9	Outputs	HDMI
Backlight	LED	Pixel Pitch	0.01925x0.05775 mm
Brightness	450 cd/m2	Power Consumption	6W
Build Material	Heavy Duty Plastic	Resolution	1920x1080
Color Depth	16.7 Millions	Response Time	20ms
Color System	PAL/NTSC/SECAM (Auto-Detected)	Screen Size	5 In.
Contrast Ratio	1000:1	Shipping Dimensions	3 x 14.75 x 7.75 In.
Dimensions	5.5 x 3.2 x 0.7 In.	Shipping Weight	2 lbs
Input Voltage	DC 7V - 24V	Viewing Angle	160° Horizontal / 160° Vertical
Inputs	HDMI	Weight	0.2 lbs
Operating Temperature	0°C~50° (32°F~122°F)		

## Supported Video Signals

HDMI	720x480i & 720x480p @ 59.94, 60 Hz
	720x576i @ 50 Hz
	1280x720p @ 23.97, 24, 25, 29.94, 30, 50, 59.94, 60 Hz
	1920x1080i @ 50, 59.94, 60 Hz
	1920x1080psf @ 24, 25, 29.97, 30 Hz
	1920x1080p @ 23.97, 24, 25, 29.94, 30, 50, 59.94, 60 Hz
	3840x2160p @ 24, 25, 30 Hz
	4096x2160p @ 24 Hz

## Optional Accessories

### MOUNTS

<b>MA207</b>	7 In. Articulating Arm
<b>MA211</b>	11 In. Articulating Arm
<b>MA211-R</b>	11 In. Articulating Arm w/ Single Rod Mount

### BATTERY PLATES

<b>BP5-C</b>	Canon 900 Battery Plate
<b>BP5-E6</b>	Canon LP-E6+ Battery Plate
<b>BP5-P</b>	Panasonic D54 Battery
<b>BP5-S</b>	Sony L Series Battery Plate
<b>BP5-N</b>	Nikon EN-EL15 Battery Plate
<b>BP5-PG6</b>	Panasonic G6 Battery Plate
<b>BP5-SU</b>	Sony BP-U Series Battery Plate

## Learn More

More dynamic information at official website: [www.ikancorp.com](http://www.ikancorp.com)

## Support

Contact email: [support@ikancorp.com](mailto:support@ikancorp.com)

---

### CONDITIONS OF WARRANTY SERVICE

- Free service for one year from the day of purchase if the problem is caused by manufacturing errors.
- The components and maintenance service fee will be charged if the warranty period is expired.

#### **Free Service will not be Provided in the Following Situations:(\*Even if the product is still within the warranty period.)**

- Damage caused by abuse or misuse, dismantling, or changes to the product not made by the company.
- Damage caused by natural disaster, abnormal voltage, and environmental factors, etc.

©2018 ikan Corporation. All rights reserved

