

COMICA

PROFESSIONAL AUDIO EQUIPMENT

CVM-V30 PRO

Directional Condenser Shotgun Video Microphone



USER MANUAL

Foreword

Thanks for purchasing COMICA CVM-V30 PRO Cardioid Directional Microphone, the item is specially designed for professional DSLR, Camcorder to work for review, meeting, video, etc. It comes with very sensitive directing and built-in electric circuit design, which takes you extra multi-functions like 'Adjusted sensitivity', 'Low-cut Filter', etc, and make your audio with good-quality.

Main Features

- . Super Cardioid Polar Pattern
- . Low-cut Filter
- . 10dB Adjustable Sensitivity
- . Low Self-noise
- . Super Anti-interference
- . Special Design for Excellent Shock-absorbing
- . Packed with Wind-Screen and Wind-Muff
- . Cold-shoe Design with 1/4 Thread at Bottom



Super Cardioid



Excellent Shock-absorbing



10dB Adjustable Sensitivity



Super Anti-Interference



Low-cut Filter



Wind Muff



Low Self-noise



Easy to install

Notice

- ⚠ Please carefully read this user manual before using
- ⚠ The LED Indicator light will keep on with green color to help you check if the item or power normally work
- ⚠ The product is belong to the super accurate instrument, please pay attention to avoid any dropping, collision or thump
- ⚠ Please do not put the device beside the heat or interference source, like radiator, Roaster or air-condition etc
- ⚠ Please keep this product in the dry environment
- ⚠ Do not expose this device in rain or moist environment

Package Contents

- ① Mic Body (Including Windscreen)
- ② Wind Muff
- ③ User Manual
- ④ Warranty Card

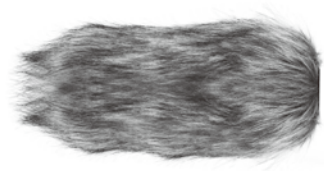

Components and Instruction

Mic Body

- ① Mic Body and Windscreen
- ② AAA Battery Holder
- ③ Low-cut Filter Button
- ④ Power/Sensitivity Button
- ⑤ Working Indication
- ⑥ Fixing Screw
- ⑦ 1/4 Cold-shoe Mount
- ⑧ Shock Mount
- ⑨ 3.5mm Audio Output Cable

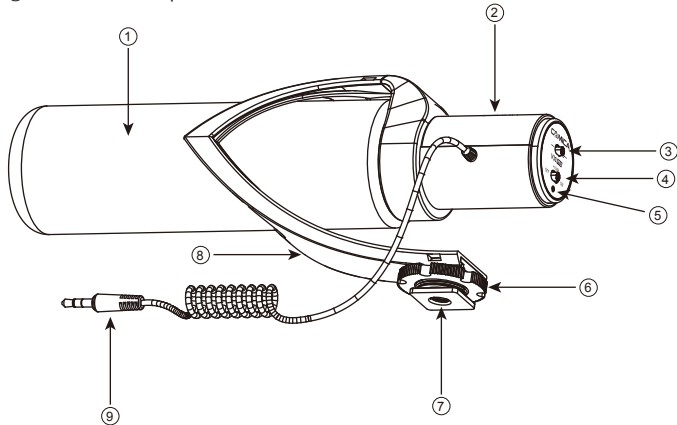

Installation and Usage

1. Installation

1.1 Put Batteries into Microphone

1.11 Refer to the illustration, Press down the battery door and follow the arrow to push outward, then the battery door is opened

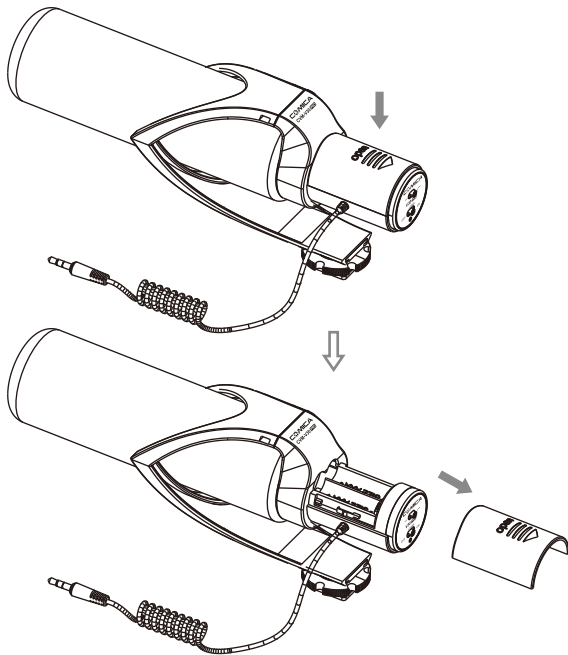

1.12 Put into the batteries, and then push forward to close the battery door

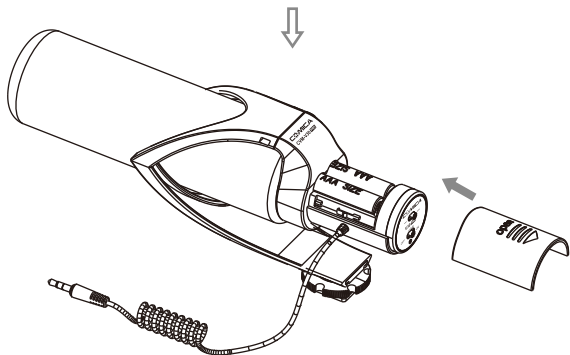
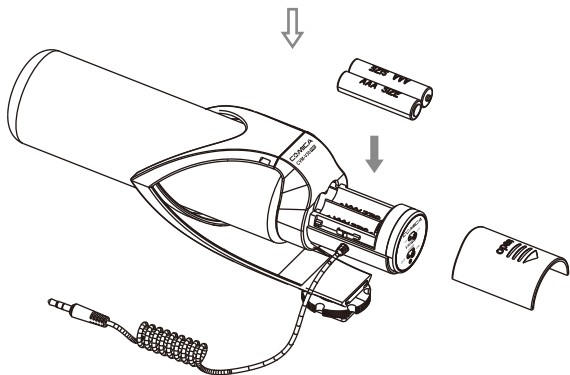

1.2 Install the Wind-Muff to Microphone

1.21 Open the Wind Muff from the "INSERT HERE"

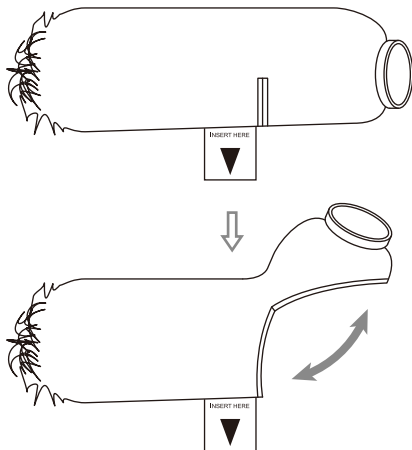

1.22 Insert the mic into the Wind Muff

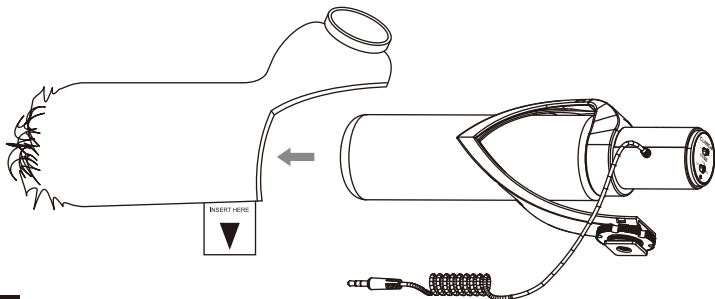

1.23 Stretch the end of the wind Muff

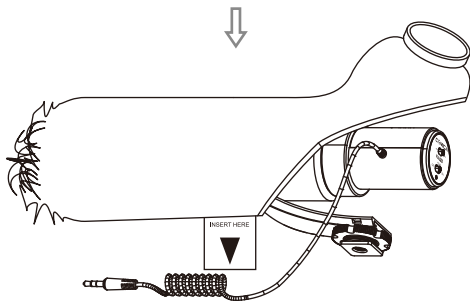
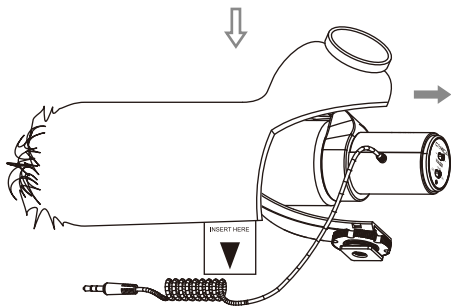

1.24 Wrap the end of the mic with the end of Wind Muff

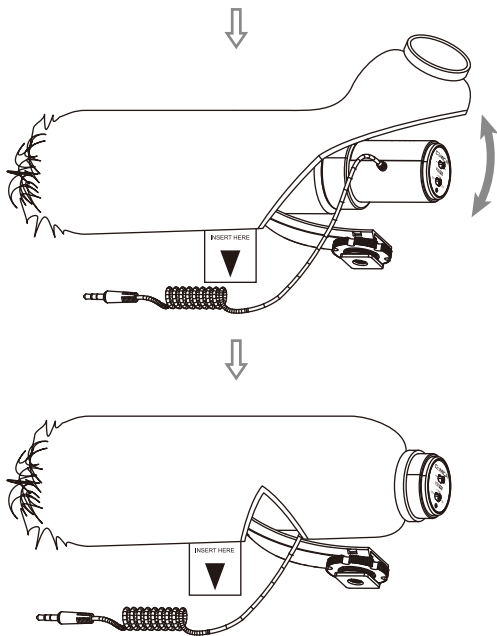

1.3 Install the Mic onto Camera

1.31 Connect the Mic onto the Camera via cold-shoe, then fasten the fixing screw

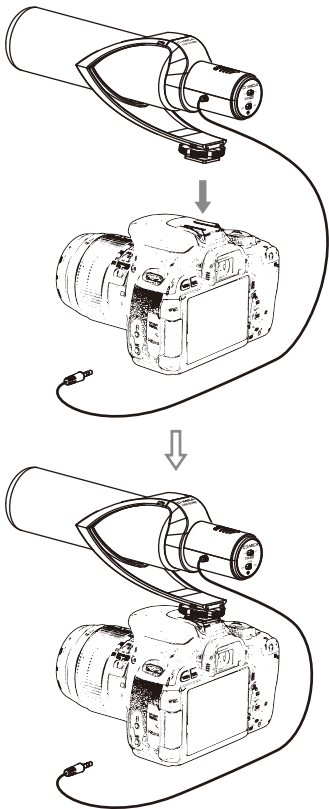

1.32 Connect the 3.5mm audio cable of Mic into the Camera

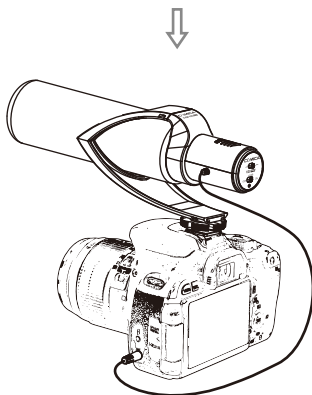
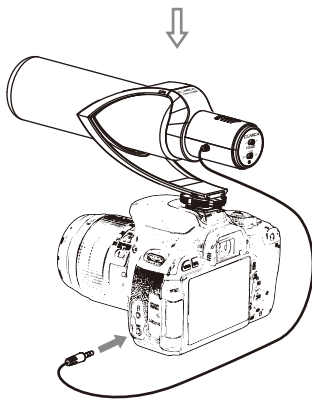

2. Operation

2.1 Low-cut Filter function

Refer to the illustration, switch the low-cut filter function button to right position, then the function works

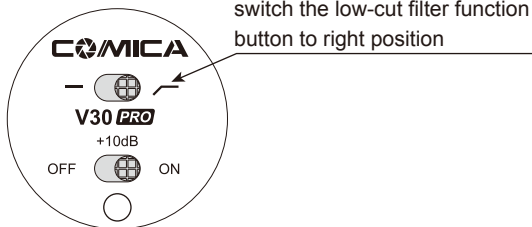

Low-cut Filter Note:

Filter background frequencies lower than 80Hz, such as unwanted noise produced by wind, focusing, traffic, etc.

👉 Recording maybe be adversely affected by using the low-cut filter, so only use as needed

2.2 Indication Lamp Status

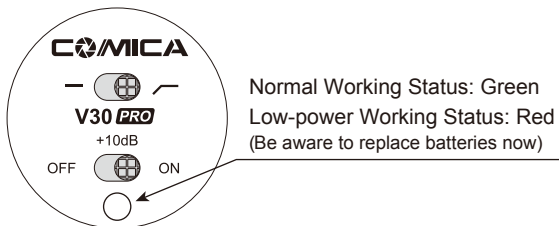

2.3 Power/+10 dB Sensitivity Adjusting Function

2.31 Switch the button to 'on' position, then the mic go into the normal voice picking-up status

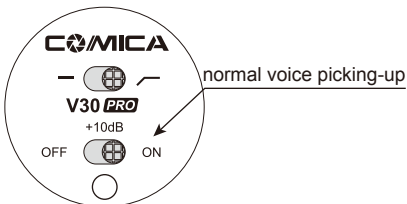

2.32 Switch the button to '+10 dB' position, then the sensitivity can be increased with 10 dB, The recording sound will be increased accordingly

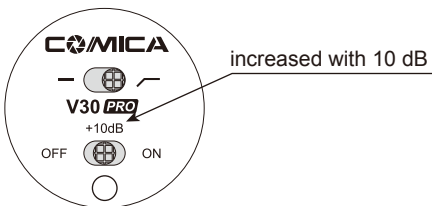

2.33 Switch the button to 'off' position, then the mic is powered off

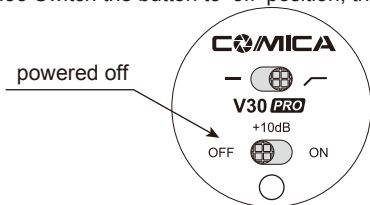

Specification

Specification:

Polar Pattern	Super Cardioid
Frequency Range	40Hz~20,000Hz
Sensitivity	-33dB±2dB/-23dB±2dB
Output Impedance	200 Ω
Dynamic Range	100dB
Max. SPL	114dB
Signal to Noise Ratio	78dB
Audio Output	3.5mm
Battery	AAA 1.5V x 2
Battery Life	200h
Weight	114g
Dimension	210 x 62 x 80mm

Frequency Response:

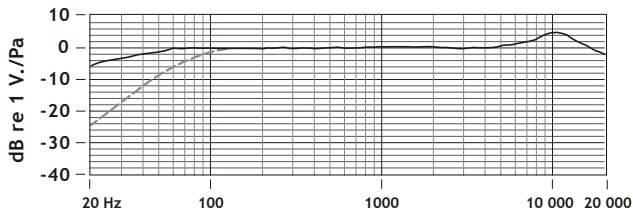

Polar Pattern :

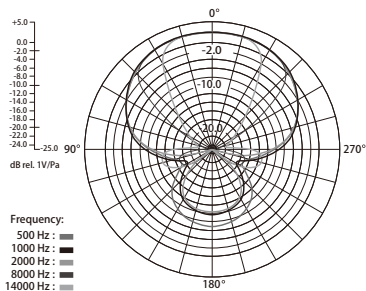



www.comica-audio.com