

# VL35

## QUICKSTART GUIDE

3.5" 4K HDMI Field Monitor w/ Canon LP-E6 Battery Plate



### What's Included

- 1 x VL35 Monitor
- 1 x AC Adapter
- 1 x Camera Shoe Mount
- 1 x Canon E6 Battery Plate
- 1 x AV Break Out Cable
- 1 x Screen Cleaning Wipe

ikan

[www.ikancorp.com](http://www.ikancorp.com)

[support@ikancorp.com](mailto:support@ikancorp.com)

713.272.8822

© 2016 ikan Corporation. All rights Reserved

# Getting Started

Front

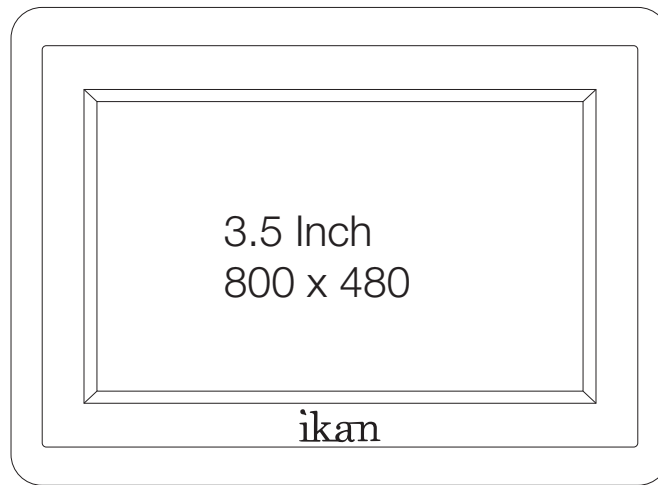

Back

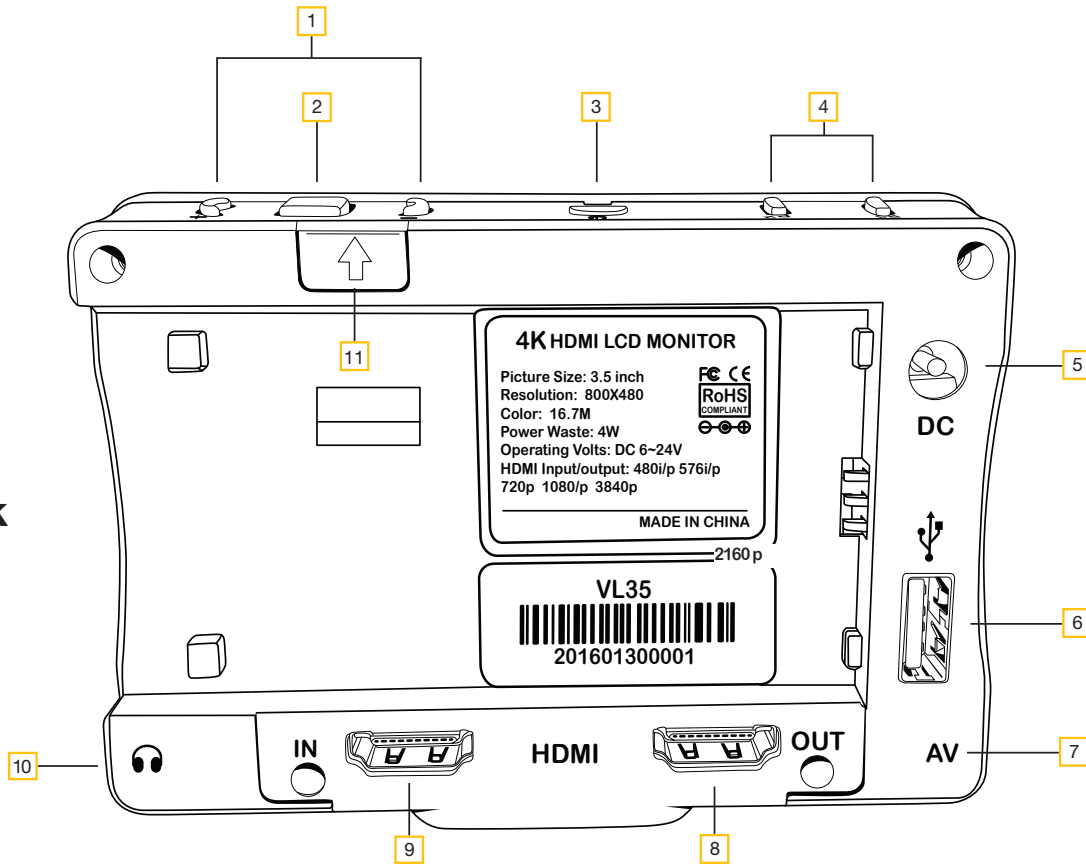

**1** Menu Navigation Buttons

**2** Menu Button  
Used to enter menu and make selections

**3** Power Button  
Power ON/OFF

**4** Function Buttons

**5** DC Power Terminal  
6-24V DC Connection

**6** USB Connector  
Used for Software Updates

**7** 3.5mm Video Input  
Use Included Breakout cable for composite video input

**8** HDMI Output Terminal

**9** HDMI Input Terminal

**10** 3.5mm Headphone Output

**11** Battery Plate Release  
Push down to lock the battery plate  
Push up to unlock the battery plate

# Configuration of Setting Menus

- Input Source** ————— Toggle between HDMI and Composite Video Inputs
- Guides** ————— Toggle between the following:  
80%, 90%, 15:9, 4:3, 1.5:1, 1.85:1, 2:1, 2.35:1
- Crosshair** ————— Activates Crosshair on center of screen
- Grids** ————— Activates grid on the screen to assist with framing
- Video Config** —————  
Brightness: 0-100  
Contrast: 0-100  
Chroma: 0-100  
Sharpness: 0-100  
Tint: 0-100
- Color Temp** ————— 5600K, 6500K, 9300K, Manual
- Backlight** ————— Allows user to fine tune the intensity of the LCD Panel's backlight
- Aspect** ————— Allows user to change the aspect ratio of the image
- System Config** —————  
OSD - Language: Choose between English & Chinese for OSD  
OSD - Duration: Choose how long the menu stays active without activity  
OSD - Transparency: Adjust the transparency of the on-screen menu  
System Reset - Reset Settings to Factory Defaults
- Menu Setup** ————— This function recalls user-defined value settings. The user settings will remain in memory indefinitely and can be erased by using the reset option in the main menu.
- Power Mode** ————— This option allows you to choose how the monitor behaves when power is applied.

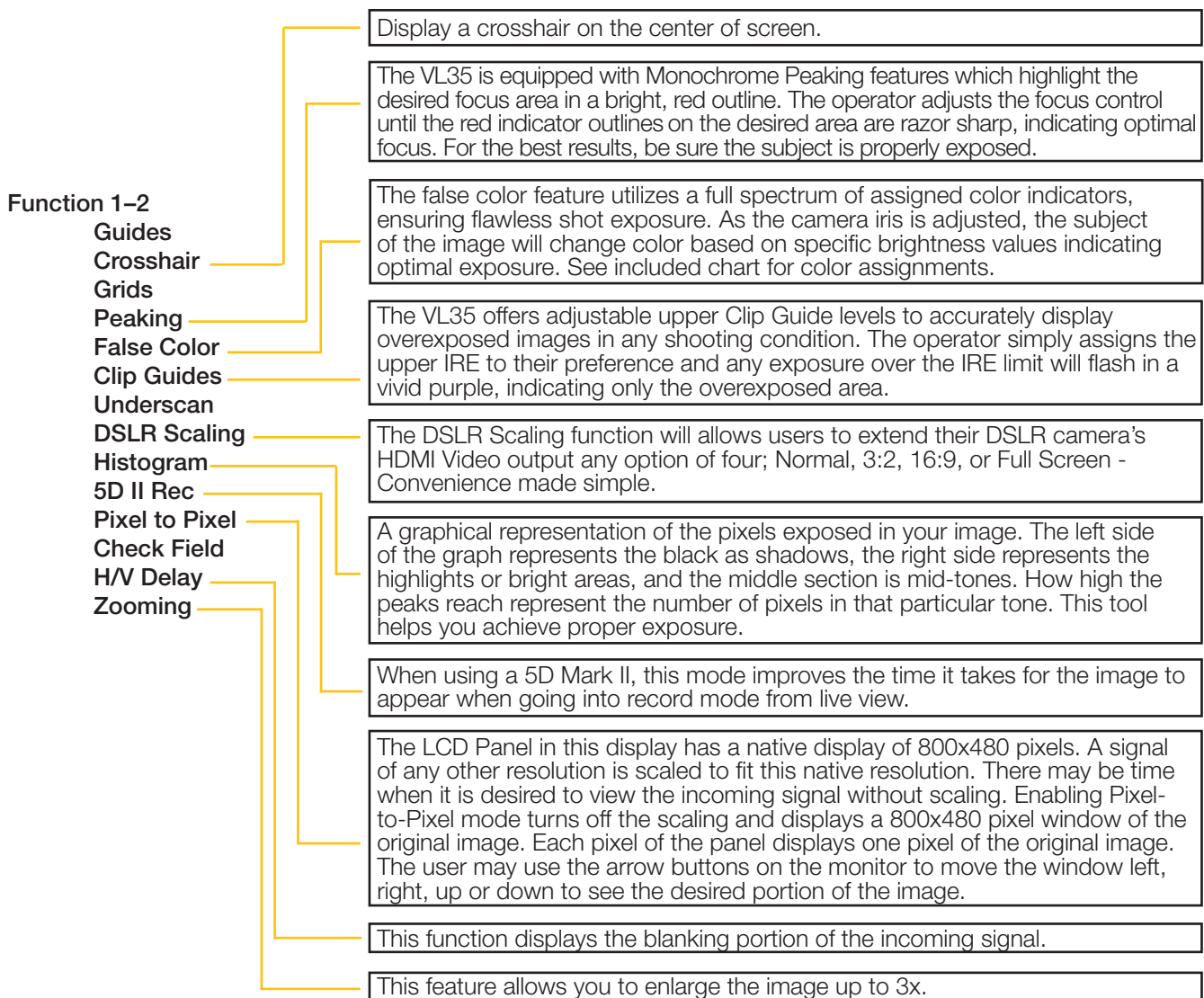

## Specifications

Backlight	LED
Color Depth	16.7 Million
Color System	PAL / NTSC / SECAM (Auto-Detected)
Contrast Ratio	800:1
Diagonal (Inch)	3.5 In.
Dimensions	4.0 x 2.9 x 0.7 In. / 104 x 74.2 x 20.1mm
Inputs	HDMI, Composite
LCD Brightness	315 cd/m2
Material	Heavy Duty Plastic
Operating Volts	DC 6 - 24V
Outputs	HDMI
Power Consumption	2.5W
Resolution	800 x 480
Surface Treatment	Anti-Glare
Viewing Angle	160 (H) 160 (V)
Weight	0.2 lbs / 100 g
Shipping Dimensions	3.5 x 7.75 x 6.25 In. / 8.8x19.6 x 15.8 cm
Shipping Weight	2 lbs

## Supported Video Signals

HDMI	720x480i & 720x480p @ 59.94, 60 Hz
	720x576i @ 50 Hz
	1280x720p @ 23.97, 24, 25, 29.94, 30, 50, 59.94, 60 Hz
	1920x1080i @ 50, 59.94, 60 Hz
	1920x1080psf @ 24, 25, 29.97, 30 Hz
	1920x1080p @ 23.97, 24, 25, 29.94, 30, 50, 59.94, 60 Hz
	3840x2160p @ 24, 25, 30 Hz
	4096x2160p @ 24 Hz
Composite	NTSC-M, NTSC-J, NTSC-4.43
	PAL B/G H I D, PAL M, PAL N
	SECAM

## **Learn More**

More dynamic information at official website: [www.ikancorp.com](http://www.ikancorp.com)

## **Support**

Contact email: [support@ikancorp.com](mailto:support@ikancorp.com)

### **CONDITIONS OF WARRANTY SERVICE**

- Free service for one year from the day of purchase if the problem is caused by manufacturing errors.
- The components and maintenance service fee will be charged if the warranty period is expired.

Free Service will not be Provided in the Following Situations:(\*Even if the product is still within the warranty period.)

- Damage caused by abuse or misuse, dismantling, or changes to the product not made by the company.
- Damage caused by natural disaster, abnormal voltage, and environmental factors, etc.