

PT4200-P2P



Ikan P2P Interview System with 2 x 12" Teleprompters



What's Included

- 2 x PT4200
- 2 x 25 ft HDMI Cable



Overview

When using the Ikan's P2P Interview System, the interviewer and the interviewee are able to look directly into the camera lens while still seeing and looking directly at an image of each other. This equates to a natural one-on-one interview style which is also, because of the direct eye contact, much more involving for the audience. When the interviewer asks a question, he or she is looking right into the eyes of the viewer. When the interviewee answers the question, he or she is also looking directly into the eyes of the audience and in essence giving his or her answers to them. No longer is the audience sitting off to the side and observing the interview; they become a part of the interview.

Teleprompter Assmeby Setup

Step 1

Attach the two 15mm rod monitor adapters to back of the monitor's VESA mounts with the 4 screws using the smaller hex key.



Step 2

Using the larger hex key loosen the rod clamps.



Step 3

On the teleprompter base loosen the top 4 screws holding the rods in place.



Step 4

After loosening the following two screws on the base pull the rods out to accommodate the monitor. Tighten all 6 screws after rods are extended.

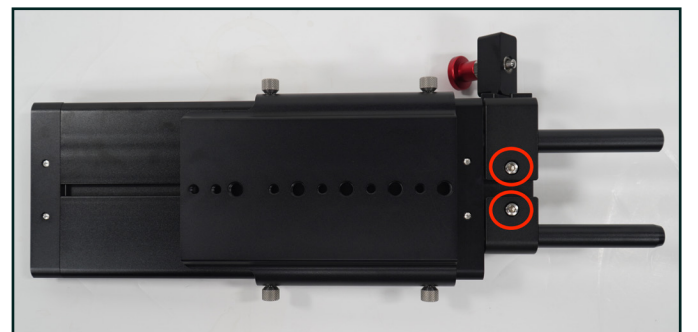

Step 5

After tightening the rods, slide the monitor into the teleprompter base. Leave slight room for the teleprompter bracket and glass to slide in.

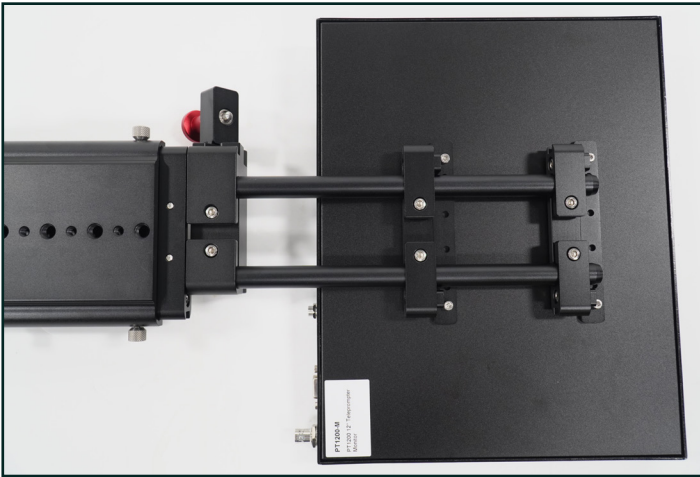

Step 6

Pull the red knob to insert the teleprompter bracket with glass into the teleprompter base.



Step 7

Tighten the silver knob to hold the teleprompter bracket in place.



Step 8

Slide the monitor completely in and tighten the four screws to lock the monitor in place.

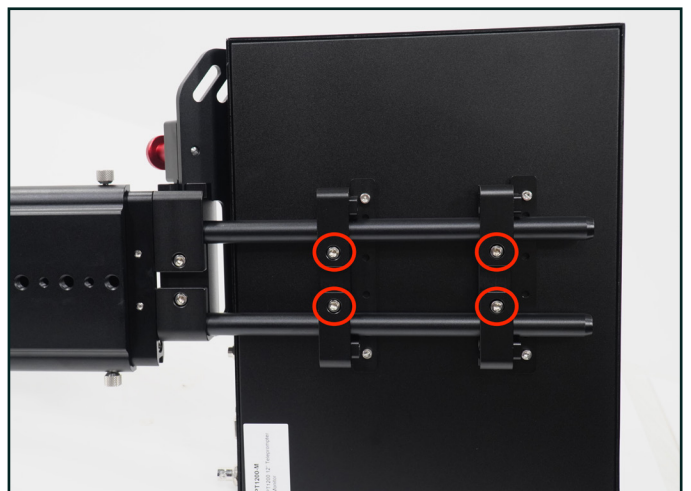

Step 9

Attach the magnetic teleprompter hood with boot.



Step 10

Slide the dual sided riser into the directional channel of the teleprompter base. Larger or taller cameras should insert the lower side facing glass, while smaller cameras should insert with higher side.



P2P Interview/Interviewee Setup

After both teleprompters have been setup and placed on tripods/pedestals, using one of the HDMI cables connect it to the camera on teleprompter 1 (interviewer) to the HDMI input port of monitor on teleprompter 2 (interviewee). Using the other HDMI cable connect it to the camera of teleprompter 2 (interviewee) to the HDMI input port of monitor on teleprompter 1 (interviewer).

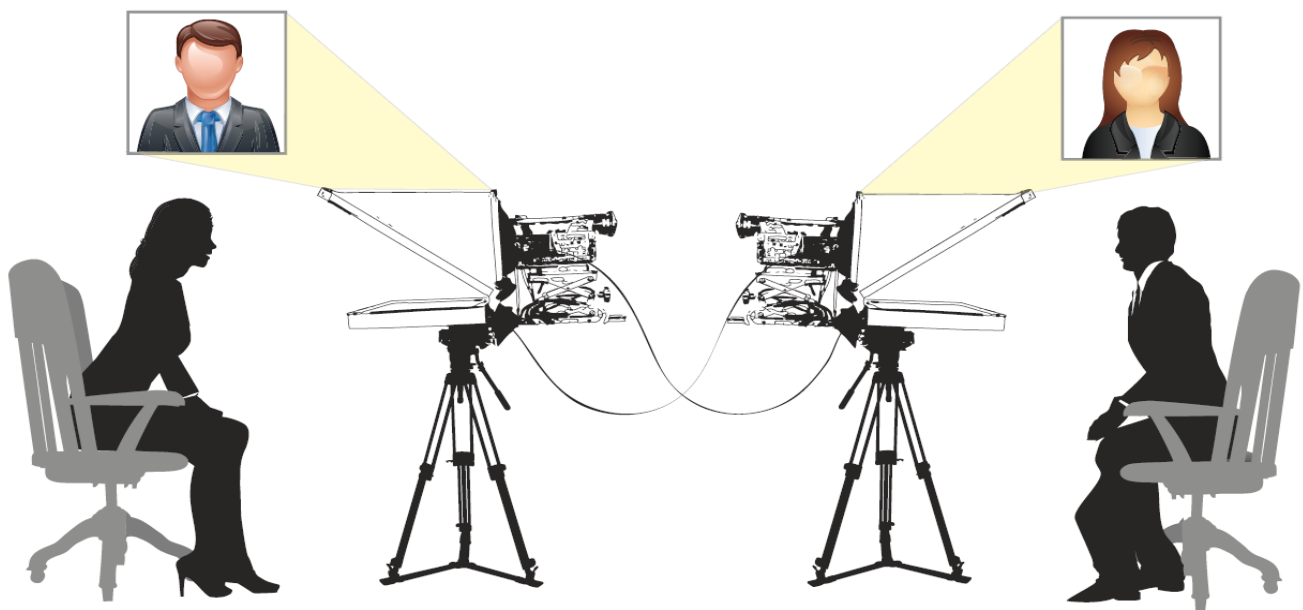

Monitor Ports

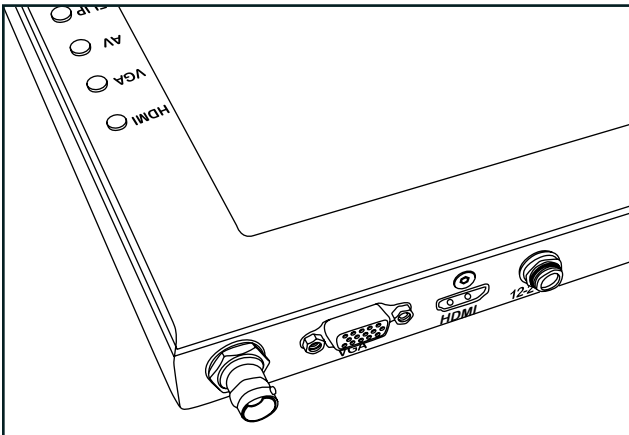

- BNC – AV Composite Input
- VGA – Video Graphics Array DE15 Connection
- HDMI – High-Definition Multimedia Interface Input Connection
- Power Port – 12-24v Input

Monitor Menu Settings

Video Config

- Contrast (White Level)
- Brightness (Black Level)
- Tint (Chroma Hue)
- Chroma (Chroma Saturation)
- Sharpness (Detail)
- RGB Setup – Manually configure RGB
- Return

System Config

- Menu Duration – Set duration of how long menu stays on screen
- Video Ratio – Set screen aspect ratio 16:9 or 4:3 (4:3 is native resolution, 16:9 will create black bars)
- Flip-H – Assign toggle button to flip image horizontally
- Flip-V – Assign toggle button to flip image vertically
- Reset – Factory reset
- Return

PC Setup (Only available for VGA)

- H-Position – Adjust horizontal position
- V-Position – Adjust vertical position
- Auto – Monitor automatically adjust position
- Return

Exit

How to set-up FLIP button feature:

1. Press MENU button
2. Navigate to SYSTEM CONFIG.
3. Navigate to FLIP-V or FLIP-H
4. Change FLIP-V and/or FLIP-H to "ON"
5. Exit MENU
6. The FLIP button should now be activated and can be pressed to mirror the image Horizontally or Vertically
7. When FLIP-H is ON, the image will flip Horizontally
8. When FLIP-V is ON, the image will flip Vertically
9. If both are ON, the FLIP button will toggle both Horizontal and Vertical flip

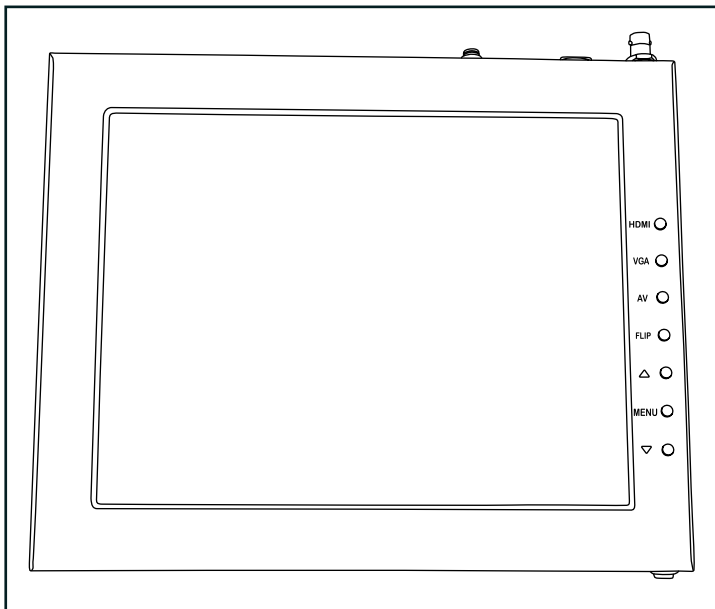

- HDMI – Switch HDMI input
- VGA – Switch to VGA input
- AV – Switch to composite BNC input
- Flip – Toggle image flip
(Can be set to horizontal, vertical, or both via menu)
- Up Arrow – Toggle up to adjust setting
- Menu – Access to monitor settings
- Down Arrow – Toggle down to adjust setting

Foam Case

To make your teleprompter more portable, we packed it in a reusable, high-quality foam. The shape and size of the foam was designed to fit into Ikan's PT-CASE-ELITE. Hard Cases only included in Travel Kit.



**** DO NOT THROW AWAY FOAM CASE ****

Specifications

Aspect Ratio	4:3
Brightness	350 cd/m2
Build Material	Aluminum / Steel
Contrast Ratio	500:1
Input Signal	Composite BNC, VGA, HDMI
Reading Range	13 ft.
Resolution	1024 x 768
Screen Size	12 in.
Viewing Angle	160 degrees (horizontal/vertical)

Features

- Includes two teleprompters
- Monitor that supports image flip (vertical and horizontal)
- High-quality American made 70/30 beam splitter glass
- Screen readable from up to 13'
- Works with many different sized camera
- Easy balancing with adjustable base
- Perfect size for portability and view-ability
- Ships in Reusable Foam for Easy Transport
- Includes MAC and PC Software
- HDMI, VGA, and Composite

Optional Accessories

Some other products that work well with the PT4200-P2P available from Ikan include:

PT-CASE-ELITE Hard Case for PT4200 Teleprompters

Learn More

More dynamic information at official website: www.ikancorp.com

Support

Contact email: support@ikancorp.com

CONDITIONS OF WARRANTY SERVICE

- Free service for one year from the day of purchase if the problem is caused by manufacturing errors.
- The components and maintenance service fee will be charged if the warranty period is expired.

Free Service will not be Provided in the Following Situations:

(Even if the product is still within the warranty period.)

- Damage caused by abuse or misuse, dismantling, or changes to the product not made by the company.
- Damage caused by natural disaster, abnormal voltage, and environmental factors, etc.

©2020 Ikan International. All rights reserved.

