

PT-ELITE-LS-TK



Elite Universal Tablet & iPad Teleprompter for Light Stand with Rolling Case



What's Included

- 1 x Rolling Case
- 1 x Glass Frame Assembly
- 1 x Magnetic Hood
- 1 x Tablet Holder Extension
- 1 x Universal Tablet Holder
- 2 x D-Ring

CHECKED BY

What's Included

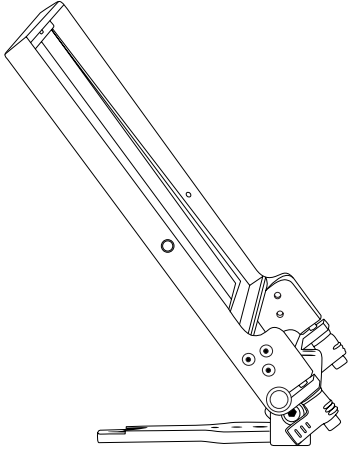

Glass Frame Assembly

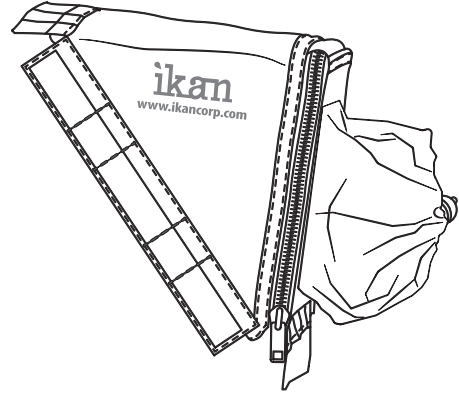

Magnetic Sunhood

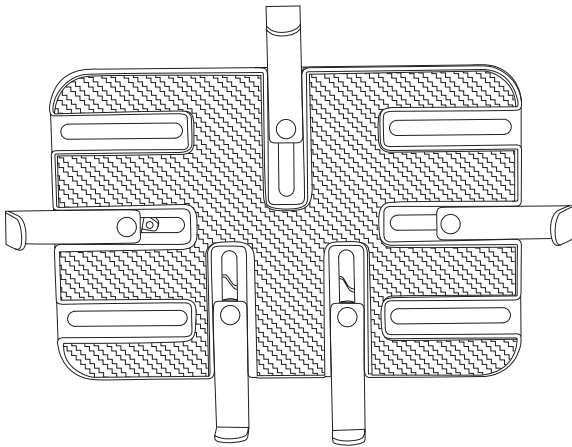

Tablet Holder

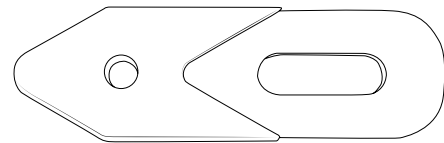

Large Tablet Holder Extension & D-Ring

How to Assemble

1. Attach tablet mount to glass frame assembly. Figures 1a, 1b, 1c.

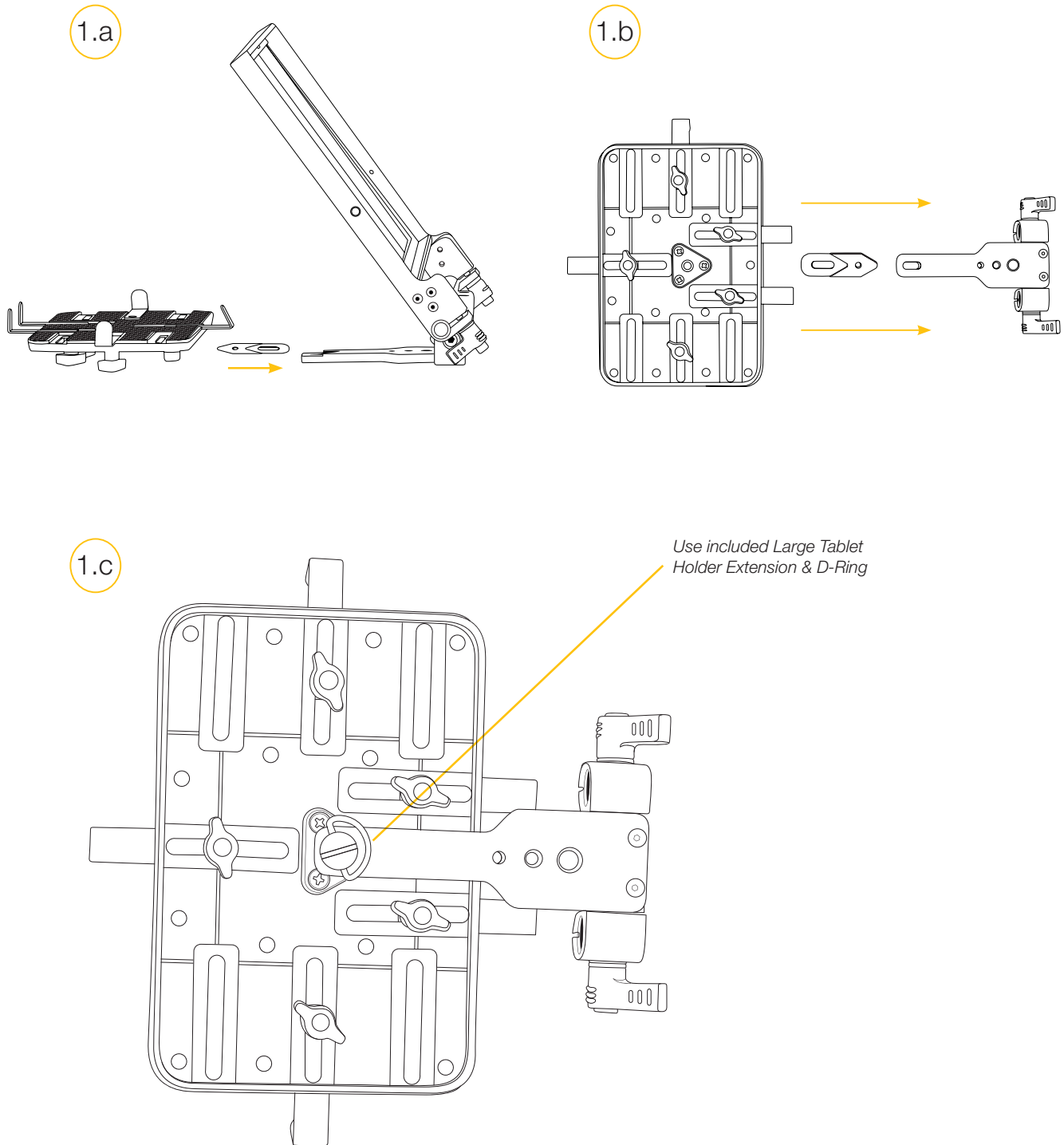

Tighten & loosen thumb screws to adjust glass frame. Ideal angle is 45 degrees.
Attach magnetic hood to glass frame.

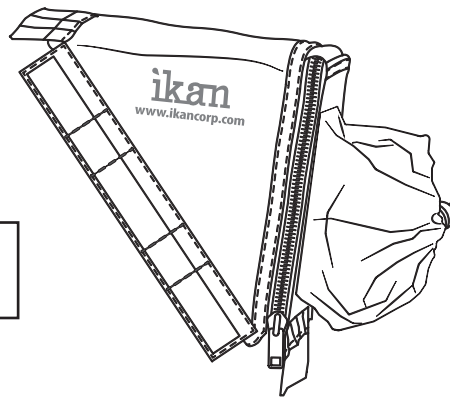

NOTE: Glass can be removed by unscrewing the three (3) screws around glass frame.

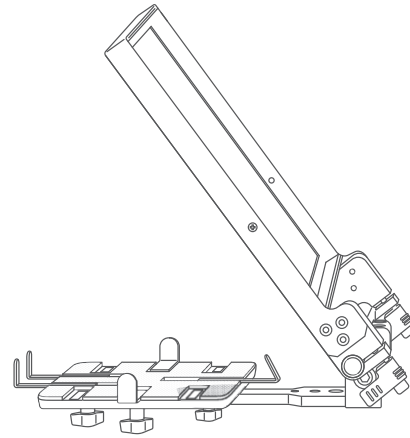

DO NOT THROW AWAY FOAM INSERT.

The PT-ELITE-LS-TK comes packaged in high quality custom-cut foam. It is sized perfectly to fit inside a waterproof case.

Software Options

Windows: Choose from PrompterPro from Ikan, or from multiple third party options in the Windows Store or on the Web.

iOS: Download Ikan Elite Prompter App from App Store

Android: Choose from multiple 3rd party options on Google Play Store

Specifications

Fixture Specifications	
Build Material	Aluminum / Steel
Dimensions	22 x 10.5 x 12 in.
Reading Range	20 ft
Shipping Dimensions	7 x 16 x 20 in.
Shipping Weight	10 lbs

Optional Accessories

Some other products that work well with the PT-ELITE-LS-TK available from Ikan include:

ELITE-REMOTE Bluetooth Teleprompter Remote for PT-ELITE Prompters

Learn More

More dynamic information at official website: www.ikancorp.com

Support

Contact email: support@ikancorp.com

CONDITIONS OF WARRANTY SERVICE

- Free service for one year from the day of purchase if the problem is caused by manufacturing errors.
- The components and maintenance service fee will be charged if the warranty period is expired.

Free Service will not be Provided in the Following Situations:(*Even if the product is still within the warranty period.)

- Damage caused by abuse or misuse, dismantling, or changes to the product not made by the company.
- Damage caused by natural disaster, abnormal voltage, and environmental factors, etc.

©2018 ikan Corporation. All rights reserved