

# LS-575SPX

## QUICKSTART GUIDE

575 Watt HMI Super Spot Kit (*Lightstar*)



### What's Included

- 1 x 575 Watt Light Fixture
- 1 x Barn Doors
- 1 x 575 Electronic Ballast
- 1 x 4' Head to Ballast Cable
- 1 x Yoke
- 1 x Gel Holder
- 1 x 5 Insert Lens System (1x Spot, 1x Flood, 1x Narrow Flood, 1x Super Flood, 1x Frost)

<b>CHECKED BY</b>

# ikan

[www.ikancorp.com](http://www.ikancorp.com)

[support@ikancorp.com](mailto:support@ikancorp.com)

713.272.8822

© 2016 ikan Corporation. All rights Reserved

# Instructions & Safety Precautions

1. Before connecting the fixture to the main power, set lights. Disconnect from main power before moving the fixture. Do not pull the main connecting wire from power source. Any product repairs must be performed by professional ikan personnel. Users must use correct wattage globes for fixture.
2. Before lighting fixture lights, main power connection must be stable and operating correctly.
3. When adjusting or replacing the lamp, the fixture must be disconnected from main power.
4. When connecting to the AC connection you must first shut down the electronic ballast. To avoid possible harm caused by the fixture's ballast, we recommend using Lightstar cables and connectors with the correct fixtures.
5. Electronic ballasts and DIN meet DIN EN605981 EN60065 safety standards.
6. Grid voltage should not exceed the "technical indicators" set forth in the manual. Prior to the use of electronic ballasts, electronic check voltage network and cable wiring is correct. When AC voltage is less than prescribed values then the use of the unit ma be prohibited for users and production.
7. Fixture lamp ambient operating temperature must ensure that 20°C (68°F) ~ + between.
8. Products must be placed on a solid, flat and dry surface. Surface temperature should be less than 50°C (120°F). Avoid direct sunlight by then irradiated, and at high humidity and with explosive gas in the work environment.

## Product Overview

Lightstar 575W Super Spot HMI Lighting Fixture

The Lightstar Super Spot is intended for professional studio and location use and may be operated by qualified personal only.

Please read the following instructions carefully before using the fixture for the first time. For the safety of all parties please follow all instructions of lamp and ballast manufactures also. Please keep the operating instructions for future use.

The Lightstar 575W Super Spot combine the fixture and ballast in a simple attached unit. The ballast attaches directly to the yoke of the light. The quick connection of the light to the ballast is simple with the 4 foot head cable that comes with the 575W Super Spot kit.

### **Lightstar 575 Super Spot fixture has the following advantages:**

1. The ballast power supply unit safely connects to the light fixture so the system is convenient and placement quick.
2. The Par Lens System gives the user a Spot, Flood, Narrow Flood, Super Flood, and Frost Lens to choose from.
3. The light's body structure is more compact, smaller, and efficient.
4. The ballast can be attached directly on the yoke of light. This makes the attachment of the head to ballast cable very convenient.
5. On the integrated ballast pack the dimming can be set from 50%-100%.

# Product Description

## Lightstar 575W Super Spot HMI Lighting Fixture

- Step 1: 575W Super Spot cap Press the button on the back cover, while counterclockwise rotation of the cover, and then remove the back cover. Install the lamp in a porcelain seat, using a firm push to install the bulb.
- Step 2: The electronic ballast is fixed at 575W Super Spot yoke. Plug the head cable into the electronic ballast, the other end is connected to the back fixture.
- Step 3: The light can be attached to a Baby 5/8" pin on a stand or attached to a grid with a C-Clamp.
- Step 4: Finally, the power cord connects to the electronic ballast, and the other end connects to the AC power socket.

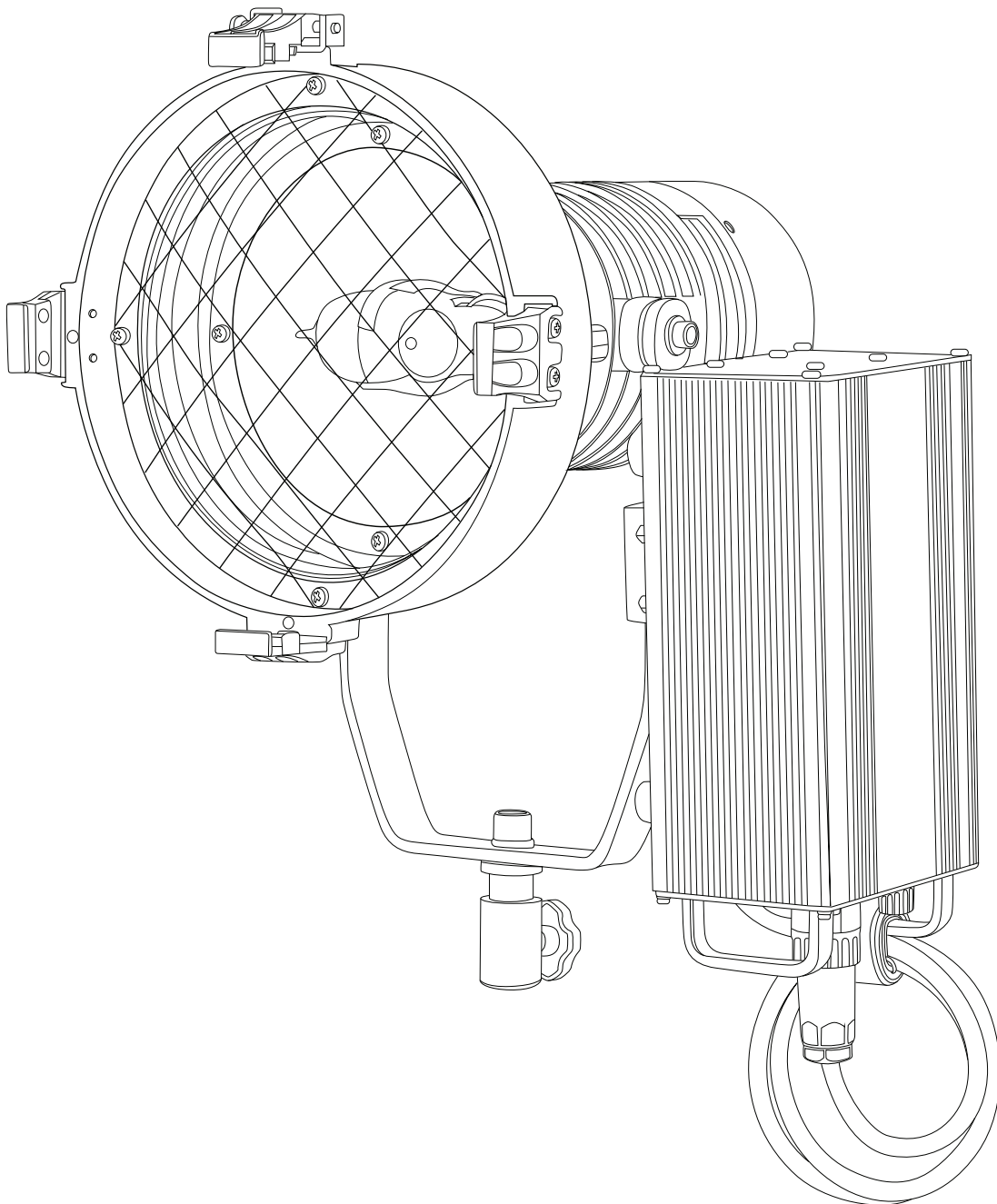

## Product Accessories

Lightstar 575W Super Spot HMI Lighting Fixture

5 Sets of Lens to adjust the Beam Degree and Angle

No Lens Beam Angle:	5 Degree
Spot Lens Beam Angle:	9 Degree
Narrow Flood Beam Angle:	11 - 22 Degrees
Flood Beam Angle:	21 - 41 Degrees
Super Flood Beam Angle:	42 Degrees
Frost Beam Angle:	35 Degrees

## Lighting Illumination Steps

Check the start button on the operation panel “0” so that it is in the pressed down position.

The fixture to ballast cable is connected and locked into place.

Connect the ballast power plug to the AC Power.

After the above operations are correct, the start button on the operation panel “1” is pressed, so that it's in the ON position.

When the AC power voltage is live, the voltage indicator will be illuminated with a Green light.

## Output Power Adjustment

The HMI Bulb is installed.

The power and output of the lamp can be adjustment by dimming the operating knob on the front panel. Power can be adjusted between 50% and 100% on the ballast.

## FAQ's & Answers

1. The required ballast input voltage can automatically match the AC power.
  - A. Lightstar electronic ballasts can be used with either 110V or 220V AC power.
2. If the ballast suddenly stops working after working for some time.
  - A. The lamp itself is broken, or end of life.
  - B. The ballast fan may be bad; in this case the user must wait for the ballast temperature to cool down before starting the unit again.
  - C. If the AC voltage exceeds the specified input voltage on the ballast this will cause the breaker to engage.
  - D. An unexpected surge/spike of electricity will cause the ballast protection circuit to engage and cause the ballast to not function.
  - E. If the ballast stops working due to voltage surge/spike its best to turn off the ballast than turn the breaker back on and push the Action/Close button. These will reactivate the ballast for reuse.

## Specifications & Photometrics

LS-575SPX	
Input Voltage Range	100-240 VAC
Maximum Input Current	7-3.6 A
Color Temperature	5600K
Dimensions	356 x 264 x 272 mm
Flat Lens Dimensions	205 mm
Weight	10.5 kg
Protection Level	IP22
Certification	CE

LLAN-19 Photometrics				
	Spot	Narrow Flood	Flood	Super Flood
10 Feet	82800 LUX	33600 LUX	9500 LUX	7200 LUX
	7692.3 FC	3121.5 FC	882.5 FC	668.9 FC
16 Feet	29900 LUX	12000 LUX	3400 LUX	2600 LUX
	2777.8 FC	1114.8 FC	315.8 FC	241.5 FC
32 Feet	7500 LUX	3040 LUX	850 LUX	650 LUX
	696.7 FC	282.4 FC	78.4 FC	60.3 FC

## Optional Accessories

Some other products that work well with the LS-575SPX available from Ikan include:

- KCP-703** Stage Clamp w/ 16mm Stud
- SW-04** Safety Wire
- CV600** Chrome Exposure / Spectrometer from UPRTek

## Learn More

More dynamic information at official website: [www.ikancorp.com](http://www.ikancorp.com)

## Support

Contact email: [support@ikancorp.com](mailto:support@ikancorp.com)

### CONDITIONS OF WARRANTY SERVICE

- Free service for one year from the day of purchase if the problem is caused by manufacturing errors.
- The components and maintenance service fee will be charged if the warranty period is expired.

Free Service will not be Provided in the Following Situations:(\*Even if the product is still within the warranty period.)

- Damage caused by abuse or misuse, dismantling, or changes to the product not made by the company.
- Damage caused by natural disaster, abnormal voltage, and environmental factors, etc.