

# LS-1200TE

## QUICKSTART GUIDE

1200 Watt HMI Fresnel Kit (*Lightstar*)



### What's Included

- 1 x 1200 Watt Fixture Head
- 1 x 575/1200 Watt Ballast
- 1 x 8m Heavy Duty Head to Ballast Cable
- 1 x Yoke
- 1 x Barn Doors
- 1 x Gel Holder

CHECKED BY

# ikan

[www.ikancorp.com](http://www.ikancorp.com)

[support@ikancorp.com](mailto:support@ikancorp.com)

713.272.8822

© 2016 ikan Corporation. All rights Reserved

## Instructions

1. The Lightstar LS-1200TE HMI 1200Watt Kit is a compact, dual power, Fresnel light with a multi-use 575/1200 Watt Ballast. The fixture uses 1200w 120v G38 socket metal handle lamps.

## Safety Precautions

1. The 1200w fixture has been designed for professional use and must be operated by qualified personnel only.
2. Electrical Connections: Do not attach the ballast directly to any electrical mains. The ballast has the proper three pin grounded plug that works with a standard AC socket.
3. The 1200w fixture can only be used with the Lightstar 575w/1200w electronic ballast.

## Working Conditions

- The best working position max tilting is 90° from horizontal.
- Ambient temperature usage +/- 45° C (113°F) Max Limit.
- Minimum distant in which the fixture can be to inflammable objects is 2 feet along any side.
- Do not cover the ventilation holes on the fixture housing. They are necessary for proper ventilation.
- Use only original parts and accessories from Lightstar.
- Before hanging the fixture, make sure the suspension points are properly rated to handle the weight of the fixture.
- It is always advisable to add a safety cable or chain through the yoke to properly suspend the fixture in place.

**Warning: DO NOT USE THE LS-1200TE IN A SPACE WITH FLAMMABLE SUBSTANCES.**

**WARNING: UV Risk / Health Risk.** The lamps that are used with the LS-1200TE emit an amount of UV Radition which can be dangerous to human health if not properly shielded against.

**THE FIXTURE MUST NEVER BE USED IN SITUATION WHEN DIRECT LIGHT EMISSIONS FROM THE LAMP CAN OCCUR.** (Ex: no front glass, no internal mirror, damaged front housing).

# Installation Instructions

Connecting the fixture to the ballast and energizing the ballast with power.

1. The ballast and the fixture are compatible Lightstar products.
2. The ballast is appropriate for the AC power that will energize the ballast and fixture. (Voltage & Frequency)
3. The ballast is properly grounded and the main power switch is in the OFF position.
4. The Lamp is fitted into the fixture.
  - a) The lamp is the proper wattage for the fixture.
  - b) There is nominal power equal to the ballast.
  - c) The AC power is not higher than the max power of the ballast.
5. The safety glass shield is in good working order with no cracks or anomalies. The Safety glass is in the proper position and there is safety wire guard.

**WARNING: SHIELD GLASS WILL NEED TO BE CHANGED IF THEY HAVE BECOME VISIBLY DAMAGED TO SUCH AN EXTENT THAT THEY ARE NO LONGER EFFECTIVE. (Ex: The fixture has ricks in the glass, or deep scratches).**

## Lamp Installation & Replacement

A) A user needs to ensure the fixture is disconnected from the main power supply.

WARNING! Wait at least 5 minutes from switching off the fixture to open the protection shield. This will avoid risk of injury from a lamp explosion.

WARNING!! Lamp will still be HOT to the touch even after the allotted lamp rest period. Thermal gloves are recommended for working with the fixture and bulb.

B) The user should check to see that the new lamp is the correct wattage.

C) The user will release the lamp clamp lever inside the front of the fixture.

D) To replace the lamp pull up and out to remove the old lamp.

1) Re-lamp procedures: Do not touch the bulb with your bare-hands this can cause oil to accumulate on the glass and reduce the performance of the lamp life. The plastic/foam cover which protects the lamp should not be removed until after the lamp is fitted into the fixture. If bulb becomes dirty due to hand contact or from any contaminant, it can be cleaned with a cloth moisten with alcohol.

E) Re-tighten the lamp clamping device.

F) Close the lens door and securely latch.

Usable lamps from Manufacturer	Model
Osram	HMI 1200 / SE
Philips	MSR 1200 / HR

NOTE: Other lamps may be used as long as the meet the technical specs of the LS-1200TE)

## Periodic Fixture Inspection

1. The condition of the internal wiring and ceramic base will need to be inspected and tested every 4000 working hours or at least once a year. This frequency may need to be increased if the fixture has endured rough treatment. All internal components should only be replaced with Lightstar spare parts.
2. The lamp should be checked every 100 working hours. The lamp should be changed if the lamp becomes deformed or damaged otherwise explosion might occur. Defer to instruction provided by the lamp manufacture.
3. Always check the safety shield before every use.
4. All high-voltage components (ex: voltage wires, lamp ceramic, external shield, igniter must be inspected every 100 working hours or at least once a year).
5. Outer door hinges and latching system must be checked every 250 working hours to insure proper seating of the safety shield. This will allow inspections of accessories and the holding clamps.
6. The condition of the internal mirror must be maintained every 250 working hours. It must be replaced whenever it becomes either cracked or broken. It is essential for the performance of the fixture.

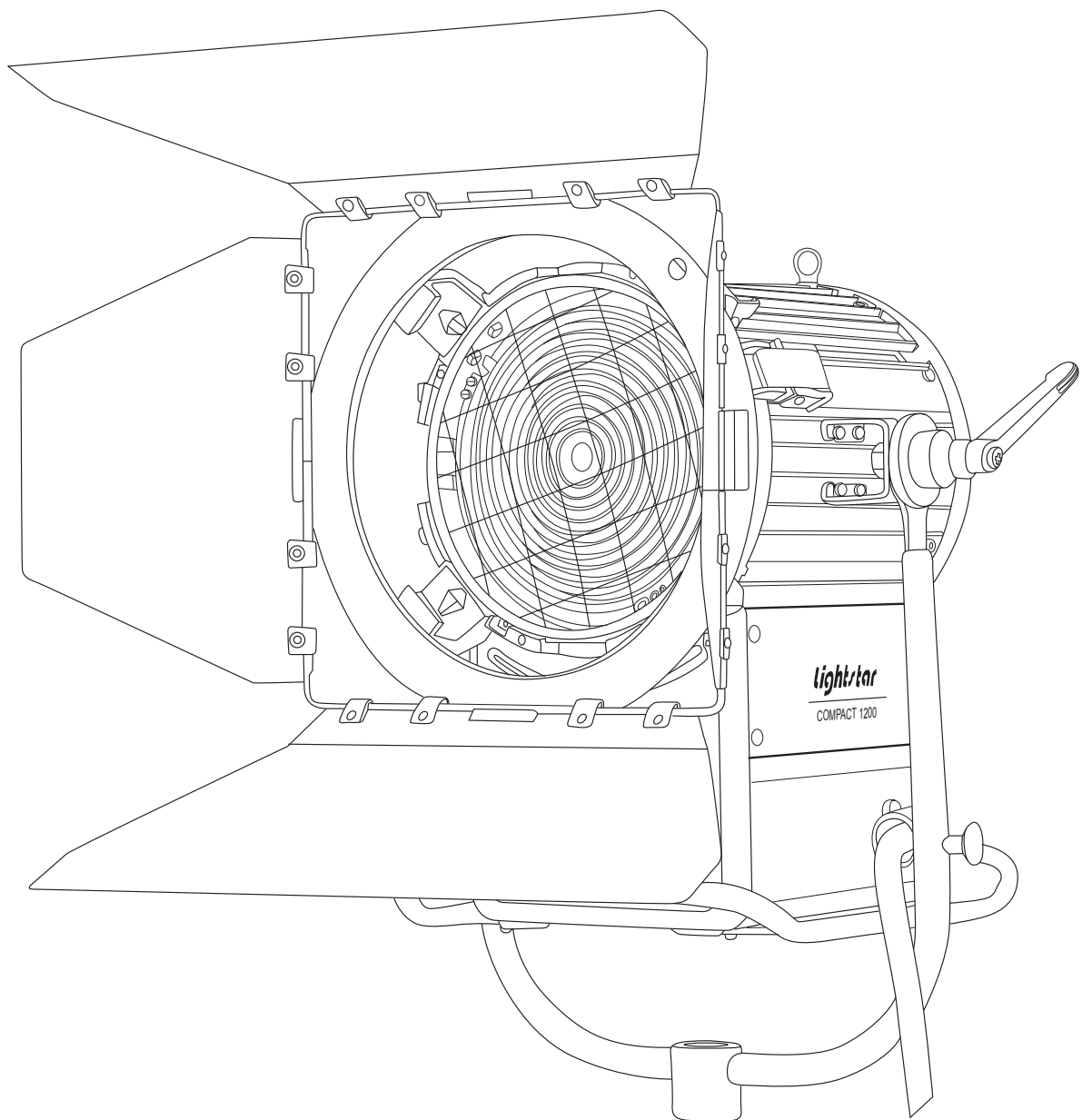

## Specifications & Photometrics

LS-1200TE	
Head Type	LS-1200TE
Rating	1200 Watt
Light Source	Metal Halide 1200W / SE
Power Supply	Electronic Ballast 575W
Voltage Range	95V-120V
Lamp Base / Bulb	HMI 1200 / 120V / G38 / MSR 1200 HR
Dimming	50-100%
Lens Size	Fresnel 6.8" Lens
Focusing	Knob Controlled
Beam Angle	6°-58°
Cooling System	Air Cooled
Yoke	Cast Aluminum with 1 1/8" Pin
IP Class	IP23
Fixture Size	23 x 16 x 12 In.
Fixture Weight	24.2 lbs
Shipping Dimensions	26 x 18 x 18" / 66.04 x 45.72 x 45.72 cm
Shipping Weight	59 lbs / 26.7 kg

LS-1200TE Photometrics		
	6 Degrees	58 Degrees
13 Feet	46880 LUX	3125 LUX
	4355.2 FC	292.8 FC
16 Feet	20800 LUX	1390 LUX
	1032.3 FC	129.1 FC
19 Feet	11200 LUX	780 LUX
	1086.9 FC	72.4 FC

## Optional Accessories

Some other products that work well with the LS-575SPX available from Ikan include:

- KCP-703** Stage Clamp w/ 16mm Stud
- SW-04** Safety Wire
- CV600** Chrome Exposure / Spectrometer from UPRTek

## **Learn More**

More dynamic information at official website: [www.ikancorp.com](http://www.ikancorp.com)

## **Support**

Contact email: [support@ikancorp.com](mailto:support@ikancorp.com)

### **CONDITIONS OF WARRANTY SERVICE**

- Free service for one year from the day of purchase if the problem is caused by manufacturing errors.
- The components and maintenance service fee will be charged if the warranty period is expired.

Free Service will not be Provided in the Following Situations:(\*Even if the product is still within the warranty period.)

- Damage caused by abuse or misuse, dismantling, or changes to the product not made by the company.
- Damage caused by natural disaster, abnormal voltage, and environmental factors, etc.