

BZ1000-PRO

USER'S GUIDE

Blitz 1000 Pro Wireless Uncompressed Zero Delay HD Video System



What's Included

- 1 x Transmitter
- 1 x Receiver
- 1 x Sony L Series Battery Plate (*Installed on TX*)
- 1 x V-Mount Battery Plate (*Installed on RX*)
- 8 x 5 GHz Omni-Directional Antennas (*SMA Female*)
- 2 x P-Tap to LEMO Cables
- 1 x 6 In. Articulating Arm
- 1 x Clamp
- 1 x Shoemount Adapter for Transmitter



■ Product model and standard:

The Long Range Wireless HDMI/SDI Transmission Blitz 1000 utilizes today's most advanced wireless video transmission technology, which supports broadcast quality and uncompressed HD video signal transmitted with zero delay. The Blitz 1000 includes one transmitter and one receiver, where the transmitter provides a 3G/HD SDI input and an HDMI input, and the receiver also provides a 3G/HD SDI output and an HDMI output. The Blitz 1000 has 2 external antennas on the transmitter and 5 external antennas on the receiver's side. Both the receiver and transmitter feature a frequency selection knob, which provides a maximum of 10 workable frequency channels (According to FCC norm, the United States can use frequency from 0~4) , and supports a maximum of 4 sets working simultaneously. The Blitz 1000 can accept a wide range of DC power inputs and includes a Sony L series battery plate on the transmitter and a V-Mount plate on the receiver. The aluminum case was designed to be light weight yet rugged. It also provides mounting points for Ikan's Quick Mount System that will make mounting the Blitz 1000 to other equipment easy.

■ Main features:

- Supports HDMI 1.3
- HDMI and 3G-SDI Inputs and Outputs
- Up to 1080p 60Hz Uncompressed with Zero Delay
- AES-128 encryption with air interface HD video data stream
- Supports Point-to-Point, and Point-to-Multi Points Network Topology
- 5GHz ISM Frequency Band, Maximum 10 Selectable Frequency Channels (According to FCC norm, the United States can use frequency from 0~4) that can Coexist with WIFI.
- Maximum Transmission Distance is 1000 ft.
- Signal Indicators for DC Power, Video Status and receiver signal strength
- Includes Sony L Series battery plate for transmitter
- Includes V-Mount battery plate for the receiver
- Machined Aluminum Case for Durability
- Features Ikan's Quick Mount System

Specifications

	Transmitter	Receiver
Interface	SDI Input (BNC Female) ; HDMI Input(Type A female); 2 Antenna port(RP-SMA male) ; DC input (4 pin LEMO female)	SDI Output (BNC Female) ; HDMI Output(Type A female); 5 Antenna port(RP-SMA male) ; DC input (4 pin LEMO female)
Supply Voltage Range	7-36V DC	7-36V DC
Power Consumption	< 6.5 W	< 7.5 W
Size	(L x W x H): 120x 70 x 25mm don't include antennas	(L x W x H): 160x 110 x 25mm don't include antennas
Mass	380g	540g
Input Video Format	HDMI525i, 625i, 720p 50/59.94/60, 1080i 50/59.94/60, 1080p23.98/24/25/29.97/30/50/59.94/60;HDMI Type A SDI:3G, HD, and SD-SDI (auto-selected), SMPTE-259/274/292/296/372/424/425;1x BNC	/
Output Video Format	/	HDMI:525i, 625i, 720p 50/59.94/60, 1080i 50/59.94/60,1080p23.98/24/25/29.97/30/50/59.94/60;HDMI Type A SDI:3G, HD, and SD-SDI (auto-selected), SMPTE-259/274/292/296/372/424/425; 1x BNC
Input Audio Format	SDI embedded 2 channel 24 bit/48KHz	/
Output Audio	/	SDI embedded 2 channel 24 bit/48KHz
Signal Indicator	POWER-Green; VIDEO-Yellow	POWER-Green; Wireless RSSI-Green (5 LEDs); VIDEO-Yellow
Frequency Band	5.1-5.9GHz,configurable with China, North American, Europe,etc	5.1-5.9GHz,configurable with China, North American, Europe,etc
Modulation Mode	OFDM 16QAM	OFDM 16QAM
Transmission Power	Maximum 21dBm	/
Receiver Sensitivity	/	-75dBm
Occupied Bandwidth	40MHz	40MHz
Temperature Range	0~40°C(operating condition); -20~60°C(Storage)	0 ~ 40°C (operating condition); -20~60°C(Storage)
Compliance	FCC; CE.	FCC; CE.

Product Introduction

Transmitter

1. Ikan Quick Mount Receiver
2. RP-SMA male antenna connector
3. Video Input indicator, 1 yellow LED
4. Power indicator, 1 green LED
5. Frequency selection knob, 0-9
6. 3G-SDI input
7. HDMI input
8. DC power switch
9. DC input, LEMO 4-pin B series
10. ¼-20 mount

Receiver

1. Ikan Quick Mount Receiver
2. RP-SMA male antenna connector
3. RSSI Signal Strength Indicator
4. Video input indicator, 1 yellow LED
5. Power on indicator, 1 green LED
6. Frequency selection knob, 0-9
7. 3G-SDI Output
8. HDMI Output
9. DC power switch
10. DC input, LEMO 4-pin B series
11. ¼-20 mount

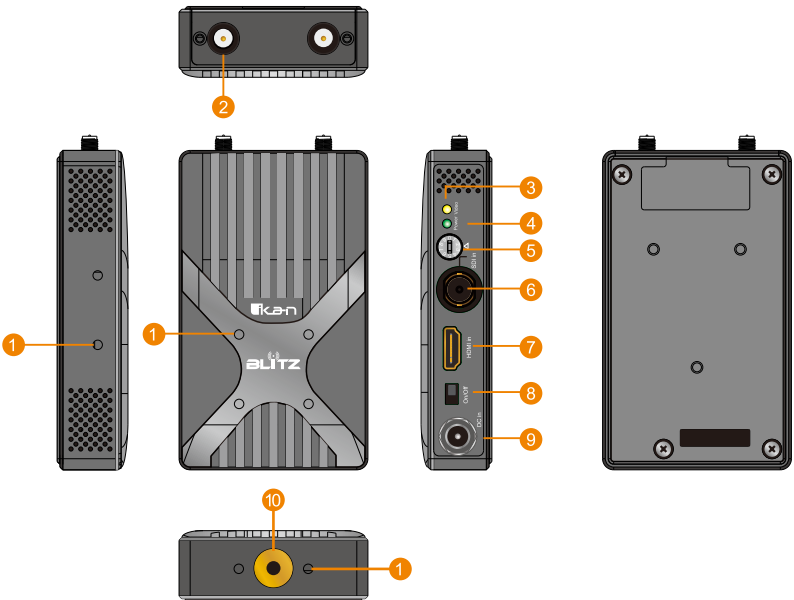

About

Receiver:

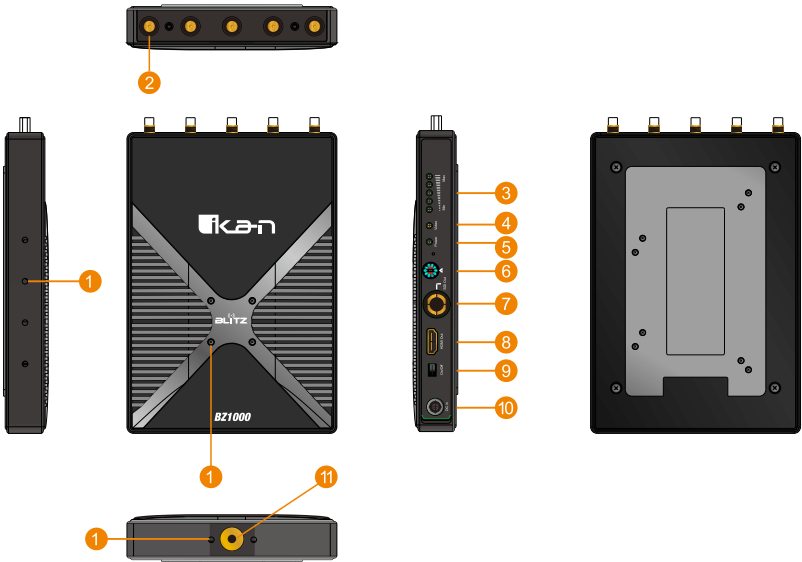

■ Packing list

- 1 x Transmitter w/ Sony L Series Battery Plate
- 1 x Receiver w/ V-Mount Battery Plate
- 8 x 5GHZ Antennas (SMA female)
- 2 x Flat Head Screwdrivers
- 1 x Articulating Arm
- 1 x Shoemount Adapter for Transmitter
- 1 x Clamp
- 2 x P-Tap to 4-pin LEMO Power cable

Installation Details and Cautions

● Transmitter side

- a) Install the two omni-directional antennas to the transmitter's RP-SMA male antenna connectors.
- b) There is a 1/4-20 mount on the bottom of the transmitter. The user can utilize the included shoemount adapter to mount the transmitter on the camera.
- c) Install Sony L Series battery on to the battery plate on the back of the transmitter.
- d) The included P-Tap to LEMO cable can also be used to power the transmitter from a compatible power source such as a pro battery.
- e) All TX installation guidelines see below figure.

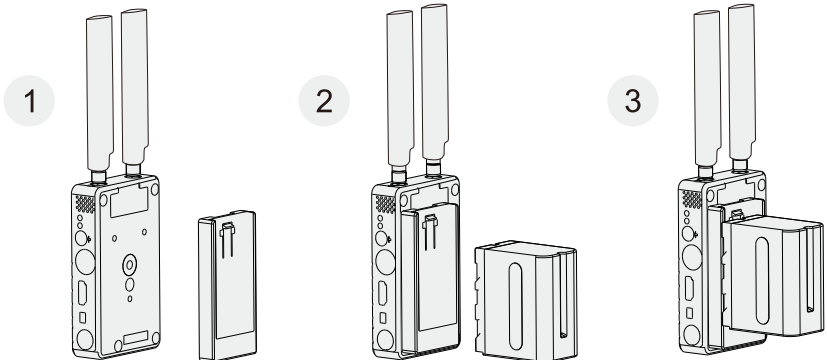

Installation

● Receiver side

- a) Install 5 pcs omni-directional antennas to receiver's RP-SMA male antenna connectors.
- b) There is a 1/4-20 mount at the bottom of the receiver. This can be used to mount the receiver with the included articulating arm.
- c) Install V-Mount battery on to the battery plate on the back of the unit.
- d) The included P-Tap to Lemo cable can be used to power the receiver from a compatible power source.
- e) All RX installation guidelines see below figure.

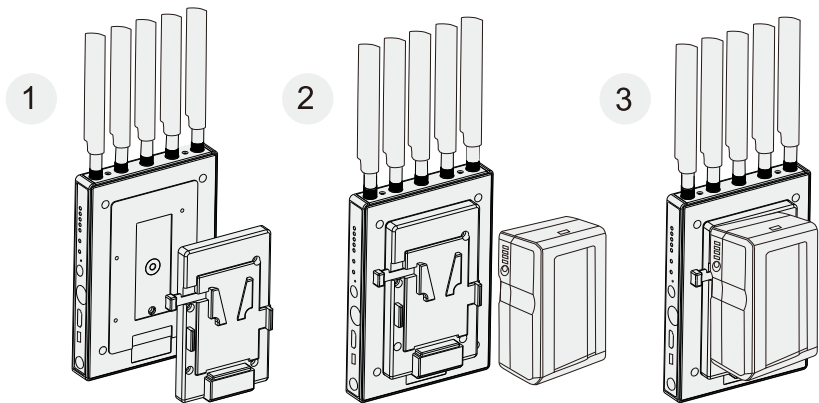

■ Getting started

After following the previous steps:

- Make sure the video source of the camera is ok and the monitor is on the correct input.
- Ensure all the SDI or HDMI cables are connected properly.
- Ensure all antennas are installed. For best performance position the antennas like pictured below:

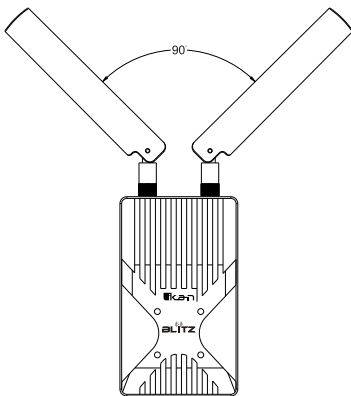

Transmitter

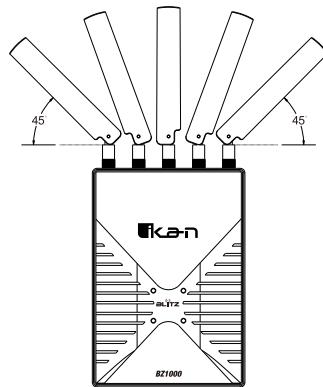

Receiver

- Ensure both the transmitter and the receiver have charged batteries installed or a good DC input via the P-Tap to LEMO cable. Power on the transmitter and receiver. The 'Power' indicator light will illuminate.
- Ensure the frequency knobs of transmitter and receiver are set to the same number. This will make sure the transmitter and receiver working on the same channel.
- If the camera is on and video the input is OK, the transmitter's 'video' indicator light will illuminate.

Operation instruction

- 9) Before the receiver makes a wireless link with the transmitter the 5 'RSSI' indicators and the "video" indicator will be off. When the wireless link is established the 'RSSI' indicators will light up first and indicate the signal strength. If the receiver detects wireless video the 'Video' indicator will light up. Before wireless video is detected the connected monitor will show "Link Connecting".

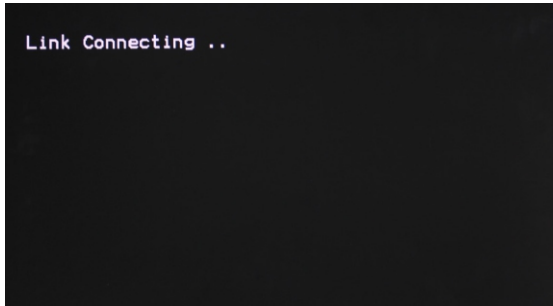

- h) The system will spend 20-30 seconds establishing a communication link. The actual link time will depend on the condition of the currently selected wireless channel. When the wireless link is established the 'RSSI' light will light and indicate the wireless signal strength. The 'video' indicators will light, and then the connected monitor will display the video and audio accordingly.
- i) For the best performance, the transmitter and receiver should be positioned more than 2 meters above the ground and at the same height without obstacles between them. Moreover, it is best to keep the transmitter antennas and the receiver antennas facing the same direction.

The actual transmission distance is also reliant on the current air electromagnetic environment, because the system works in the ISM band, it is exposed to all kinds of 5GHz band air interference, we suggest the users should do a manual frequency sweep by going through the ten frequencies and finding the one with the strongest signal for the best performance.

Transmitter Signal Selection

The transmitter supports both 3G SDI and HDMI video inputs. The system will automatically detect input source. If both SDI and HDMI have valid video inputs the system will take the SDI input as priority.

RSSI Indicators

The receiver will calculate received RF signal strength internally and the 5 “RSSI” LEDs will be used to indicate wireless signal power and quality. The user can observe the RSSI LED status to know if the current wireless link is reliable or not.

Lit RSSI LEDs Volume	Wireless Link Quality	Video Quality
4-5	Strong	Best
2-3	Middle	Good
1 or no lit LED	Weak	Visible Video Noise

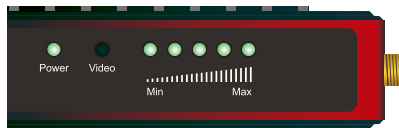

Frequency Selection and Configuration

The wireless system can work in the 5.1-5.9GHz frequency band and be software configured to licensed or ISM bands of different global regions. The side panel of both transmitter and receiver has been feature a frequency selection knob which provides a maximum of 10 frequency channels (According to FCC norm, the United States can use frequency from 0~4) . The BZ1000 also support a maximum of 4 sets working simultaneously. See below frequency knob:

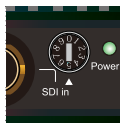

■ Storage Conditions

Products storage temperature should be $-20^{\circ}\text{C} \sim 60^{\circ}\text{C}$. For long term storage please use original hard case, and avoid high humidity or dusty conditions.

■ Maintenance

Warning

To ensure your safety, please choose only Ikan or well-known brands when it comes to choosing the batteries for your system.

■ Common Problems

1. No Output on Display

- a) Check to see if the transmitter and the receiver are receiving power.
- b) Check if the antennas are installed correctly.
- c) Check the “Video” indicator light on the TX. If the light is not on then check your SDI or HDMI source.
- d) Make sure the video format being outputted from your source is compatible with the Bz1000.

2. Poor Output Video Quality

- a) Check if the SDI or HDMI input or output cable is plugged in correctly.
- b) Make sure is 2 to 3 RSSI LEDs lit for better video quality. If there is only 1 RSSI LED lit, that means the wireless signal is weak and the distance between the transmitter and receiver should be shortened.

Health and Safety Disclaimer

■ **This device complies with Part 15 of the FCC Rules. Operation is subject to the following two conditions:**

(1) this device may not cause harmful interference, and (2) this device must accept any interference received, including interference that may cause undesired operation.

Please review FCC's Radio Frequency Safety before the operation at <https://www.fcc.gov/general/radio-frequency-safety-0>.

■ **The following recommendations are made to help maintain RF safety in the Film and Television production environment:**

1. All IKAN transmitters are certified for FCC Part 15 and comply with the following:

a. The transmitter has a legible FCC ID number on the manufacturer's product tag affixed to the unit.

b. The transmitter has not been modified in any way from its original state as delivered by the manufacturer.

c. All transmitter cabling is in good condition and properly attached.

2. The operator should have a clear understanding of the requirements for operating the equipment to maintain compliance with the MPE*(Maximum Permissible Exposure) limits for both controlled and uncontrolled environments.

3. The operator should review the FCC policy on human exposure to radio frequency on FCC's website: <https://www.fcc.gov/general/radio-frequency-safety-0>.

4. When the "unconditionally compliant" condition cannot be met, the operator should mitigate the exposure danger by observing the time limit for RFR exposure so as not to exceed the MPE*.

Health and Safety Disclaimer

5. When a wireless video transmitter is used that is not certified under FCC Part 15 and requires a Special Temporary Authorization (STA) from the FCC, the operator should understand the potential for RFR exposure and take precautions to not exceed the MPE* during the course of work. (Such equipment is typically used for long-range shots and uses high-powered transmitters and high-gain directional antennas.)

6. The operator should be aware of the RF environment to understand what other transmitters may contribute to the total exposure to RFR.

7. Cinematographers should receive specialized training regarding the identification and mitigation of RF Safety issues in the workplace.

By using this product, you hereby acknowledge that you have read this disclaimer and warnings carefully and that you understand and agree to abide by the terms and conditions herein. You agree that you are solely responsible for your own conduct while using this product, and for any consequences thereof. You agree to use this product only for purposes that are proper and in accordance with all applicable laws, rules, and regulations, and all terms, precautions, practices, policies and guidelines IKAN has made and may make available.

IKAN accepts no liability for damage, injury or any legal responsibility incurred directly or indirectly from the use of this product. The user shall observe safe and lawful practices including, but not limited to, those set forth in this document.

*This means that as long as a distance of at least 5 in. from the transmitting antenna is maintained, it is not possible to exceed the MPE limits set forth by the FCC.

Learn More

More dynamic information at official website: www.ikancorp.com

Support

Contact email: support@ikancorp.com

CONDITIONS OF WARRANTY SERVICE

- Free service for one year from the day of purchase if the problem is caused by manufacturing errors.
- The components and maintenance service free will be charged if the warranty period is expired.

Free Service will not be Provided in the Following Situations:(*Even if the product is still within the warranty period.)

- Damage caused by abuse or misuse, dismantling, or changes to the product not made by the company.
- Damage caused by natural disaster, abnormal voltage, and environmental factors, etc.